

# Chip Inductor (Chip Coil) Power Inductor (Wire Wound Type)

## LQH32P\_N0 Series (1210 Size)

### ■ Dimensions

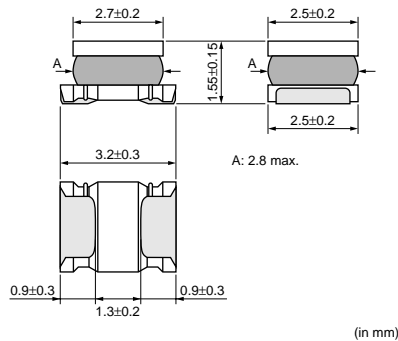

### ■ Packaging

Code	Packaging	Minimum Quantity
L	180mm Embossed Tape	2000
K	330mm Embossed Tape	7500

### ■ Rated Value (□: packaging code)

Part Number	Inductance	Rated Current (Based on Inductance Change)	Rated Current (Based on Temperature Rise)	DC Resistance	Self Resonance Frequency (min.)
LQH32PNR47NN0□	0.47μH±30%	3400mA	2550mA	0.03ohm ±20%	100MHz
LQH32PN1R0NN0□	1.0μH±30%	2300mA	2050mA	0.045ohm ±20%	100MHz
LQH32PN1R5NN0□	1.5μH±30%	1750mA	1750mA	0.057ohm ±20%	70MHz
LQH32PN2R2NN0□	2.2μH±30%	1550mA	1600mA	0.076ohm ±20%	70MHz
LQH32PN3R3NN0□	3.3μH±30%	1250mA	1200mA	0.12ohm ±20%	50MHz
LQH32PN4R7NN0□	4.7μH±30%	1000mA	1000mA	0.18ohm ±20%	40MHz
LQH32PN6R8NN0□	6.8μH±30%	850mA	850mA	0.24ohm ±20%	40MHz
LQH32PN100MN0□	10μH±20%	750mA	700mA	0.38ohm ±20%	30MHz
LQH32PN150MN0□	15μH±20%	600mA	520mA	0.57ohm ±20%	20MHz
LQH32PN220MN0□	22μH±20%	500mA	450mA	0.81ohm ±20%	20MHz
LQH32PN330MN0□	33μH±20%	380mA	390mA	1.15ohm ±20%	13MHz
LQH32PN470MN0□	47μH±20%	330mA	310mA	1.78ohm ±20%	11MHz
LQH32PN680MN0□	68μH±20%	280mA	275mA	2.28ohm ±20%	11MHz
LQH32PN101MN0□	100μH±20%	180mA	250mA	2.70ohm ±20%	8MHz
LQH32PN121MN0□	120μH±20%	170mA	200mA	4.38ohm ±20%	8MHz

Test Frequency: 1MHz Class of Magnetic Shield: Magnetic shield of magnetic powder in resin

Operating Temperature Range (Self-temperature rise is included): -40 to +125°C

Operating Temperature Range (Self-temperature rise is not included): -40 to +85°C

Only for reflow soldering.

\*1 When Rated Current is applied to the Products, Inductance will be within ±30% of nominal Inductance value.

\*2 When Rated Current is applied to the Products, self-generation of heat will rise to 40°C or less.

Continued on the following page.

● This data sheet is applied for CHIP INDUCTORS (CHIP COILS) used for General Electronics equipment for your design.

### ⚠ Note:

- This datasheet is downloaded from the website of Murata Manufacturing co., Ltd. Therefore, it's specifications are subject to change or our products in it may be discontinued without advance notice. Please check with our sales representatives or product engineers before ordering.
- This datasheet has only typical specifications because there is no space for detailed specifications. Therefore, please approve our product specifications or transact the approval sheet for product specifications before ordering.

 Continued from the preceding page.

### ■ Notice (Rated Current)

<Rated Current>

(Based on Inductance Change)

When Rated Current is applied to the Products,  
Inductance will be within +30% of nominal  
Inductance value.

<Rated Current>

(Based on Temperature Rise)

When Rated Current is applied to the Products,  
self-generation of heat will rise to 40°C or less.

### ■ Inductance-Frequency Characteristics (Typ.)

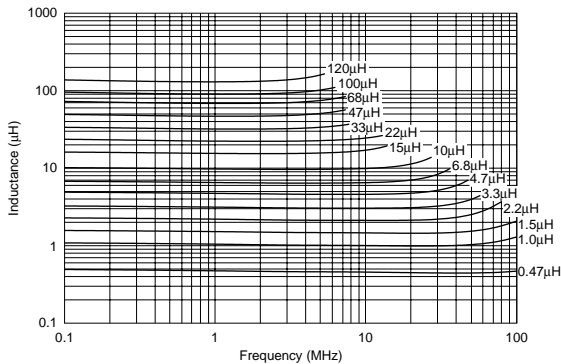

### ■ Inductance-Current Characteristics (Typ.)

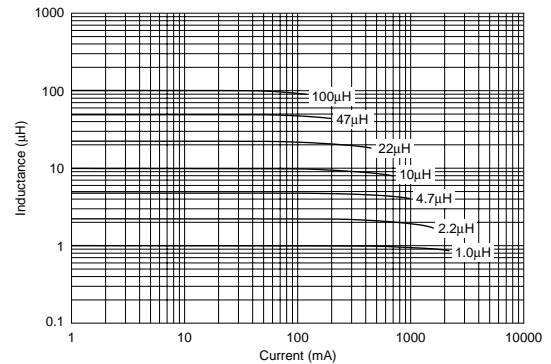

### ■ Temperature Rise Characteristics (Typ.)

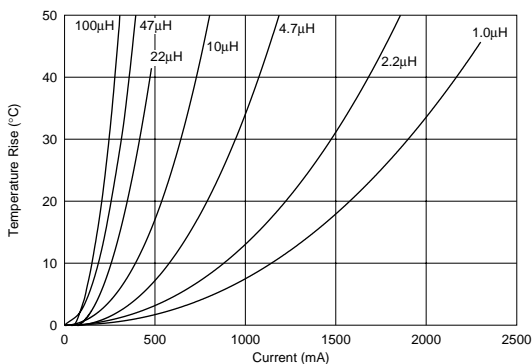

### ■ ⚠ Caution/Notice

#### ⚠ Caution (Rating)

Do not use products beyond the rated current as this may create excessive heat.

#### Notice

Solderability of Tin plating termination chip might be deteriorated when low temperature soldering profile where peak solder temperature is below the Tin melting point is used. Please confirm the solderability of Tin plating termination chip before use.

● This data sheet is applied for CHIP INDUCTORS (CHIP COILS) used for General Electronics equipment for your design.

#### ⚠ Note:

1. This datasheet is downloaded from the website of Murata Manufacturing co., Ltd. Therefore, it's specifications are subject to change or our products in it may be discontinued without advance notice. Please check with our sales representatives or product engineers before ordering.
2. This datasheet has only typical specifications because there is no space for detailed specifications. Therefore, please approve our product specifications or transact the approval sheet for product specifications before ordering.