

### Features

- ✧ UL Recognized File # E-326854
- ✧ Plastic material used carriers Underwriters Laboratory Classification 94V-0
- ✧ Metal silicon junction, majority carrier conduction
- ✧ Low power loss, high efficiency
- ✧ High current capability, low forward voltage drop
- ✧ High surge capability
- ✧ For use in power supply - output rectification, power management, instrumentation
- ✧ Guard-ring for overvoltage protection
- ✧ High temperature soldering guaranteed: 260°C/10 seconds
- ✧ Green compound with suffix "G" on packing code & prefix "G" on datecode



### Mechanical Data

- ✧ Case: D<sup>2</sup>PAK molded plastic body
- ✧ Terminals: Pure tin plated, lead free, solderable per MIL-STD-750, Method 2026
- ✧ Polarity: As marked
- ✧ Mounting position: Any
- ✧ Mounting torque: 5 in. - lbs, max
- ✧ Weight: 1.41 grams

### Ordering Information

Part No.	Package	Packing	Packing code	Green Compound Packing code
MBRS20HxxCT	D2PAK	800 / 13" REEL	RN	RNG

Note: "x" is Device Code from "100" thru "200".

### Maximum Ratings and Electrical Characteristics

Rating at 25 °C ambient temperature unless otherwise specified.

Single phase, half wave, 60 Hz, resistive or inductive load.

For capacitive load, derate current by 20%

Type Number	Symbol	MBRS 20H100CT	MBRS 20H150CT	MBRS 20H200CT	Unit
Maximum Repetitive Peak Reverse Voltage	$V_{RRM}$	100	150	200	V
Maximum RMS Voltage	$V_{RMS}$	70	105	140	V
Maximum DC Blocking Voltage	$V_{DC}$	100	150	200	V
Maximum Average Forward Rectified Current	$I_{F(AV)}$	20			A
Peak Repetitive Surge Current (Rated $V_R$ , Square Wave, 20KHz)	$I_{FRM}$	20			A
Peak Forward Surge Current, 8.3 ms Single Half Sine-wave Superimposed on Rated Load (JEDEC method)	$I_{FSM}$	150			A
Peak Repetitive Reverse Surge Current (Note 1)	$I_{RRM}$	1		0.5	A
Maximum Instantaneous Forward Voltage (Note 2) $I_F=10A, T_A=25^\circ C$ $I_F=10A, T_A=125^\circ C$ $I_F=20A, T_A=25^\circ C$ $I_F=20A, T_A=125^\circ C$	$V_F$	0.85 0.75 0.95 0.85	0.88 0.75 0.97 0.85		V
Maximum Reverse Current @ Rated $V_R$ $T_A=25^\circ C$ $T_A=125^\circ C$	$I_R$	5			uA
		2			mA
Voltage Rate of Change, (Rated $V_R$ )	$dV/dt$	10000			V/us
Typical Thermal Resistance (Note 3)	$R_{\theta JC}$	1.5			°C/W
Operating Temperature Range	$T_J$	- 65 to + 175			°C
Storage Temperature Range	$T_{STG}$	- 65 to + 175			°C

Note 1: 2.0uS Pulse Width, f=1.0KHz

Note 2: Pulse Test : 300uS Pulse Width, 1% Duty Cycle

RATINGS AND CHARACTERISTIC CURVES (MBRS20H100CT THRU MBRS20H200CT)

FIG. 1 FORWARD CURRENT DERATING CURVE

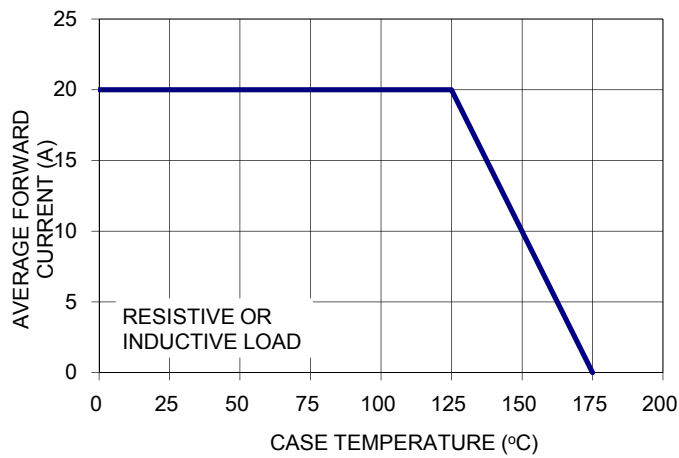

FIG. 2 MAXIMUM NON-REPETITIVE FORWARD SURGE CURRENT PER LEG

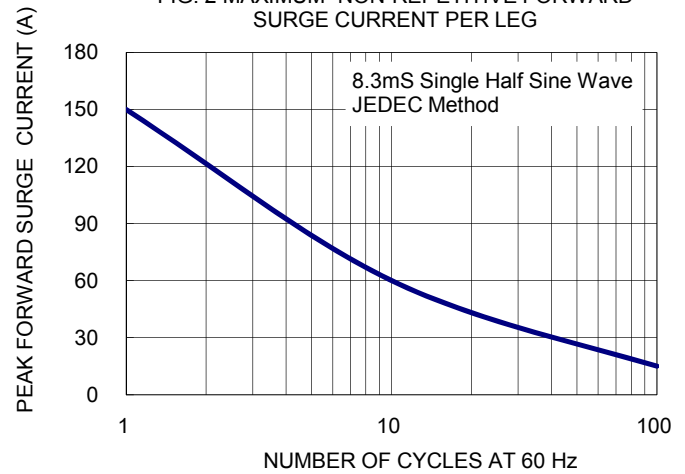

FIG. 3 TYPICAL FORWARD CHARACTERISTICS PER LEG

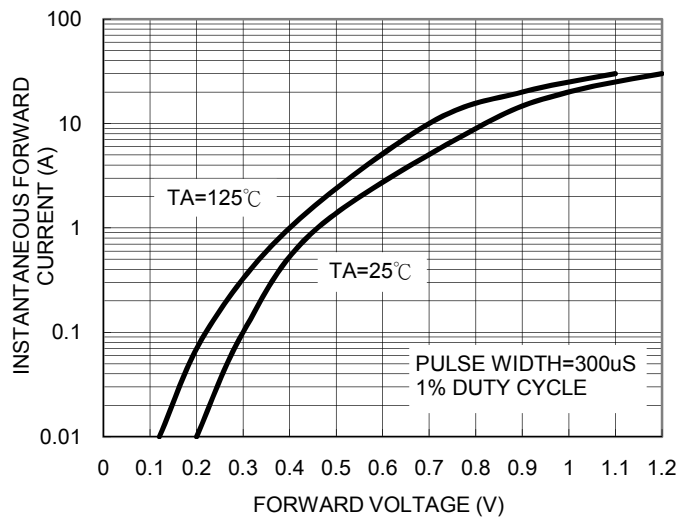

FIG. 4 TYPICAL REVERSE CHARACTERISTICS PER LEG

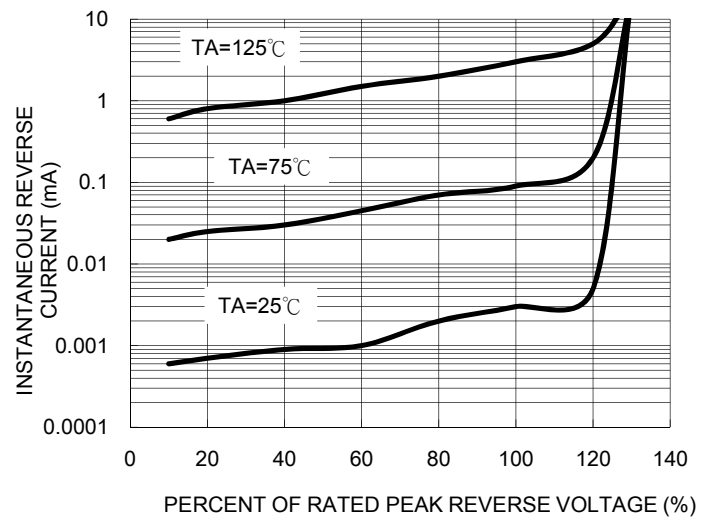

FIG. 5 TYPICAL JUNCTION CAPACITANCE

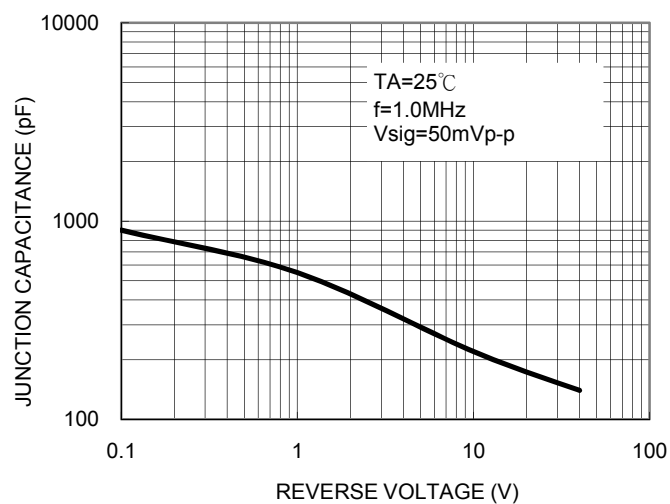
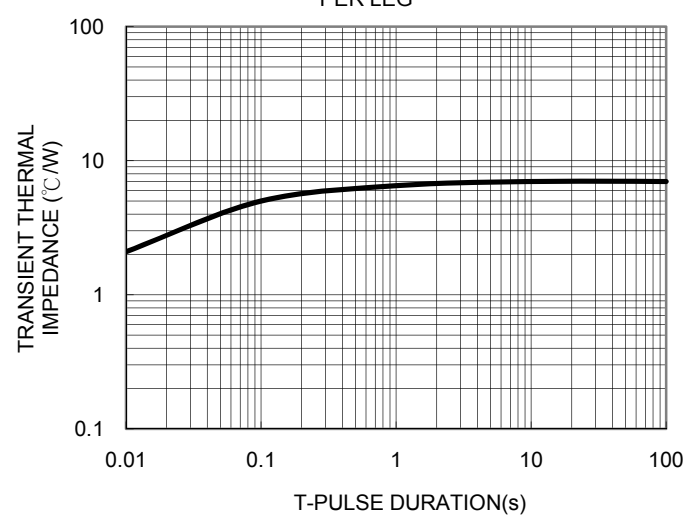
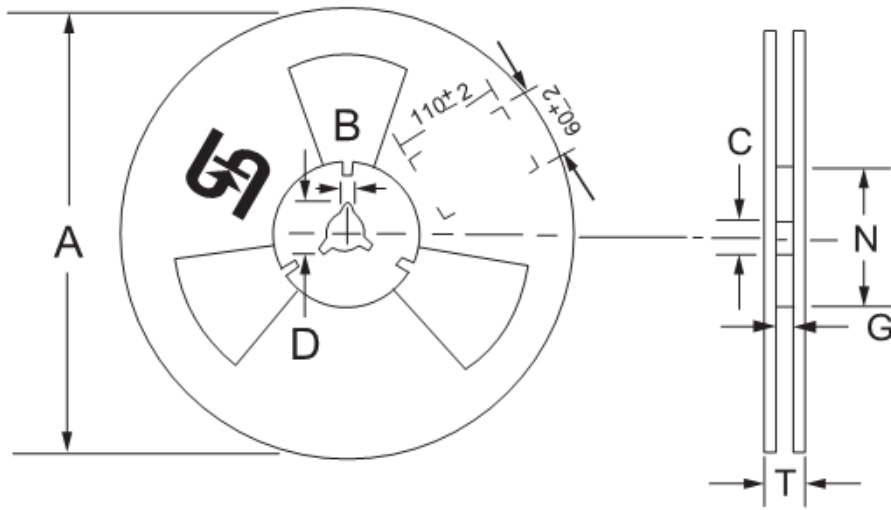
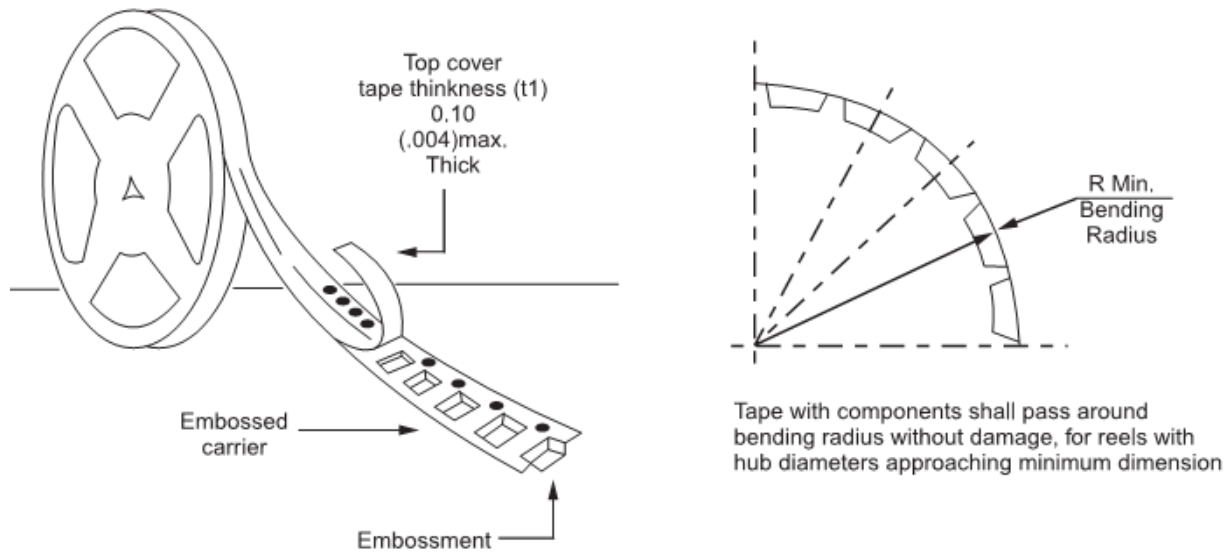

FIG. 6 TYPICAL TRANSIENT THERMAL IMPEDANCE PER LEG



**Tape & Reel specification**



Reel Size	Tape Size	A	B	C	D	N	G	T
		max	±0.5	±0.5	min	±0.5	+2.0;-0	max
13"	24mm	330	2	13	20.2	75	24.4	30.4

Unit (mm)

**Suggested PAD Layout**

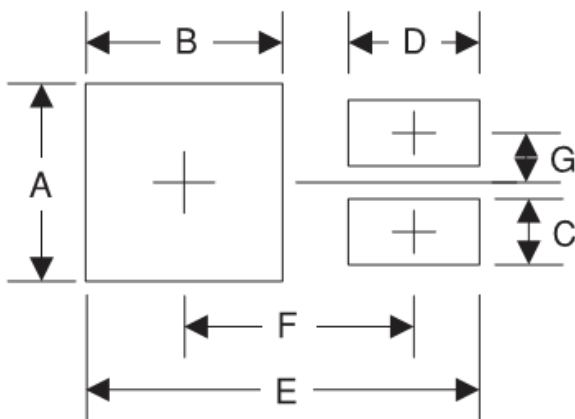

Symbol	Unit(mm)
A	10.8
B	7
C	1.1
D	3.5
E	16.9
F	9.5
G	2.5

**Dimensions**

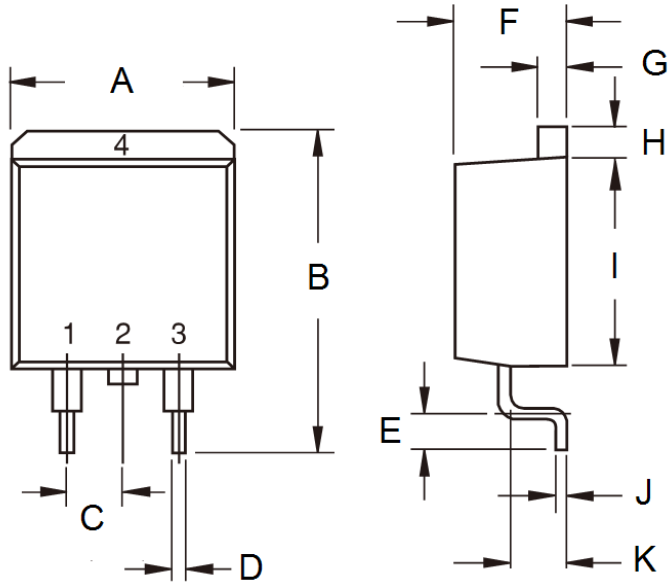

DIM.	Unit(mm)		Unit(inch)	
	Min	Max	Min	Max
A	-	10.5	-	0.413
B	14.60	15.88	0.575	0.625
C	2.41	2.67	0.095	0.105
D	0.68	0.94	0.027	0.037
E	2.29	2.79	0.090	0.110
F	4.44	4.70	0.175	0.185
G	1.14	1.40	0.045	0.055
H	1.14	1.40	0.045	0.055
I	8.25	9.25	0.325	0.364
J	0.36	0.53	0.014	0.021
K	2.03	2.79	0.080	0.110

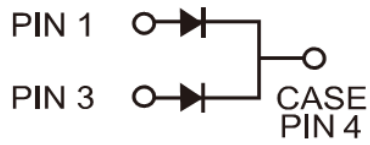

**Marking Diagram**



P/N = Specific Device Code  
G = Green Compound  
YWW = Date Code