

# Chip Resistor Networks

## MNR Series < Automotive >

### ●Features

- 1) Can be mounted even more densely than chip resistors.
- 2) Mounting cost can be reduced by less frequency of mounting times.
- 3) Convex electrodes secures visual inspection of fillets after soldering.
- 4) ROHM resistors have obtained ISO9001 / ISO / TS16949 certification.
- 5) "Automotive" product is AEC-Q200 compliant.

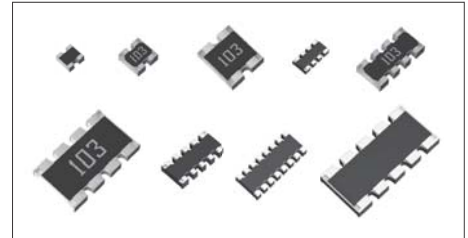

Part No.	Size		No. of terminals	No. of elements	Type Code		Packing Specification	Quantity / Reel
	(mm)	(inch)			GENERAL PURPOSE	AUTOMOTIVE *Corresponds to AEC-Q200		
<b>MNR02</b>	1005 × 2	0402 × 2	4	2	MRAP	M0AP	Paper tape (2mm Pitch)	10,000
<b>MNR04</b>	1005 × 4	0402 × 4	8	4	MRAP	M0AP		
<b>MNR12</b>	1608 × 2	0603 × 2	4	2	ERAP	E0AP	Paper tape (4mm Pitch)	5,000
<b>MNR14</b>	1608 × 4	0603 × 4	8	4	ERAP	E0AP		
<b>MNR15</b>	1608 × 5	0603 × 5	10	8	ERRP	E0RP		
<b>MNR18</b>	1605 × 8	0602 × 8	16	8	ERAP	E0AP		
<b>MNR32</b>	3216 × 2	1206 × 2	4	2	J0AB		Embossed tape (4mm Pitch)	4,000
<b>MNR34</b>	3216 × 4	1206 × 4	8	4	J5AB			
<b>MNR35</b>	3216 × 5	1206 × 5	10	8	J5R			

\*Please contact us for status of AEC-Q200 on "General purpose" products.

### ●Part Number Description

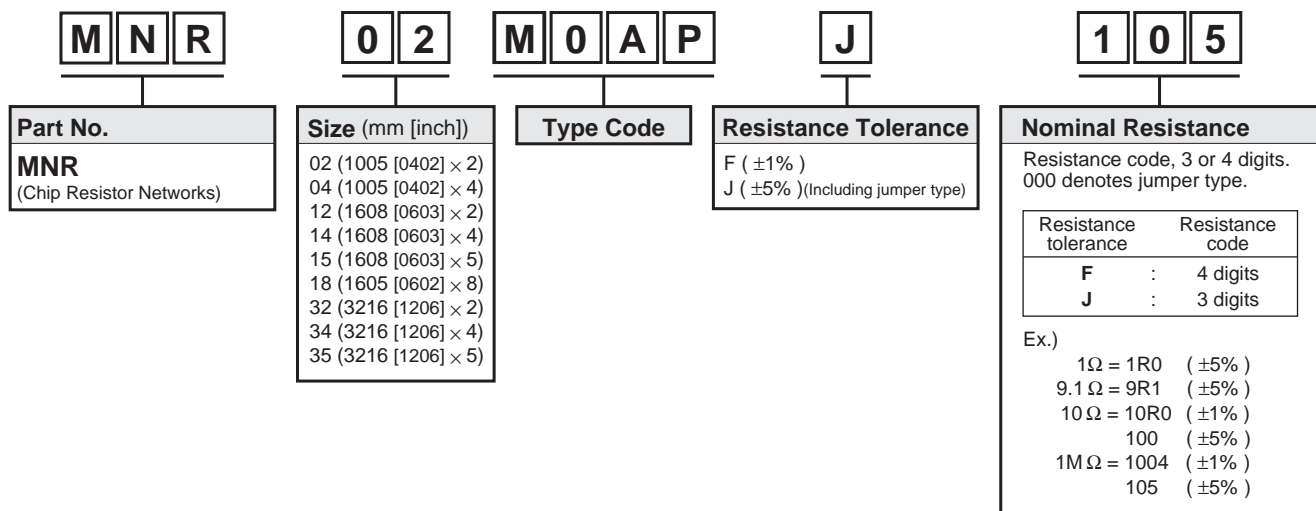

●Products List

Part No.	Type Code	Rated Power (70°C) (W)	Limiting Element Voltage (V)	Maximum Overload Voltage (V)	Temperature Coefficient (ppm / °C)	Resistance Tolerance (%)	Resistance Range	Series	Operating Temperature Range (°C)
MNR02	M0AP	0.063 / Element	25	-	±200	J(±5%)	10Ω to 1MΩ	E24	-55 to +155
MNR04	M0AP	0.063 / Element	25	50	+500/-250	J(±5%)	1Ω to 9.1Ω	E24	
					±200		10Ω to 1MΩ		
Jumper type : Rmax = 50mΩ / Imax. = 1A (Element)									
MNR12	E0AP	0.063 / Element	50	-	±200	J(±5%)	10Ω to 1MΩ	E24	
					±100	F(±1%)	10Ω to 1MΩ		
Jumper type : Rmax = 50mΩ / Imax. = 1A (Element)									
MNR14	E0AP	0.063 / Element	50	-	±500	J(±5%)	2.2Ω to 6.8Ω	E6	
					±200		10Ω to 1MΩ	E24	
					±100	F(±1%)	10Ω to 1MΩ		
Jumper type : Rmax = 50mΩ / Imax. = 1A (Element)									
MNR15	E0RP	0.031 / Element	12.5	-	±200	J(±5%)	56Ω to 100kΩ	E24	
MNR18	E0AP	0.063 / Element	25	-	±200	J(±5%)	10Ω to 1MΩ	E24	
									Jumper type : Rmax = 50mΩ / Imax. = 1A (Element)
MNR32	J0AB	0.125 / Element	200	400	±200	J(±5%)	10Ω to 1MΩ	E24	-55 to +125
MNR34	J5AB	0.125 / Element	200	400	±200	J(±5%)	10Ω to 1MΩ	E24	
MNR35	J5R	0.063 / Element	50	100	±200	J(±5%)	56Ω to 100kΩ	E12	

\*Design and specifications are subject to change without notice. Carefully check the specification sheet supplied with the product before using or ordering it.

●Circuit Construction

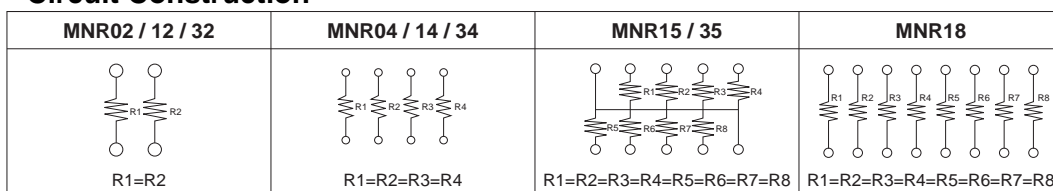

●Chip Resistor Dimensions and Markings

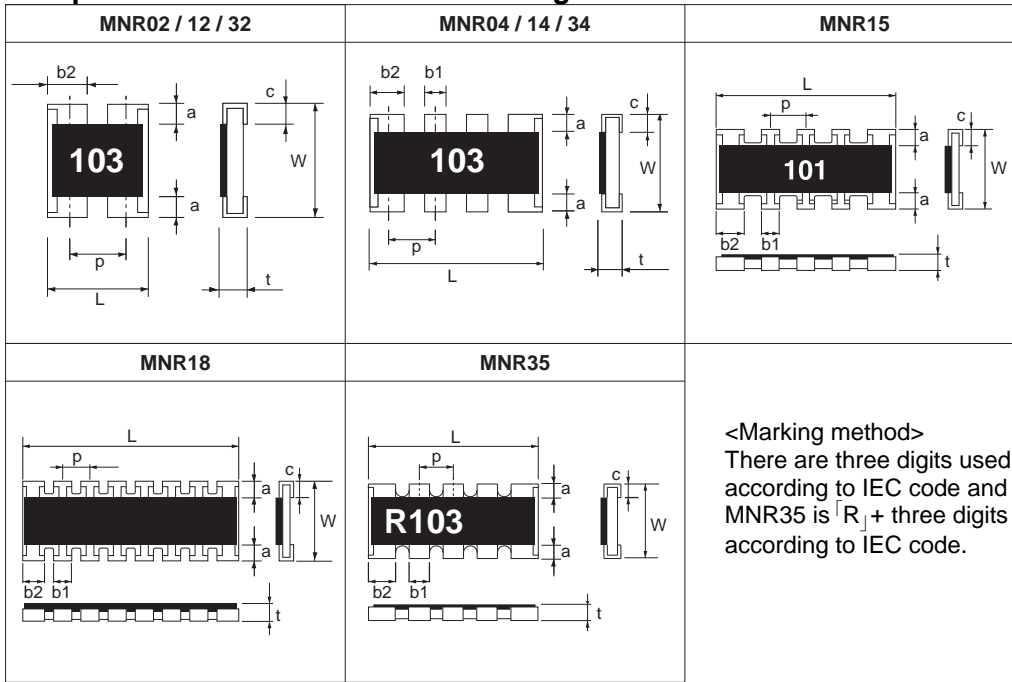

<Marking method>  
 There are three digits used for the calculation number according to IEC code and "R" is used for the decimal point. MNR35 is "R" + three digits used for the calculation number according to IEC code.

(Unit : mm)

Part No.	Type Code	(mm)	(inch)	L	W	t	a	b1	b2	c	p	Marking existence *Including jumper type
MNR02	M0AP	1005 × 2	0402 × 2	1.0±0.1	1.0±0.1	0.35±0.1	0.2±0.1	—	0.33 <sup>+0.1</sup> <sub>0</sub>	0.25±0.1	0.68	No
MNR04	M0AP	1005 × 4	0402 × 4	2.0±0.2	1.0±0.1	0.35±0.1	0.2±0.1	0.3±0.1	0.4±0.1	0.25±0.1	0.5	No
MNR12	E0AP	1608 × 2	0603 × 2	1.6±0.1	1.6±0.1	0.5±0.1	0.3±0.2	—	0.6±0.15	0.25±0.15	0.8	Yes
MNR14	E0AP	1608 × 4	0603 × 4	3.2±0.1	1.6±0.1	0.5±0.1	0.3±0.2	0.4±0.15	0.6±0.15	0.25±0.15	0.8	Yes
MNR15	E0AP	1608 × 5	0603 × 5	3.2±0.1	1.6±0.1	0.5±0.1	0.3±0.1	0.32±0.15	0.48±0.15	0.3±0.1	0.64	Yes
MNR18	J5AB	1605 × 8	0602 × 8	3.8±0.1	1.6±0.1	0.45±0.1	0.3±0.2	0.3±0.1	0.3±0.1	0.3±0.2	0.5	No
MNR32	E0RP	3216 × 2	1206 × 2	2.6±0.2	3.1±0.2	0.55±0.1	0.5±0.3	—	1.0±0.2	0.5Max	1.27	Yes
MNR34	E0AP	3216 × 4	1206 × 4	5.2±0.4	3.1±0.2	0.55±0.1	0.5±0.3	0.8±0.2	1.0±0.2	0.5Max	1.27	Yes
MNR35	J5R	3216 × 5	1206 × 5	6.4±0.4	3.1±0.2	0.55±0.1	0.5±0.3	0.8±0.2	1.0±0.2	0.5Max	1.27	Yes

●Land pattern Example

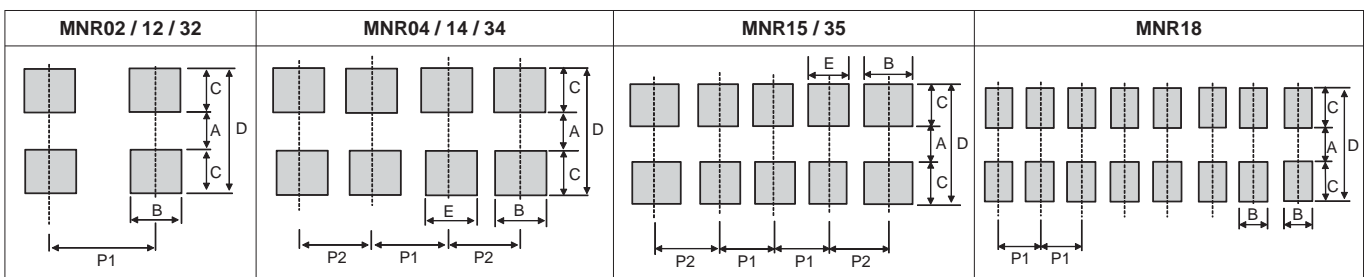
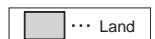

(Unit : mm)

Part No.	Dimensions Type Code	A	B	C	D	E	P1	P2
MNR02	M0AP	0.5	0.35 to 0.4	0.5	1.5	—	0.65 to 0.7	—
MNR04	M0AP	0.5	0.4	0.5	1.5	0.3	0.5	0.5 to 0.55
MNR12	E0AP	1.0	0.4 to 0.6	0.7 to 0.8	2.4 to 2.6	—	0.8 to 1.0	—
MNR14	E0AP	1.0	0.4 to 0.6	0.7 to 0.8	2.4 to 2.6	0.4	0.8	0.8 to 0.9
MNR15	E0RP	1.0	0.48	0.7 to 0.8	2.4 to 2.6	0.32	0.64	0.72
MNR18	E0AP	1.0	0.3	0.7 to 0.8	2.4 to 2.6	—	0.5	—
MNR32	J0AB	2.1	0.8 to 1.0	0.8 to 1.0	3.7 to 4.1	—	1.27 to 1.6	—
MNR34	J5AB	2.1	0.8 to 1.0	0.8 to 1.0	3.7 to 4.1	0.7 to 0.8	1.27 to 1.35	1.27 to 1.45
MNR35	J5R	2.1	0.8 to 1.0	0.8 to 1.0	3.7 to 4.1	0.7 to 0.8	1.27 to 1.3	1.27 to 1.4

●Derating Curve

When the ambient temperature exceeds 70°C, power dissipation must be adjusted according to the derating curves below.

■ MNR02 / 04 / 12 / 14

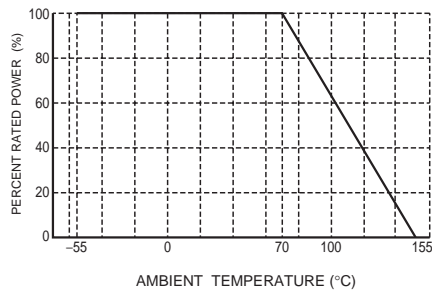

■ MNR15 / 18 / 32 / 34 / 35

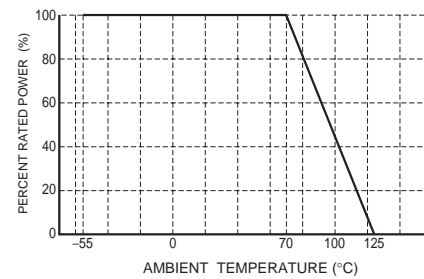

●Characteristics

Test Items	Guaranteed Value		Test Conditions
	Resistor Type	Jumper Type	
Resistance	See "Products List"		20°C
Variation of resistance with temperature	See "Products List"		Measurement : +20 / -55 / +20 / +125°C
Overload	± (2.0%+0.1Ω)	Max. 50mΩ	Rated voltage (current) ×2.5, 2s. Maximum overload voltage
Solderability	A new uniform coating of minimum of 95% of the surface being immersed and no soldering damage.		Rosin-Ethanol : 25% (weight) Soldering condition : 235±5°C Duration of immersion : 2.0±0.5s
Resistance to soldering heat	± (1.0%+0.05Ω) ± (1.0%+0.1Ω)※MNR35  No remarkable abnormality on the appearance.	Max. 50mΩ	Soldering condition : 260±5°C Duration of immersion : 10±1s
Rapid change of temperature	± (1.0%+0.05Ω) ± (1.0%+0.1Ω)※MNR35	Max. 50mΩ	Test temp. : -55°C to +125°C 5cycle
Damp heat, steady state	± (3.0%+0.1Ω)	Max. 100mΩ	40°C, 93%RH (Relative Humidity) Test time : 1,000h to 1,048h
Endurance at 70°C	± (3.0%+0.1Ω)	Max. 100mΩ	70°C Rated voltage (current) 1.5h : ON – 0.5h : OFF Test time : 1,000h to 1,048h
Endurance	± (3.0%+0.1Ω)	Max. 100mΩ	125°C (MNR15 / 18 / 32 / 34 / 35) 155°C (MNR02 / 04 / 12 / 14) Test time : 1,000h to 1,048h
Resistance to solvent	± (1.0%+0.05Ω) ± (1.0%+0.1Ω)※MNR35	Max. 50mΩ	23±5°C, Immersion cleaning, 5±0.5min Solvent : 2-propanol
Bend strength of the end face plating	± (1.0%+0.05Ω)  Without mechanical damage such as breaks.	Max. 50mΩ	—

Compliance Standard(s) : IEC60115-8  
JISC 5201-8

●Chip weight (typical value)

Parameter	Unit	MNR02 M0AP	MNR04 M0AP	MNR12 E0AP	MNR14 E0AP	MNR15 E0RP	MNR18 E0AP	MNR32 J0AB	MNR34 J5AB	MNR35 J5R
Weight	mg/pc	1.04	2.22	4.04	7.55	7.41	8.90	15.9	31.2	38.4

●Tape Dimensions

(Unit : mm)

■ Paper Tape

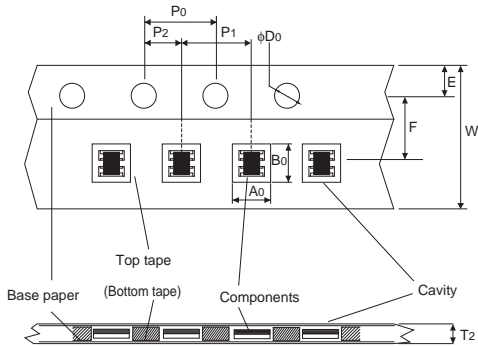

Part No.	Type Code	W	F	E	A0	B0
MNR02	M0AP	8.0±0.3	3.5±0.05	1.75±0.1	1.17±0.1	1.17±0.1
MNR04	M0AP	8.0±0.3	3.5±0.05	1.75±0.1	1.2±0.1	2.2±0.1
MNR12	E0AP	8.0±0.3	3.5±0.05	1.75±0.1	1.8±0.1	1.8±0.1
MNR14	E0AP	8.0±0.3	3.5±0.05	1.75±0.1	1.8±0.1	3.4±0.1
MNR15	E0RP	8.0±0.3	3.5±0.05	1.75±0.1	1.8±0.1	3.4±0.1
MNR18	E0AP	8.0±0.3	3.5±0.05	1.75±0.1	1.95±0.15	4.1±0.15

Part No.	Type Code	D0	P0	P1	P2	T2
MNR02	M0AP	φ1.5 <sup>+0.1</sup> / <sub>0</sub>	4.0±0.1	2.0±0.1	2.0±0.05	Max 0.5
MNR04	M0AP	φ1.5 <sup>+0.1</sup> / <sub>0</sub>	4.0±0.1	2.0±0.1	2.0±0.05	Max 1.1
MNR12	E0AP	φ1.5 <sup>+0.1</sup> / <sub>0</sub>	4.0±0.1	4.0±0.1	2.0±0.05	Max 1.1
MNR14	E0AP	φ1.5 <sup>+0.1</sup> / <sub>0</sub>	4.0±0.1	4.0±0.1	2.0±0.05	Max 1.1
MNR15	E0RP	φ1.5 <sup>+0.1</sup> / <sub>0</sub>	4.0±0.1	4.0±0.1	2.0±0.05	Max 1.1
MNR18	E0AP	φ1.5 <sup>+0.1</sup> / <sub>0</sub>	4.0±0.1	4.0±0.1	2.0±0.05	Max 1.1

■ Embossed Tape

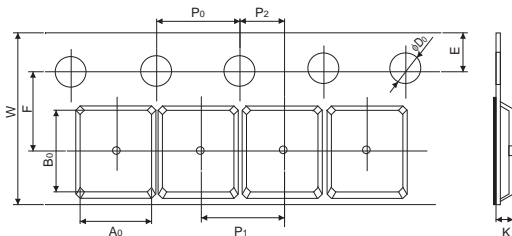

(Unit : mm)

Part No.	Type Code	W	F	E	A0	B0
MNR32	J0AB	8.0±0.3	3.5±0.05	1.75±0.1	3.0±0.1	3.5±0.1
MNR34	J5AB	12.0±0.3	5.5±0.05	1.75±0.1	3.4±0.1	5.6±0.1
MNR35	J5R	12.0±0.3	5.5±0.05	1.75±0.1	3.4±0.1	6.6±0.1

Part No.	Type Code	D0	P0	P1	P2	K
MNR32	J0AB	φ1.5 <sup>+0.1</sup> / <sub>0</sub>	4.0±0.1	4.0±0.1	2.0±0.05	0.9±0.1
MNR34	J5AB	φ1.5 <sup>+0.1</sup> / <sub>0</sub>	4.0±0.1	4.0±0.1	2.0±0.05	1.0±0.15
MNR35	J5R	φ1.5 <sup>+0.1</sup> / <sub>0</sub>	4.0±0.1	4.0±0.1	2.0±0.05	1.0±0.15

●Reel Dimensions

Using two kinds of reels for taping. (\*MNR34/35 applies Fig. 1 only.)

■ Fig.1

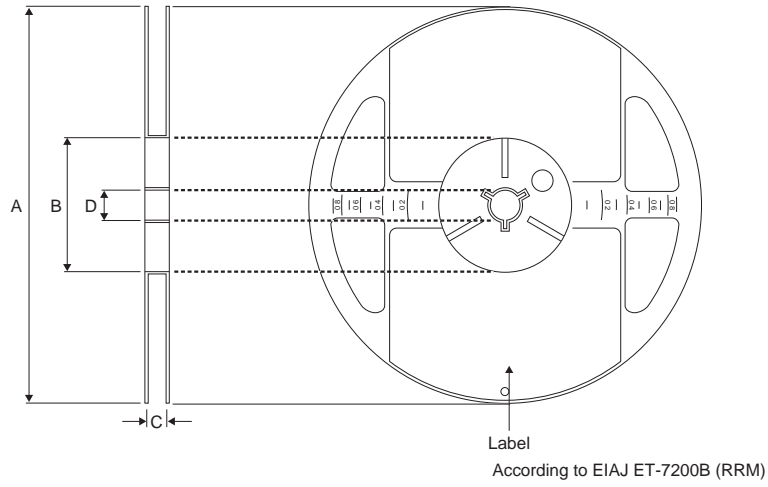

■ Fig.2

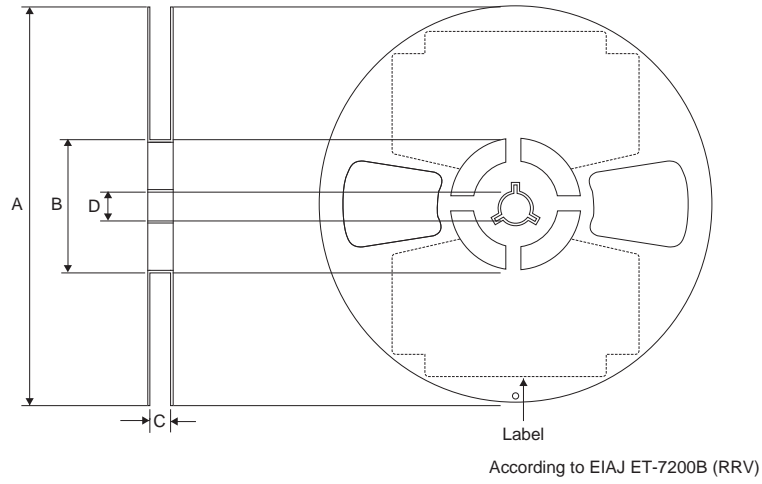

(Unit : mm)

Part No.	Type Code	A	B	C	D
MNR02	M0AP	φ180 <sup>0</sup> <sub>-1.5</sub>	φ60 <sup>+1.0</sup> <sub>0</sub>	9 <sup>+1.0</sup> <sub>0</sub>	φ13±0.2
MNR04	M0AP				
MNR12	E0AP				
MNR14	E0AP				
MNR15	E0RP				
MNR18	E0AP				
MNR32	J0AB				
MNR34	J5AB			13 <sup>+1.0</sup> <sub>0</sub>	
MNR35	J5R				

## Notes

No copying or reproduction of this document, in part or in whole, is permitted without the consent of ROHM Co.,Ltd.

The content specified herein is subject to change for improvement without notice.

The content specified herein is for the purpose of introducing ROHM's products (hereinafter "Products"). If you wish to use any such Product, please be sure to refer to the specifications, which can be obtained from ROHM upon request.

Examples of application circuits, circuit constants and any other information contained herein illustrate the standard usage and operations of the Products. The peripheral conditions must be taken into account when designing circuits for mass production.

Great care was taken in ensuring the accuracy of the information specified in this document. However, should you incur any damage arising from any inaccuracy or misprint of such information, ROHM shall bear no responsibility for such damage.

The technical information specified herein is intended only to show the typical functions of and examples of application circuits for the Products. ROHM does not grant you, explicitly or implicitly, any license to use or exercise intellectual property or other rights held by ROHM and other parties. ROHM shall bear no responsibility whatsoever for any dispute arising from the use of such technical information.

The Products specified in this document are intended to be used with general-use electronic equipment or devices (such as audio visual equipment, office-automation equipment, communication devices, electronic appliances and amusement devices).

The Products specified in this document are not designed to be radiation tolerant.

While ROHM always makes efforts to enhance the quality and reliability of its Products, a Product may fail or malfunction for a variety of reasons.

Please be sure to implement in your equipment using the Products safety measures to guard against the possibility of physical injury, fire or any other damage caused in the event of the failure of any Product, such as derating, redundancy, fire control and fail-safe designs. ROHM shall bear no responsibility whatsoever for your use of any Product outside of the prescribed scope or not in accordance with the instruction manual.

The Products are not designed or manufactured to be used with any equipment, device or system which requires an extremely high level of reliability the failure or malfunction of which may result in a direct threat to human life or create a risk of human injury (such as a medical instrument, transportation equipment, aerospace machinery, nuclear-reactor controller, fuel-controller or other safety device). ROHM shall bear no responsibility in any way for use of any of the Products for the above special purposes. If a Product is intended to be used for any such special purpose, please contact a ROHM sales representative before purchasing.

If you intend to export or ship overseas any Product or technology specified herein that may be controlled under the Foreign Exchange and the Foreign Trade Law, you will be required to obtain a license or permit under the Law.



Thank you for your accessing to ROHM product informations.  
More detail product informations and catalogs are available, please contact us.

**ROHM Customer Support System**

<http://www.rohm.com/contact/>