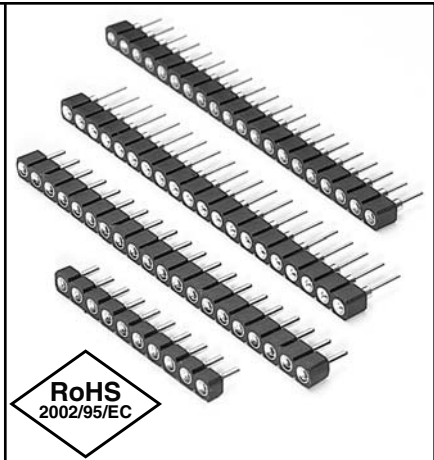

Fig. 1

- SIP sockets accept .015 - .025" diameter pins and standard IC leads.
- Various solder tails available: standard length, long for multi-layer boards, very low and ultra low profile. See Mill-Max #1001, 0134, 0501 or 1534 pins (See pages 132, 133, 136) for details.
- Hi-Rel, 4-finger BeCu #12 & #30 contacts are rated at 3 amps. See pages 218 for details.
- Insulators are high temp. thermoplastic.



Ordering Information

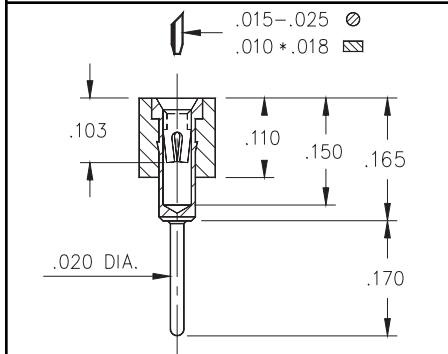

Fig. 2

Fig. 1

Series 310...001 Standard Solder Tail

310-XX-1__-41-001000

Specify # of pins → 01-64

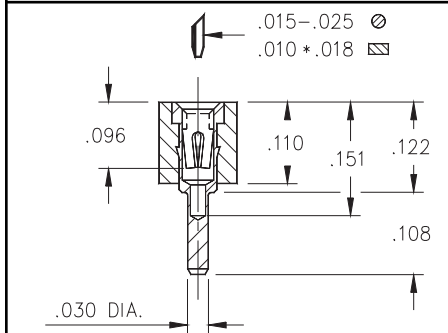

Fig. 3

Fig. 2

Series 311...001 Long Solder Tail

★ 41 & 91 Platings Non-Standard 311-XX-1__-41-001000

Specify # of pins → 01-64

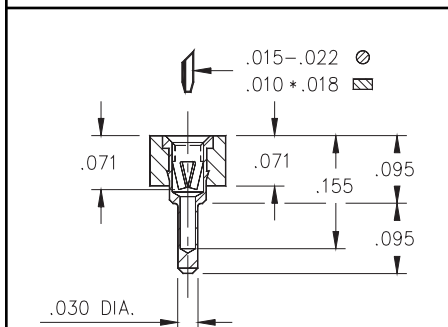

Fig. 4

Fig. 3

Series 315...001 Very Low Profile

★ 41 & 91 Platings Non-Standard 315-XX-1__-41-001000

Specify # of pins → 01-64

Series 315...003 Ultra Low Profile

★ 41 & 91 Platings Non-Standard 315-XX-1__-41-003000

Specify # of pins → 01-64

For Electrical, Mechanical & Environmental Data, See pg. 4

XX=Plating Code See Below

For RoHS compliance select ◇ plating code.

SPECIFY PLATING CODE XX=	13◇	91	93	99	41◇	43◇	44◇
Sleeve (Pin)	10μ" Au	200μ" Sn/Pb	200μ" Sn/Pb	200μ" Sn/Pb	200μ" Sn	200μ" Sn	200μ" Sn
Contact (Clip)	30μ" Au	10μ" Au	30μ" Au	200μ" Sn/Pb	10μ" Au	30μ" Au	200μ" Sn