

## F100163 Dual 8-Input Multiplexer

### General Description

The F100163 is a dual 8-input multiplexer. The Data Select ( $S_n$ ) inputs determine which bit ( $A_n$  and  $B_n$ ) will be presented at the outputs ( $Z_a$  and  $Z_b$  respectively). The same bit (0-7) will be selected for both the  $Z_a$  and  $Z_b$  output. All inputs have 50 k $\Omega$  pull-down resistors.

Refer to the F100363 datasheet for:

- PCC packaging
- Lower power
- Military versions
- Extended voltage specs (-4.2V to -5.7V)

**Ordering Code:** See Section 8

### Logic Symbol

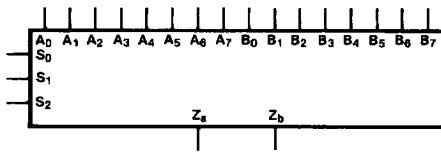

TL/F/9864-3

Pin Names	Description
$S_0$ - $S_2$	Data Select Inputs
$A_0$ - $A_7$	A Data Inputs
$B_0$ - $B_7$	B Data Inputs
$Z_a$ , $Z_b$	Data Outputs

### Connection Diagrams

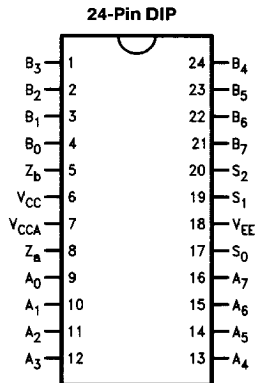

TL/F/9864-1

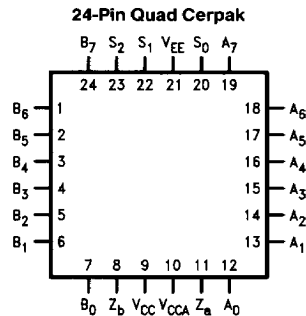

TL/F/9864-2

## Logic Diagram

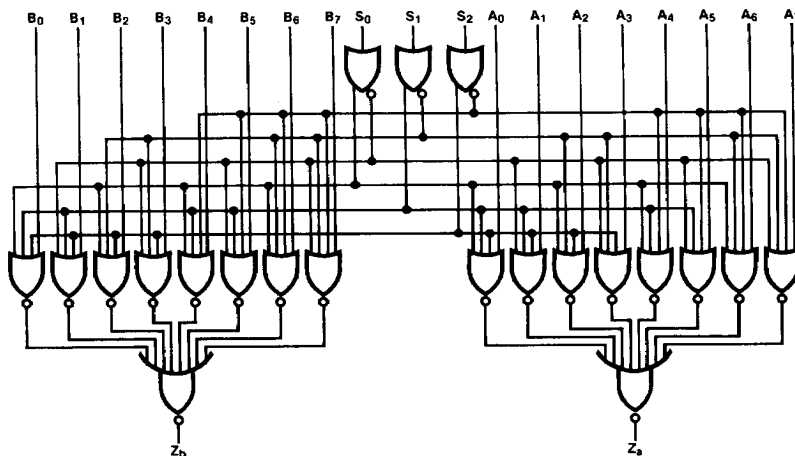

TL/F/9864-5

## Truth Table

Inputs											Outputs	
Select			Data									
S <sub>2</sub>	S <sub>1</sub>	S <sub>0</sub>	A <sub>7</sub> B <sub>7</sub>	A <sub>6</sub> B <sub>6</sub>	A <sub>5</sub> B <sub>5</sub>	A <sub>4</sub> B <sub>4</sub>	A <sub>3</sub> B <sub>3</sub>	A <sub>2</sub> B <sub>2</sub>	A <sub>1</sub> B <sub>1</sub>	A <sub>0</sub> B <sub>0</sub>	Z <sub>a</sub>	Z <sub>b</sub>
L	L	L								L	L	L
L	L	L								H	L	H
L	L	H							L		L	L
L	L	H							H		L	H
L	H	L						L			L	L
L	H	L						H			L	H
L	H	H									L	L
L	H	H									L	H
H	L	L				L					L	L
H	L	L				H					L	H
H	L	H			L						L	L
H	L	H			H						L	H
H	H	L		L							L	L
H	H	L		H							L	H
H	H	H	L								L	L
H	H	H	H								L	H

H = HIGH Voltage Level  
 L = LOW Voltage Level  
 Blank = X = Don't Care

## Absolute Maximum Ratings

Above which the useful life may be impaired. (Note 1)

If Military/Aerospace specified devices are required, please contact the National Semiconductor Sales Office/Distributors for availability and specifications.

Storage Temperature  $-65^{\circ}\text{C}$  to  $+150^{\circ}\text{C}$

Maximum Junction Temperature ( $T_J$ )  $+150^{\circ}\text{C}$

Case Temperature under Bias ( $T_C$ )  $0^{\circ}\text{C}$  to  $+85^{\circ}\text{C}$

$V_{EE}$  Pin Potential to Ground Pin  $-7.0\text{V}$  to  $+0.5\text{V}$

Input Voltage (DC)  $V_{EE}$  to  $+0.5\text{V}$

Output Current (DC Output HIGH)  $-50\text{mA}$

Operating Range (Note 2)  $-5.7\text{V}$  to  $-4.2\text{V}$

## DC Electrical Characteristics

$V_{EE} = -4.5\text{V}$ ,  $V_{CC} = V_{CCA} = \text{GND}$ ,  $T_C = 0^{\circ}\text{C}$  to  $+85^{\circ}\text{C}$  (Note 3)

Symbol	Parameter	Min	Typ	Max	Units	Conditions (Note 4)	
$V_{OH}$	Output HIGH Voltage	-1025	-955	-880	mV	$V_{IN} = V_{IH}(\text{Max})$ or $V_{IL}(\text{Min})$	Loading with $50\Omega$ to $-2.0\text{V}$
$V_{OL}$	Output LOW Voltage	-1810	-1705	-1620			
$V_{OHC}$	Output HIGH Voltage	-1035			mV	$V_{IN} = V_{IH}(\text{Min})$ or $V_{IL}(\text{Max})$	Loading with $50\Omega$ to $-2.0\text{V}$
$V_{OLC}$	Output LOW Voltage			-1610			
$V_{IH}$	Input HIGH Voltage	-1165		-880	mV	Guaranteed HIGH Signal for All Inputs	
$V_{IL}$	Input LOW Voltage	-1810		-1475	mV	Guaranteed LOW Signal for All Inputs	
$I_{IL}$	Input LOW Current	0.50			$\mu\text{A}$	$V_{IN} = V_{IL}(\text{Min})$	

## DC Electrical Characteristics

$V_{EE} = -4.2\text{V}$ ,  $V_{CC} = V_{CCA} = \text{GND}$ ,  $T_C = 0^{\circ}\text{C}$  to  $+85^{\circ}\text{C}$  (Note 3)

Symbol	Parameter	Min	Typ	Max	Units	Conditions (Note 4)	
$V_{OH}$	Output HIGH Voltage	-1020		-870	mV	$V_{IN} = V_{IH}(\text{Max})$ or $V_{IL}(\text{Min})$	Loading with $50\Omega$ to $-2.0\text{V}$
$V_{OL}$	Output LOW Voltage	-1810		-1605			
$V_{OHC}$	Output HIGH Voltage	-1030			mV	$V_{IN} = V_{IH}(\text{Min})$ or $V_{IL}(\text{Max})$	Loading with $50\Omega$ to $-2.0\text{V}$
$V_{OLC}$	Output LOW Voltage			-1595			
$V_{IH}$	Input HIGH Voltage	-1150		-870	mV	Guaranteed HIGH Signal for All Inputs	
$V_{IL}$	Input LOW Voltage	-1810		-1475	mV	Guaranteed LOW Signal for All Inputs	
$I_{IL}$	Input LOW Current	0.50			$\mu\text{A}$	$V_{IN} = V_{IL}(\text{Min})$	

## DC Electrical Characteristics

$V_{EE} = -4.8\text{V}$ ,  $V_{CC} = V_{CCA} = \text{GND}$ ,  $T_C = 0^{\circ}\text{C}$  to  $+85^{\circ}\text{C}$  (Note 3)

Symbol	Parameter	Min	Typ	Max	Units	Conditions (Note 4)	
$V_{OH}$	Output HIGH Voltage	-1035		-880	mV	$V_{IN} = V_{IH}(\text{Max})$ or $V_{IL}(\text{Min})$	Loading with $50\Omega$ to $-2.0\text{V}$
$V_{OL}$	Output LOW Voltage	-1830		-1620			
$V_{OHC}$	Output HIGH Voltage	-1045			mV	$V_{IN} = V_{IH}(\text{Min})$ or $V_{IL}(\text{Max})$	Loading with $50\Omega$ to $-2.0\text{V}$
$V_{OLC}$	Output LOW Voltage			-1610			
$V_{IH}$	Input HIGH Voltage	-1165		-880	mV	Guaranteed HIGH Signal for All Inputs	
$V_{IL}$	Input LOW Voltage	-1830		-1490	mV	Guaranteed LOW Signal for All Inputs	
$I_{IL}$	Input LOW Current	0.50			$\mu\text{A}$	$V_{IN} = V_{IL}(\text{Min})$	

**Note 1:** Absolute maximum ratings are those values beyond which the device may be damaged or have its useful life impaired. Functional operation under these conditions is not implied.

**Note 2:** Parametric values specified at  $-4.2\text{V}$  to  $-4.8\text{V}$ .

**Note 3:** The specified limits represent the "worst case" value for the parameter. Since these "worst case" values normally occur at the temperature extremes, additional noise immunity and guard banding can be achieved by decreasing the allowable system operating ranges.

**Note 4:** Conditions for testing shown in the tables are chosen to guarantee operation under "worst case" conditions.

**DC Electrical Characteristics**
 $V_{EE} = -4.2V$  to  $-4.8V$  unless otherwise specified,  $V_{CC} = V_{CCA} = GND$ ,  $T_C = 0^\circ C$  to  $+85^\circ C$ 

Symbol	Parameter	Min	Typ	Max	Units	Conditions
$I_{IH}$	Input HIGH Current $S_n$ $A_n, B_n$			265 340	$\mu A$	$V_{IN} = V_{IH} (Max)$
$I_{EE}$	Power Supply Current	-153	-110	-76	mA	Inputs Open

**Ceramic Dual-In-Line Package AC Electrical Characteristics**
 $V_{EE} = -4.2V$  to  $-4.8V$ ,  $V_{CC} = V_{CCA} = GND$ 

Symbol	Parameter	$T_C = 0^\circ C$		$T_C = +25^\circ C$		$T_C = +85^\circ C$		Units	Conditions
		Min	Max	Min	Max	Min	Max		
$t_{PLH}$ $t_{PHL}$	Propagation Delay $A_0-A_7, B_0-B_7$ to Output	0.55	1.65	0.60	1.70	0.65	1.80	ns	<i>Figures 1 &amp; 2</i>
$t_{PLH}$ $t_{PHL}$	Propagation Delay $S_0-S_2$ to Output	1.10	2.80	1.10	2.80	1.20	3.10	ns	
$t_{TLH}$ $t_{THL}$	Transition Time 20% to 80%, 80% to 20%	0.50	1.85	0.55	1.80	0.50	1.80	ns	

**Cerpak AC Electrical Characteristics**
 $V_{EE} = -4.2V$  to  $-4.8V$ ,  $V_{CC} = V_{CCA} = GND$ 

Symbol	Parameter	$T_C = 0^\circ C$		$T_C = +25^\circ C$		$T_C = +85^\circ C$		Units	Conditions
		Min	Max	Min	Max	Min	Max		
$t_{PLH}$ $t_{PHL}$	Propagation Delay $A_0-A_7, B_0-B_7$ to Output	0.55	1.45	0.60	1.50	0.65	1.60	ns	<i>Figures 1 &amp; 2</i>
$t_{PLH}$ $t_{PHL}$	Propagation Delay $S_0-S_2$ to Output	1.10	2.60	1.10	2.60	1.20	2.90	ns	
$t_{TLH}$ $t_{THL}$	Transition Time 20% to 80%, 80% to 20%	0.50	1.75	0.55	1.70	0.50	1.70	ns	

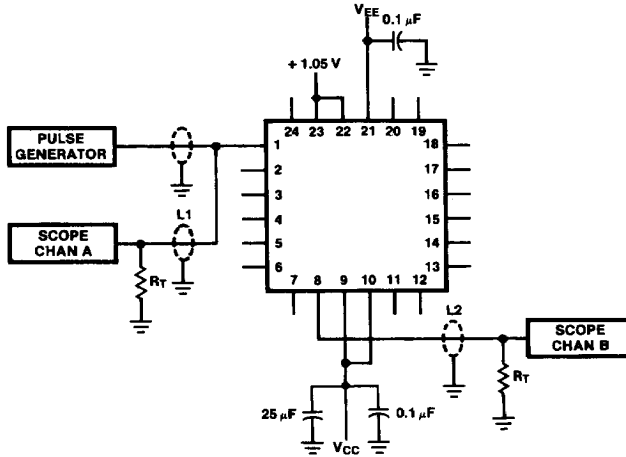

FIGURE 1. AC Test Circuit

TL/F/9864-6

**Notes:**

- $V_{CC}, V_{CCA} = +2V, V_{EE} = -2.5V$
- L1 and L2 = equal length 50Ω impedance lines
- $R_T = 50\Omega$  terminator internal to scope
- Decoupling 0.1 μF from GND to  $V_{CC}$  and  $V_{EE}$
- All unused outputs are loaded with 50Ω to GND
- $C_L$  = Fixture and stray capacitance  $\leq 3$  pF
- Pin numbers shown are for flatpak; for DIP see logic symbol

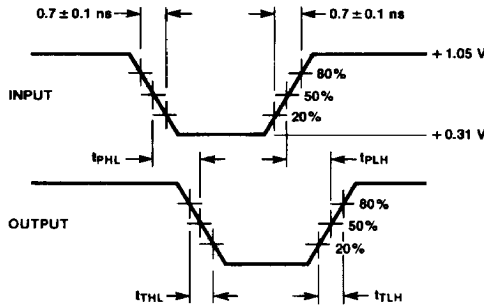

FIGURE 2. Propagation Delay and Transition Times

TL/F/9864-7