

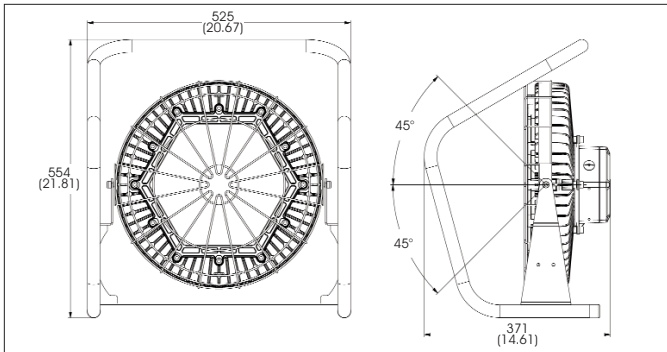

Patent Pending

## SafeSite® LED High Bay Transportable Version



### Certifications & Ratings

#### Standard ATEX/IECEx

#### 9,500lm and 11,000lm Models

- Ex II 2G D Ex d e IIB T5 Gb

#### 12,500lm Models

- Ex II 2G D Ex d e IIB T4 Gb

#### All Standard ATEX/IECEx Models

- Ex tb IIIC T100°C Db IP66
- Certificate numbers: IECEx BAS 10.0074X  
Baseefa 10ATEX0148X

#### Hydrogen Environment ATEX/IECEx Models

- Ex II 2G D Ex d e IIB+H2 T5 Gb
- Ex tb IIIC T100°C Db IP66
- Certificate numbers: IECEx BAS 12.0044X  
Baseefa 12ATEX0070X

#### All Models

- ATEX Zones 1 & 21 and 2 & 22
- CE - Compliant with EN 55015-2006 & EN 61547
- IP66 rated
- RoHS compliant

### Features & Benefits

- L70 rated for > 100,000 hours @ 25°C ambient
- 5 year full performance warranty
- Low power consumption
- Instant on/off operation
- Mercury free, lead free
- Resistant to shock and vibration
- Superior colour rendition index compared to HPS, LPS & MV
- Temperature compensation technology for longer life
- SWB/EPR Cable 3 core 1.5mm<sup>2</sup> CSA or Junction Box option
- One man installation
- Replaces up to 400W HID

#### Order Codes

Part Number	Hydrogen Environments	Junction Box	Initial Fixture Lumens	Typical	Maximum	Lumens Per Watt	Lens	Optic	CCT
THBJA9CMP		•	12,500	172W	195W	73	Toughened Glass	Narrow Circular	cw
THBJA9C4P		•	11,000	150W	165W	73	Toughened Glass	Narrow Circular	cw
THBJA9C4M		•	9,500	150W	165W	63	Toughened Glass	Narrow Circular	cw
THBHJ9C4M	•	•	9,500	150W	165W	63	Toughened Glass	Narrow Circular	cw

Dialight reserves the right to make changes at any time in order to supply the best product possible. The most current version of this document will always be available at: [www.dialight.com/assets/brochures\\_and\\_catalogs/illumination/MDTFSFSTABEU001.pdf](http://www.dialight.com/assets/brochures_and_catalogs/illumination/MDTFSFSTABEU001.pdf)

Warranty Statement: EXCEPT FOR THE WARRANTY EXPRESSLY PROVIDED FOR (HEREIN/ABOVE/BELOW), DIALIGHT DISCLAIMS ANY AND ALL OTHER WARRANTIES, EXPRESS OR IMPLIED, INCLUDING, WITHOUT LIMITATION, ANY WARRANTIES OF MERCHANTABILITY, FITNESS FOR A PARTICULAR PURPOSE, TITLE, AND NON-INFRINGEMENT.

#### Application:

The Dialight SafeSite® Transportable LED High Bay is a high performance, light weight luminaire designed for use in hazardous areas as temporary lighting and for maintenance tasks, such as tank cleaning and sand-blasting. Suitable for oil & gas, chemical, petro-chemical and other potentially explosive industrial environments.

#### Mechanical Information

Fixture Weight: 13.6 kg (30 lbs)

Fixing: Factory installed 10 metre cable

#### Electrical specifications

Operating Voltage: 100-277VAC, 50/60 Hz

Total System Power Consumption: See table

Operating Temp: -40°C to +60°C (-40°F to 140°F)

Harmonics: IEC 61000-3-2

Surge Protection: EN 61000-4-5  
1kV line to line, 2 kV line to ground

THD: <5% (100VAC)  
<10% (230/240VAC)  
<12% (277VAC)

Power Factor: > 0.9

#### Construction

Body: Copper free aluminium

Finish: Yellow powder coated (RAL 1018)

Bracket and wire guard: 316 Stainless Steel

Lens: Tempered glass

#### Photometric Information

CRI: 70

CCT: 6,000K (cool white)

All values typical unless otherwise stated  
All lumen values are typical (tolerance +/- 10%)

