

CAT93CXXXX (1K-16K)

 Supervisory Circuits with Microwire Serial CMOS E²PROM, Precision Reset Controller and Watchdog Timer

FEATURES

- Watchdog Timer
- Programmable Reset Threshold
- Built-in Inadvertent Write Protection
 - V_{CC} Lock Out
- High Speed Operation: 3MHz
- Low Power CMOS Technology
- x 16 or x 8 Selectable Serial Memory
- Self-Timed Write Cycle with Auto-Clear
- Sequential Read
- Fast Nonvolatile Write Cycle: 3ms Max
- Active High or Low Reset Outputs
 - Precision Power Supply Voltage Monitoring
 - 5V, 3.3V and 3V options
- Hardware and Software Write Protection
- Power-Up Inadvertant Write Protection
- 1,000,000 Program/Erase Cycles
- 100 Year Data Retention
- Commercial, Industrial, and Automotive Temperature Ranges
- 2.7-6.0 Volt Operation
- 16 Byte Page Mode

DESCRIPTION

The CAT93CXXXX is a single chip solution to three popular functions of EEPROM memory, precision reset controller and watchdog timer. The serial EEPROM memory of the 93CXXXX can be configured either by 16-bits or by 8-bits. Each register can be written (or read) by using the DI (or DO pin).

The reset function of the 93CXXXX protects the system

during brown out and power up/down conditions. During system failure the watchdog timer feature protects the microcontroller with a reset signal. Catalyst's advanced CMOS technology substantially reduces device power requirements. The 93CXXXX is available in 8-pin DIP, 8-pin TSSOP or 8-pin SOIC packages. It is designed to endure 1,000,000 program/erase cycles and has a data retention of 100 years.

PIN CONFIGURATION

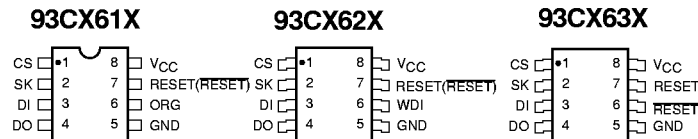

PIN FUNCTIONS

Pin Name	Function
CS	Chip Select
RESET/RESET	Reset I/O
SK	Clock Input
DI	Serial Data Input
DO	Serial Data Output
V _{CC}	+2.7 to 6.0V Power Supply
GND	Ground
ORG	Memory Organization

Note: When the ORG pin is connected to V_{CC}, the X16 organization is selected. When it is connected to ground, the X8 pin is selected. If the ORG pin is left unconnected, then an internal pullup device will select the X16 organization.

BLOCK DIAGRAM

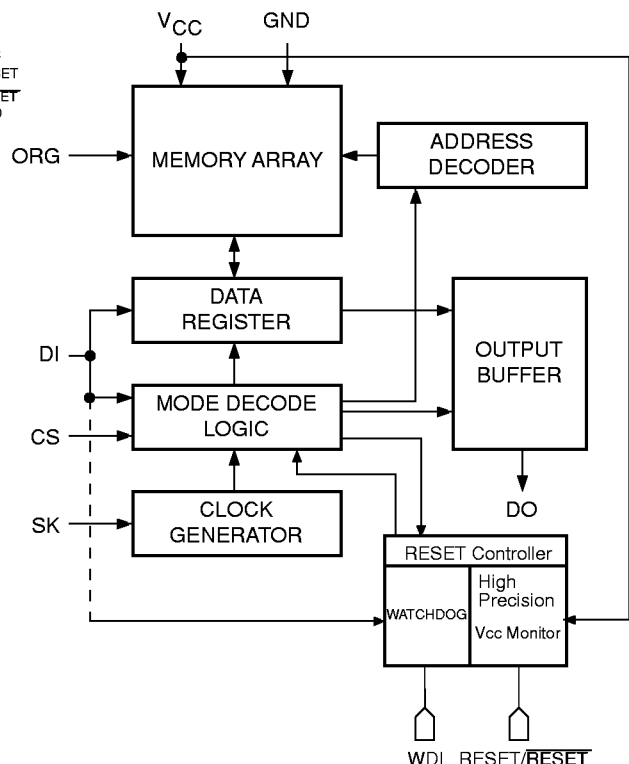

ABSOLUTE MAXIMUM RATINGS*

Temperature Under Bias.....	-55°C to +125°C
Storage Temperature.....	-65°C to +150°C
Voltage on Any Pin with Respect to Ground ⁽¹⁾	-2.0V to +V _{CC} + 2.0V
V _{CC} with Respect to Ground.....	-2.0V to +7.0V
Package Power Dissipation Capability (T _a = 25°C).....	1.0W
Lead Soldering Temperature (10 secs).....	300°C
Output Short Circuit Current ⁽²⁾	100mA

COMMENT

Stresses above those listed under “Absolute Maximum Ratings” may cause permanent damage to the device. These are stress ratings only, and functional operation of the device at these or any other conditions outside of those listed in the operational sections of this specification is not implied. Exposure to any absolute maximum rating for extended periods may affect device performance and reliability.

D.C. OPERATING CHARACTERISTICS

V_{CC} = +2.7V to +6.0V, unless otherwise specified.

Symbol	Parameter	Limits			Units	Test Conditions
		Min.	Typ.	Max.		
I _{CC1}	Power Supply Current (Write)			3	mA	f _{SK} = 1MHz V _{CC} = 5.0V
I _{CC2}	Power Supply Current (Read)			1	mA	f _{SK} = 1MHz V _{CC} = 5.0V
I _{SB1}	Power Supply Current (Standby) (x8 Mode)			10	μA	CS = 0V ORG=GND
I _{SB2}	Power Supply Current (Standby) (x16 Mode)			0	μA	CS=0V ORG=Float or V _{CC}
I _{LI}	Input Leakage Current			1	μA	V _{IN} = 0V to V _{CC}
I _{LO}	Output Leakage Current (Including ORG pin)			1	μA	V _{OUT} = 0V to V _{CC} , CS = 0V
V _{IL1}	Input Low Voltage	-0.1		0.8	V	4.5V ≤ V _{CC} < 5.5V
V _{IH1}	Input High Voltage	2		V _{CC} +1	V	
V _{OL1}	Output Low Voltage			0.4	V	4.5V ≤ V _{CC} < 5.5V I _{OL} = 2.1mA I _{OH} = -400μA
V _{OH1}	Output High Voltage	2.4			V	

Note:

- (1) The minimum DC input voltage is -0.5V. During transitions, inputs may undershoot to -2.0V for periods of less than 20 ns. Maximum DC voltage on output pins is V_{CC} + 0.5V, which may overshoot to V_{CC} + 2.0V for periods of less than 20ns.
(2) Output shorted for no more than one second. No more than one output shorted at a time.

RELIABILITY CHARACTERISTICS

Symbol	Parameter	Min.	Max.	Units	Reference Test Method
N _{END} ⁽¹⁾	Endurance	1,000,000		Cycles/Byte	MIL-STD-883, Test Method 1033
T _{DR} ⁽¹⁾	Data Retention	100		Years	MIL-STD-883, Test Method 1008
V _{ZAP} ⁽¹⁾	ESD Susceptibility	2000		Volts	MIL-STD-883, Test Method 3015
I _{LTH} ⁽¹⁾⁽³⁾	Latch-up	100		mA	JEDEC Standard 17

A.C. CHARACTERISTICS

V_{CC}=2.7V to 6.0V unless otherwise specified.
Output Load is 1 TTL Gate and 100pF

SYMBOL	PARAMETER	Limits					UNITS	Test Conditions
		V _{CC} = 2.7V -6V		V _{CC} = 4.5V-5.5V		Test		
		Min.	Max.	Min.	Max.			
t _{CS}	CS Setup Time	250		50		ns	C _L = 100pF	
t _{CSH}	CS Hold Time	0		0		ns		
t _{DIS}	DI Setup Time	250		50		ns		
t _{DIH}	DI Hold Time	250		50		ns		
t _{PD1}	Output Delay to 1		0.5		0.1	μs		
t _{PD0}	Output Delay to 0		0.5		0.1	μs		
t _{HZ} ⁽¹⁾	Output Delay to High-Z		500		100	ns		
t _{EW}	Program/Erase Pulse Width		5		5	ms		
t _{CSMIN}	Minimum CS Low Time	0.5		0.1		μs		
t _{SKHI}	Minimum SK High Time	0.5		0.1		μs		
t _{SKLOW}	Minimum SK Low Time	0.5		0.1		μs		
t _{SV}	Output Delay to Status Valid		0.5		0.1	μs		
SK _{MAX}	Maximum Clock Frequency	DC	1000	DC	3000	KHZ		

Power-Up Timing⁽¹⁾⁽²⁾

Symbol	Parameter	Max.	Units
t _{PUR}	Power-up to Read Operation	1	ms
t _{PUW}	Power-up to Write Operation	1	ms

CAPACITANCE T_A = 25°C, f = 1.0 MHz, V_{CC} = 5V

Symbol	Test	Max.	Units	Conditions
C _{I/O} ⁽¹⁾	Input/Output Capacitance	8	pF	V _{I/O} = 0V
C _{IN} ⁽¹⁾	Input Capacitance	6	pF	V _{IN} = 0V

Note:

- (1) This parameter is tested initially and after a design or process change that affects the parameter.
(2) t_{PUR} and t_{PUW} are the delays required from the time V_{CC} is stable until the specified operation can be initiated.
(3) Latch-up protection is provided for stresses up to 100 mA on address and data pins from -1V to V_{CC} +1V.

INSTRUCTION SET

Instruction	Device Type	Start Bit	Opcode	Address		Data		Comments
				x8	x16	x8	x16	
READ	93C46XX	1	10	A6-A0	A5-A0			Read Address AN-A0
	93C56XX ⁽¹⁾	1	10	A8-A0	A7-A0			
	93C66XX	1	10	A8-A0	A7-A0			
	93C57XX	1	10	A7-A0	A6-A0			
	93C86XX	1	10	A10-A0	A9-A0			
ERASE	93C46XX	1	11	A6-A0	A5-A0			Clear Address AN-A0
	93C56XX ⁽¹⁾	1	11	A8-A0	A7-A0			
	93C66XX	1	11	A8-A0	A7-A0			
	93C57XX	1	11	A7-A0	A6-A0			
	93C86XX	1	11	A10-A0	A9-A0			
WRITE	93C46XX	1	01	A6-A0	A5-A0	D7-D0	D15-D0	Write Address AN-A0
	93C56XX ⁽¹⁾	1	01	A8-A0	A7-A0	D7-D0	D15-D0	
	93C66XX	1	01	A8-A0	A7-A0	D7-D0	D15-D0	
	93C57XX	1	01	A7-A0	A6-A0	D7-D0	D15-D0	
	93C86XX	1	01	A10-A0	A9-A0	D7-D0	D15-D0	
EWEN	93C46XX	1	00	11XXXXX	11XXXX			Write Enable
	93C56XX	1	00	11XXXXXXXX	11XXXXXXXX			
	93C66XX	1	00	11XXXXXXXX	11XXXXXXXX			
	93C57XX	1	00	11XXXXXX	11XXXXXX			
	93C86XX	1	00	11XXXXXXXXXX	11XXXXXXXXXX			
EWDS	93C46XX	1	00	00XXXXX	00XXXX			Write Disable
	93C56XX	1	00	00XXXXXXXX	00XXXXXXXX			
	93C66XX	1	00	00XXXXXXXX	00XXXXXXXX			
	93C57XX	1	00	00XXXXXX	00XXXXXX			
	93C86XX	1	00	00XXXXXXXXXX	00XXXXXXXXXX			
ERAL	93C46XX	1	00	10XXXXX	10XXXX			Clear All Addresses
	93C56XX	1	00	10XXXXXXXX	10XXXXXXXX			
	93C66XX	1	00	10XXXXXXXX	10XXXXXXXX			
	93C57XX	1	00	10XXXXXX	10XXXXXX			
	93C86XX	1	00	10XXXXXXXXXX	10XXXXXXXXXX			
WRAL	93C46XX	1	00	01XXXXX	01XXXX	D7-D0	D15-D0	Write All Addresses
	93C56XX	1	00	01XXXXXXXX	01XXXXXXXX	D7-D0	D15-D0	
	93C66XX	1	00	01XXXXXXXX	01XXXXXXXX	D7-D0	D15-D0	
	93C57XX	1	00	01XXXXXX	01XXXXXX	D7-D0	D15-D0	
	93C86XX	1	00	01XXXXXXXXXX	01XXXXXXXXXX	D7-D0	D15-D0	

Note:

(1) Address bit A8 for 256x8 ORG and A7 for 128x16 ORG are "Don't Care" bits, but must be kept at either a "1" or "0" for READ, WRITE and ERASE commands.

RESET CIRCUIT CHARACTERISTICS

Symbol	Parameter	Min.	Max.	Units
t_{GLITCH}	Glitch Reject Pulse Width		100	ns
V_{RT}	Reset Threshold Hysteresis	15		mV
V_{OLRS}	Reset Output Low Voltage ($I_{OLRS}=1mA$)		0.4	V
V_{OHRS}	Reset Output High Voltage	$V_{CC}-0.75$		V
V_{TH}	Reset Threshold ($V_{CC}=5V$) (93CXXXX-45)	4.50	4.75	V
	Reset Threshold ($V_{CC}=5V$) (93CXXXX-42)	4.25	4.50	
	Reset Threshold ($V_{CC}=3.3V$) (93CXXXX-30)	3.00	3.15	
	Reset Threshold ($V_{CC}=3.3V$) (93CXXXX-28)	2.85	3.00	
	Reset Threshold ($V_{CC}=3V$) (93CXXXX-25)	2.55	2.70	
t_{PURST}	Power-Up Reset Timeout	130	270	ms
t_{RPD}	V_{TH} to RESET Output Delay		5	μs
V_{RVALID}	RESET Output Valid	1		V

Figure 1. RESET Output Timing

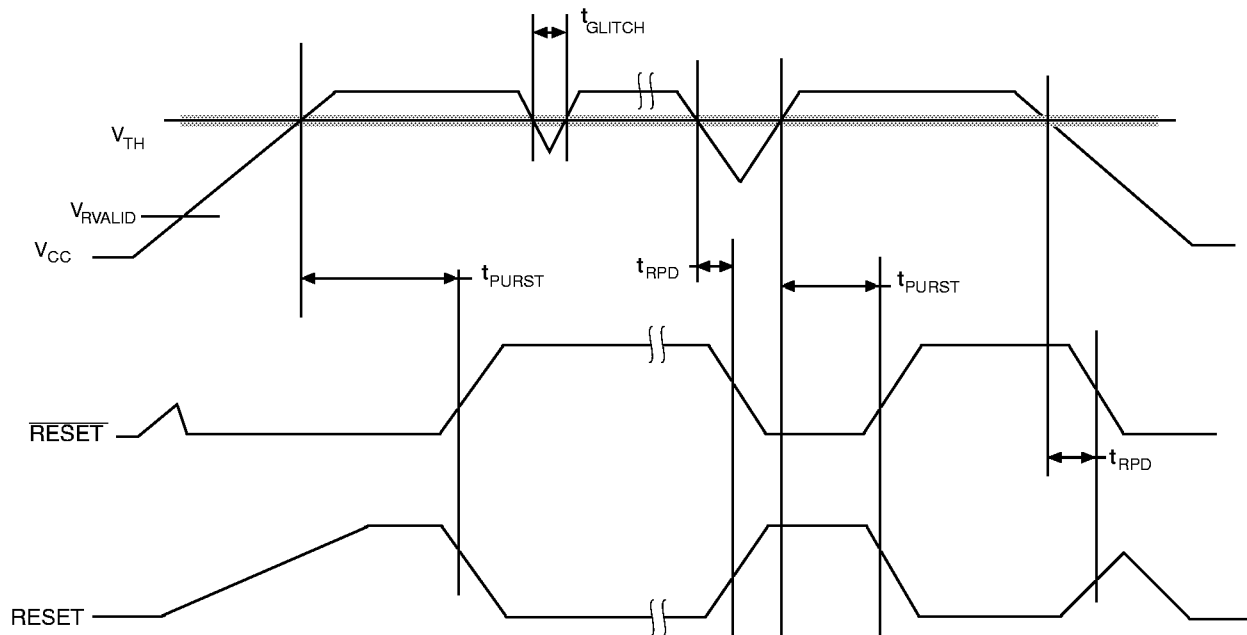

DEVICE OPERATION

Reset Controller Description

The CAT93CXXXX provides a precision RESET controller that ensures correct system operation during brown-out and power-up/down conditions. It is configured with open drain RESET outputs. During power-up, the RESET outputs remain active until V_{CC} reaches the V_{TH} threshold and will continue driving the outputs for approximately 200ms (t_{PURST}) after reaching V_{TH} . After the t_{PURST} timeout interval, the device will cease to drive reset outputs. At this point the reset outputs will be pulled up or down by their respective pull up/pull down devices. During power-down, the RESET outputs will begin driving active when V_{CC} falls below V_{TH} . The RESET outputs will be valid so long as V_{CC} is $>1.0V$ (V_{RVALID}).

The RESET pins are I/Os; therefore, the CAT93CXXXX can act as a signal conditioning circuit for an externally applied reset. The inputs are level triggered; that is, the RESET input in the 93CXXXX will initiate a reset timeout after detecting a high and the \overline{RESET} input in the 93CXXXX will initiate a reset timeout after detecting a low.

Watchdog Timer

The Watchdog Timer provides an independent protection for microcontrollers. During a system failure, the CAT93CXXXX will respond with a reset signal after a time-out interval of 1.6 seconds for lack of activity.

As long as the reset signal is asserted, the Watchdog Timer will not count and will stay cleared.

Hardware Data Protection

The 93CXXXX is designed with a V_{CC} lock out data protection feature to provide a high degree of data integrity.

The V_{CC} sense provides write protection when V_{CC} falls below the reset threshold value. The V_{CC} lock out inhibits writes to the serial EEPROM whenever V_{CC} falls below (power down) or until V_{CC} reaches the reset threshold (power up).

Reset Threshold Voltage

From the factory the 93CXXXX is offered in five different variations of reset threshold voltages. They are 4.50-4.75V, 4.25-4.50V, 3.00-3.15V, 2.85-3.00V and 2.55-2.70V. To provide added flexibility to design engineers using this product, the 93CXXXX is designed with an additional feature of programming the reset threshold voltage. This allows the user to change

the existing reset threshold voltage to one of the other four reset threshold voltages. Once the reset threshold voltage is selected it will not change even after cycling the power, unless the user uses the programmer to change the reset threshold voltage. However, the programming function is available only through external program manufacturers. Please call Catalyst for a list of programmer manufacturers which support this function.

Memory Functional Description

The CAT93CXXXX is a 1024/2048/4096/16,384-bit non-volatile memory intended for use with industry standard microprocessors. The CAT93CXXXX can be organized as either registers of 16 bits or 8 bits. When organized as X16, seven 9-bit instructions for 93C46XX; seven 10-bit instructions for 93C57XX; seven 11-bit instructions for 93C56XX and 93C66XX; seven 13-bit instructions for 93C86XX; control the reading, writing and erase operations of the device. When organized as X8, seven 10-bit instructions for 93C46XX; seven 11-bit instructions for 93C57; seven 12-bit instructions for 93C56 and 93C66; seven 14-bit instructions for 93C86; control the reading, writing and erase operations of the device. The CAT93CXXXX operates on a single power supply and will generate on chip, the high voltage required during any write operation.

Instructions, addresses, and write data are clocked into the DI pin on the rising edge of the clock (SK). The DO pin is normally in a high impedance state except when reading data from the device, or when checking the ready/busy status after a write operation.

The ready/busy status can be determined after the start of a write operation by selecting the device (CS high) and polling the DO pin; DO low indicates that the write operation is not completed, while DO high indicates that the device is ready for the next instruction. If necessary, the DO pin may be placed back into a high impedance state during chip select by shifting a dummy "1" into the DI pin. The DO pin will enter the high impedance state on the falling edge of the clock (SK). Placing the DO pin into the high impedance state is recommended in applications where the DI pin and the DO pin are to be tied together to form a common DI/O pin.

The format for all instructions sent to the device is a logical "1" start bit, a 2-bit (or 4-bit) opcode, 6-bit (93C46XX)/7-bit (93C57XX)/ 8-bit (93C56XX or 93C66XX)/10-bit (93C86XX) (an additional bit when organized X8) and for write operations a 16-bit data field (8-bit for X8 organizations).

Read

Upon receiving a READ command and an address (clocked into the DI pin), the DO pin of the CAT93CXXXX will come out of the high impedance state and, after sending an initial dummy zero bit, will begin shifting out the data addressed (MSB first). The output data bits will toggle on the rising edge of the SK clock and are stable after the specified time delay (t_{PD0} or t_{PD1})

For the 93CXXXX, after the initial data word has been shifted out and CS remains asserted with the SK clock continuing to toggle, the device will automatically increment to the next address and shift out the next data word in a sequential READ mode. As long as CS is continuously asserted and SK continues to toggle, the device will keep incrementing to the next address automatically until it reaches to the end of the address space, then loops back to address 0. In the sequential READ mode, only the initial data word is preceded by a dummy zero bit. All subsequent data words will follow without a dummy zero bit.

Write

After receiving a WRITE command, address and the data, the CS (Chip Select) pin must be deselected for a minimum of t_{CSMIN} . The falling edge of CS will start the self clocking clear and data store cycle of the memory location specified in the instruction. The clocking of the SK pin is not necessary after the device has entered the self clocking mode. The ready/busy status of the CAT93CXXXX can be determined by selecting the device and polling the DO pin. Since this device features Auto-Clear before write, it is NOT necessary to erase a memory location before it is written into.

Page Write

The 93CXXXX writes up to 16 bytes (8 words for x16 format) of data in a single write cycle, using the page write operation. The page write operation is initiated in the same manner as the byte (word for x16 format) write operation. However, instead of terminating after the initial byte (word for x16 format) is transmitted, the host

Figure 2. Synchronous Data Timing

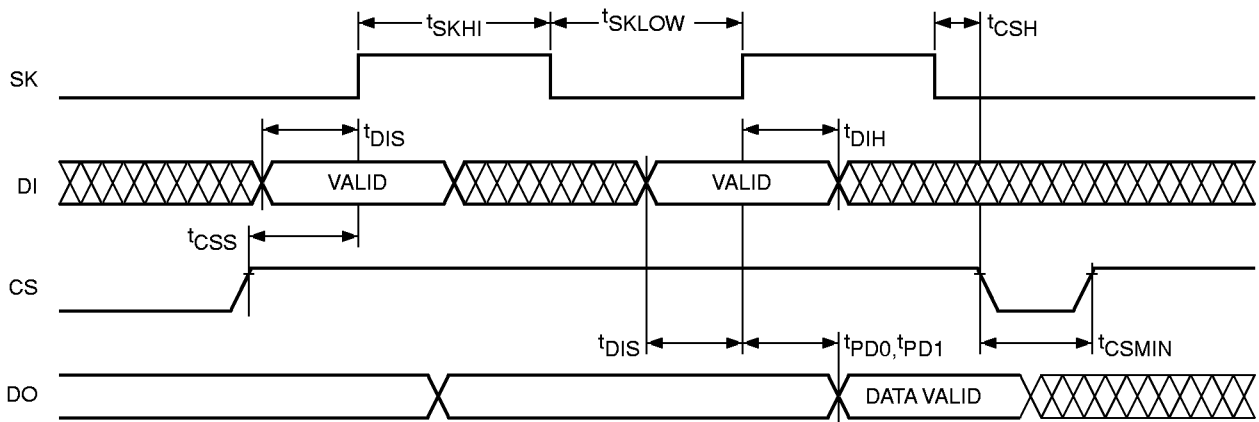
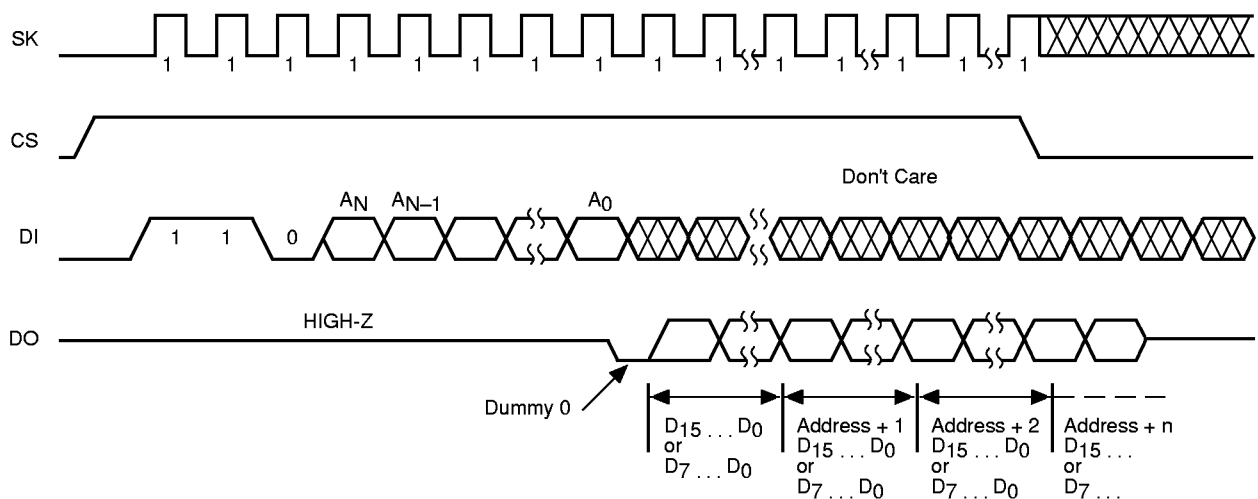

Figure 3. Read Instruction Timing



can then continue to clock in 8-bit (16-bit for x16 format) data to be written to the next higher address. Internally, the address pointer is incremented after each group of eight clocks (16 clocks for x16 format). If the host transmits more than 16 bytes (8 words for x16 format) the address counter ‘wraps around’ and previously transmitted data will be overwritten.

After receiving a WRITE command, address and the data, the CS (Chip Select) pin must be deselected for a minimum of t_{CSMIN} . The falling edge of CS will start the self clocking clear and data store cycle of the memory location specified in the instruction. The clocking of the SK pin is not necessary after the device has entered the self clocking mode. The ready/busy status of the CAT93CXXXX can be determined by selecting the device and polling the DO pin. Since this device features Auto-Clear before write, it is NOT necessary to erase a memory location before it is written into.

Erase

Upon receiving an ERASE command and address, the CS (Chip Select) pin must be deasserted for a minimum of t_{CSMIN} . The falling edge of CS will start the self clocking clear cycle of the selected memory location. The clocking of the SK pin is not necessary after the device has entered the self clocking mode. The ready/busy status of the CAT93CXXXX can be determined by selecting the device and polling the DO pin. Once cleared, the content of a cleared location returns to a logical “1” state.

Figure 4. Write Instruction Timing

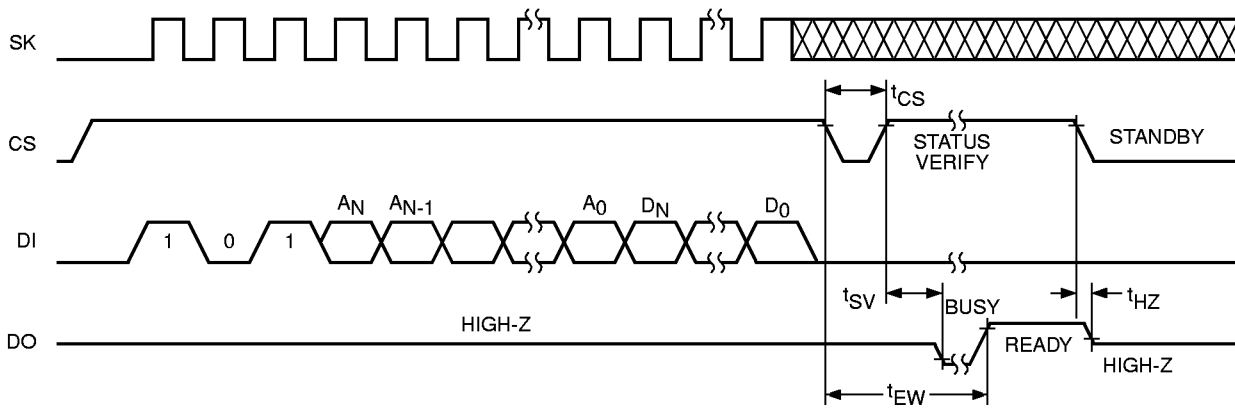
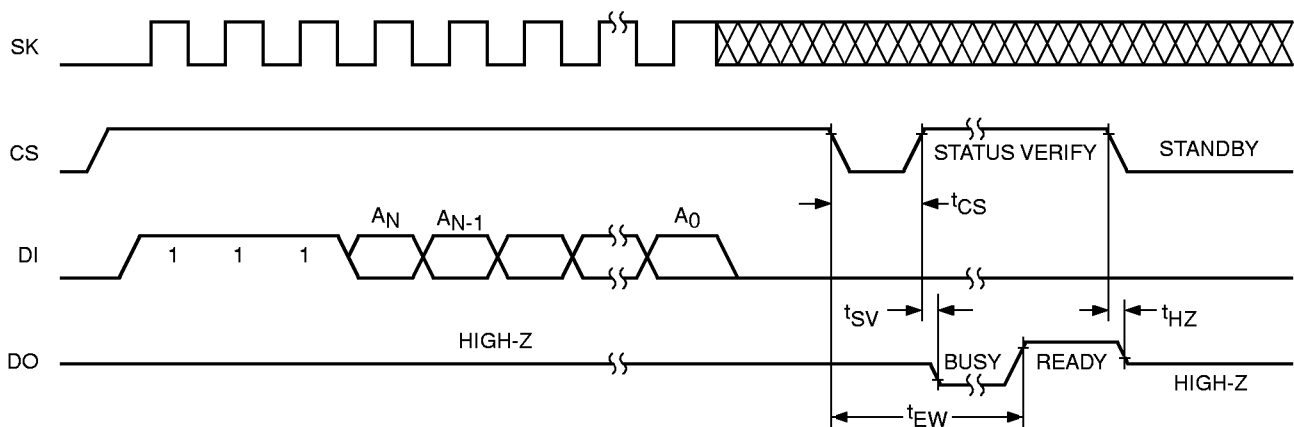

Figure 5. Erase Instruction Timing



Erase/Write Enable and Disable

The CAT93CXXXX powers up in the write disable state. Any writing after power-up or after an EWDS (write disable) instruction must first be preceded by the EWEN (write enable) instruction. Once the write instruction is enabled, it will remain enabled until power to the device is removed, or the EWDS instruction is sent. The EWDS instruction can be used to disable all CAT93CXXXX write and clear instructions, and will prevent any accidental writing or clearing of the device. Data can be read normally from the device regardless of the write enable/disable status.

Erase All

Upon receiving an ERAL command, the CS (Chip Select) pin must be deselected for a minimum of t_{CSMIN} . The falling edge of CS will start the self clocking clear cycle of all memory locations in the device. The clocking of the SK pin is not necessary after the device has

entered the self clocking mode. The ready/busy status of the CAT93CXXXX can be determined by selecting the device and polling the DO pin. Once cleared, the contents of all memory bits return to a logical “1” state.

Write All

Upon receiving a WRAL command and data, the CS (Chip Select) pin must be deselected for a minimum of t_{CSMIN} . The falling edge of CS will start the self clocking data write to all memory locations in the device. The clocking of the SK pin is not necessary after the device has entered the self clocking mode. The ready/busystatus of the CAT93CXXXX can be determined by selecting the device and polling the DO pin. It is not necessary for all memory locations to be cleared before the WRAL command is executed.

Figure 6. EWEN/EWDS Instruction Timing

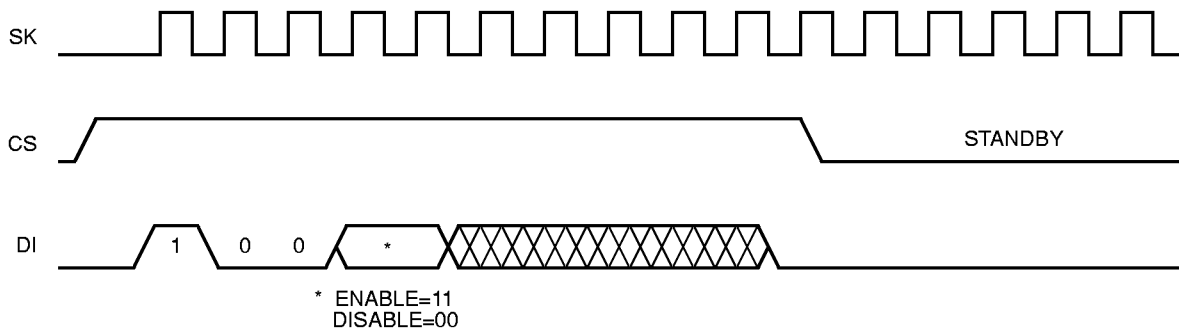

Figure 7. ERAL Instruction Timing

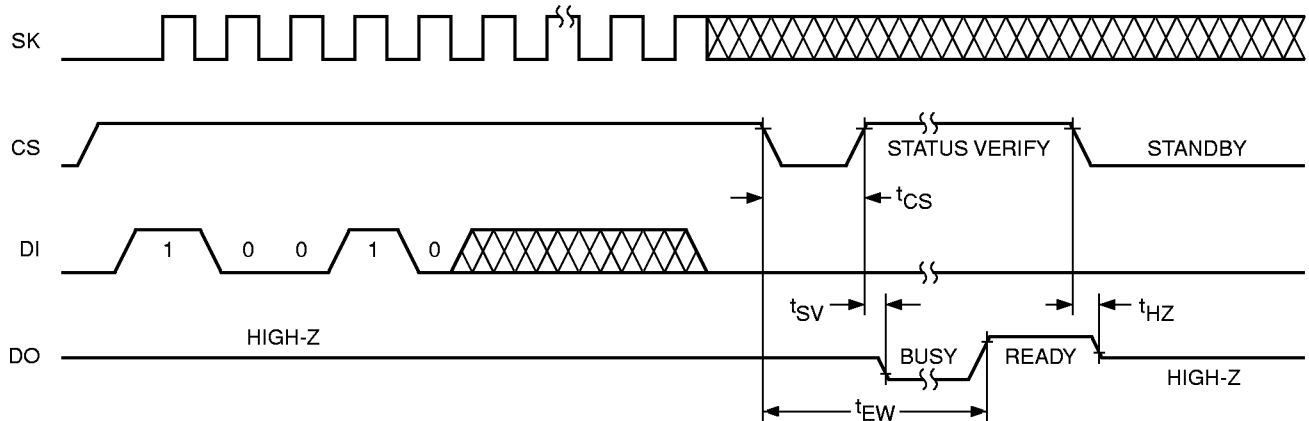
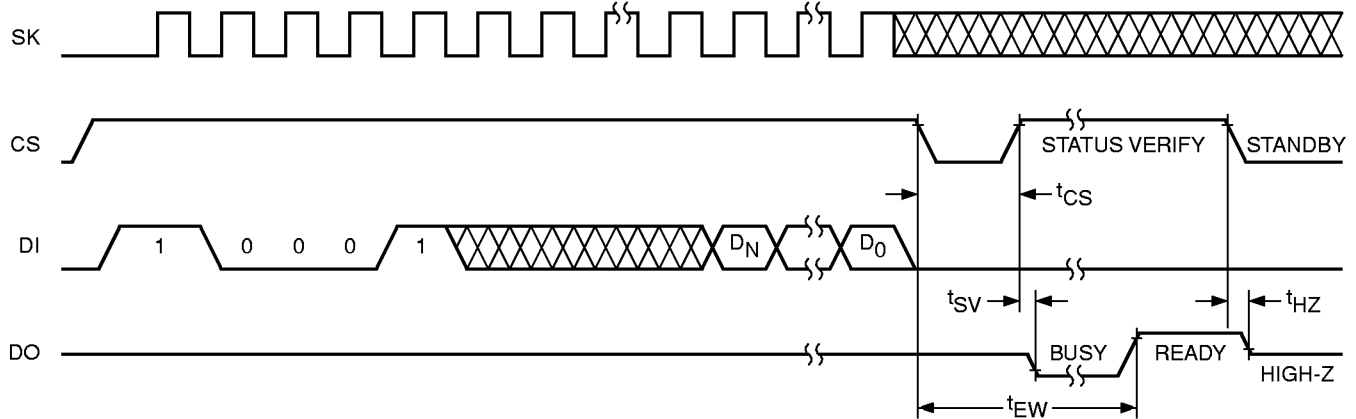
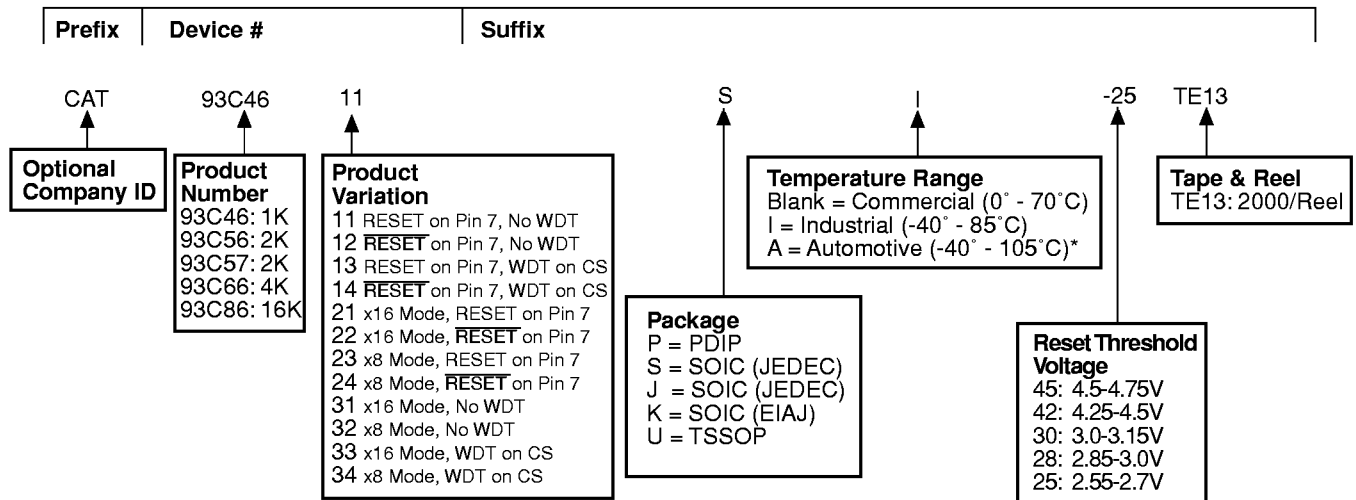

Figure 8. WRAL Instruction Timing



Ordering Information



* -40° to +125°C is available upon request

Note:

(1) The device used in the above example is a 93C4611SI-25TE13 (1K EEPROM, Reset on pin 7 & No WDT, SOIC, Industrial Temperature, 2.55V to 2.7 V Reset threshold voltage, Tape & Reel).