

LM117
LM217
LM317

**THREE-TERMINAL
 ADJUSTABLE POSITIVE
 VOLTAGE REGULATORS**

**SILICON MONOLITHIC
 INTEGRATED CIRCUIT**

3

**THREE-TERMINAL ADJUSTABLE
 OUTPUT POSITIVE VOLTAGE REGULATORS**

The LM117/217/317 are adjustable 3-terminal positive voltage regulators capable of supplying in excess of 1.5 A over an output voltage range of 1.2 V to 37 V. These voltage regulators are exceptionally easy to use and require only two external resistors to set the output voltage. Further, they employ internal current limiting, thermal shutdown and safe area compensation, making them essentially blow-out proof.

The LM117 series serve a wide variety of applications including local, on card regulation. This device can also be used to make a programmable output regulator, or by connecting a fixed resistor between the adjustment and output, the LM117 series can be used as a precision current regulator.

- Output Current in Excess of 1.5 Ampere in K and T Suffix Packages
- Output Current in Excess of 0.5 Ampere in H Suffix Package
- Output Adjustable between 1.2 V and 37 V
- Internal Thermal Overload Protection
- Internal Short-Circuit Current Limiting Constant with Temperature
- Output Transistor Safe-Area Compensation
- Floating Operation for High Voltage Applications
- Standard 3-lead Transistor Packages
- Eliminates Stocking Many Fixed Voltages

STANDARD APPLICATION

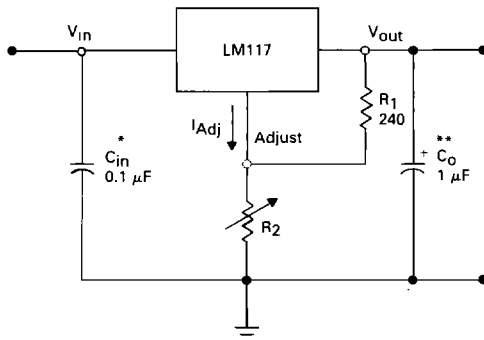

* = C_{in} is required if regulator is located an appreciable distance from power supply filter.

** = C_o is not needed for stability, however it does improve transient response.

$$V_{out} = 1.25 V \left(1 + \frac{R_2}{R_1} \right) + I_{Adj} R_2$$

Since I_{Adj} is controlled to less than 100 μA , the error associated with this term is negligible in most applications.

**K SUFFIX
 METAL PACKAGE
 CASE 1**

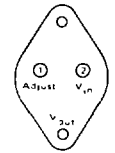
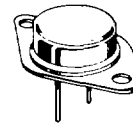

(Bottom View)

**CASE
 IS OUTPUT**

Pins 1 and 2 electrically isolated from case.
 Case is third electrical connection.

**T SUFFIX
 PLASTIC PACKAGE
 CASE 221A**

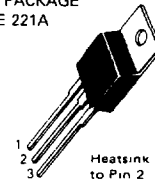

**PIN 1 ADJUST
 2. V_{out}
 3. V_{in}**

Heatsink surface connected
 to Pin 2

**H SUFFIX
 METAL PACKAGE
 CASE 79**

**CASE
 IS OUTPUT**

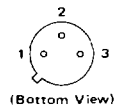
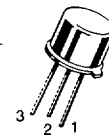

(Bottom View)

**PIN 1 V_{in}
 2 ADJUST
 3 V_{out}**

ORDERING INFORMATION

Device	Tested Operating Temperature Range	Package
LM117H LM117K	$T_J = -55^\circ C$ to $+150^\circ C$	Metal Can Metal Power
LM217H LM217K	$T_J = -25^\circ C$ to $+150^\circ C$	Metal Can Metal Power
LM317H LM317K LM317T	$T_J = 0^\circ C$ to $-125^\circ C$	Metal Can Metal Power Plastic Power
LM317BT#	$T_J = -40^\circ C$ to $+125^\circ C$	Plastic Power

#Automotive temperature range selections are available with special test conditions and additional tests. Contact your local Motorola sales office for information.

LM117, LM217, LM317

MAXIMUM RATINGS

Rating	Symbol	Value	Unit
Input-Output Voltage Differential	$V_I - V_O$	40	Vdc
Power Dissipation	P_D	Internally Limited	
Operating Junction Temperature Range LM117 LM217 LM317	T_J	-55 to +150 -25 to +150 0 to +150	°C
Storage Temperature Range	T_{stg}	-65 to +150	°C

ELECTRICAL CHARACTERISTICS ($V_I - V_O = 5.0$ V; $I_O = 0.5$ A for K and T packages; $I_O = 0.1$ A for H package; $T_J = T_{low}$ to T_{high} [see Note 1]; I_{max} and P_{max} per Note 2; unless otherwise specified.)

Characteristic	Figure	Symbol	LM117/217			LM317			Unit
			Min	Typ	Max	Min	Typ	Max	
Line Regulation (Note 3) $T_A = 25^\circ\text{C}$, $3.0\text{ V} \leq V_I - V_O \leq 40\text{ V}$	1	Reg _{line}	—	0.01	0.02	—	0.01	0.04	%/V
Load Regulation (Note 3) $T_A = 25^\circ\text{C}$, $10\text{ mA} \leq I_O \leq I_{max}$ $V_O \leq 5.0\text{ V}$ $V_O \geq 5.0\text{ V}$	2	Reg _{load}	—	5.0 0.1	15 0.3	—	5.0 0.1	25 0.5	mV %/V _O
Thermal Regulation ($T_A = +25^\circ\text{C}$) 20 ms Pulse		—	—	0.02	0.07	—	0.03	0.07	%/W
Adjustment Pin Current	3	I_{Adj}	—	50	100	—	50	100	μA
Adjustment Pin Current Change $2.5\text{ V} \leq V_I - V_O \leq 40\text{ V}$ $10\text{ mA} \leq I_L \leq I_{max}$, $P_D \leq P_{max}$	1,2	ΔI_{Adj}	—	0.2	5.0	—	0.2	5.0	μA
Reference Voltage (Note 4) $3.0\text{ V} \leq V_I - V_O \leq 40\text{ V}$ $10\text{ mA} \leq I_O \leq I_{max}$, $P_D \leq P_{max}$	3	V_{ref}	1.2	1.25	1.3	1.2	1.25	1.3	V
Line Regulation (Note 3) $3.0\text{ V} \leq V_I - V_O \leq 40\text{ V}$	1	Reg _{line}	—	0.02	0.05	—	0.02	0.07	%/V
Load Regulation (Note 3) $10\text{ mA} \leq I_O \leq I_{max}$ $V_O \leq 5.0\text{ V}$ $V_O \geq 5.0\text{ V}$	2	Reg _{load}	—	20 0.3	50 1.0	—	20 0.3	70 1.5	mV %/V _O
Temperature Stability ($T_{low} \leq T_J \leq T_{high}$)	3	T_S	—	0.7	—	—	0.7	—	%/V _O
Minimum Load Current to Maintain Regulation ($V_I - V_O = 40\text{ V}$)	3	I_{Lmin}	—	3.5	5.0	—	3.5	10	mA
Maximum Output Current $V_I - V_O \leq 15\text{ V}$, $P_D \leq P_{max}$ K and T Packages H Package $V_I - V_O = 40\text{ V}$, $P_D \leq P_{max}$, $T_A = 25^\circ\text{C}$ K and T Packages H Package	3	I_{max}	1.5 0.5 0.25 —	2.2 0.8 0.4 0.07	— — — —	1.5 0.5 0.15 —	2.2 0.8 0.4 0.07	— — — —	A
RMS Noise, % of V_O $T_A = 25^\circ\text{C}$, $10\text{ Hz} \leq f \leq 10\text{ kHz}$	—	N	—	0.003	—	—	0.003	—	%/V _O
Ripple Rejection, $V_O = 10\text{ V}$, $f = 120\text{ Hz}$ (Note 5) Without C_{Adj} $C_{Adj} = 10\text{ μF}$	4	RR	— 66	65 80	— —	— 66	65 80	— —	dB
Long-Term Stability, $T_J = T_{high}$ (Note 6) $T_A = 25^\circ\text{C}$ for Endpoint Measurements	3	S	—	0.3	1.0	—	0.3	1.0	%/1.0 k Hrs.
Thermal Resistance Junction to Case H Package K Package T Package	—	$R_{\theta JC}$	— — —	12 2.3 —	15 3.0 —	— — —	12 2.3 5.0	15 3.0 —	°C/W

NOTES: (1) $T_{low} = -55^\circ\text{C}$ for LM117 $T_{high} = +150^\circ\text{C}$ for LM117
 $= -25^\circ\text{C}$ for LM217 $= +150^\circ\text{C}$ for LM217
 $= 0^\circ\text{C}$ for LM317 $= +125^\circ\text{C}$ for LM317

(2) $I_{max} = 1.5\text{ A}$ for K and T Packages
 $= 0.5\text{ A}$ for H Package
 $P_{max} = 20\text{ W}$ for K Package
 $= 20\text{ W}$ for T Package
 $= 2.0\text{ W}$ for H Package

(3) Load and line regulation are specified at constant junction temperature. Changes in V_O due to heating effects must

be taken into account separately. Pulse testing with low duty cycle is used.

(4) Selected devices with tightened tolerance reference voltage available.

(5) C_{ADJ} , when used, is connected between the adjustment pin and ground.

(6) Since Long-Term Stability cannot be measured on each device before shipment, this specification is an engineering estimate of average stability from lot to lot.

LM117, LM217, LM317

SCHEMATIC DIAGRAM

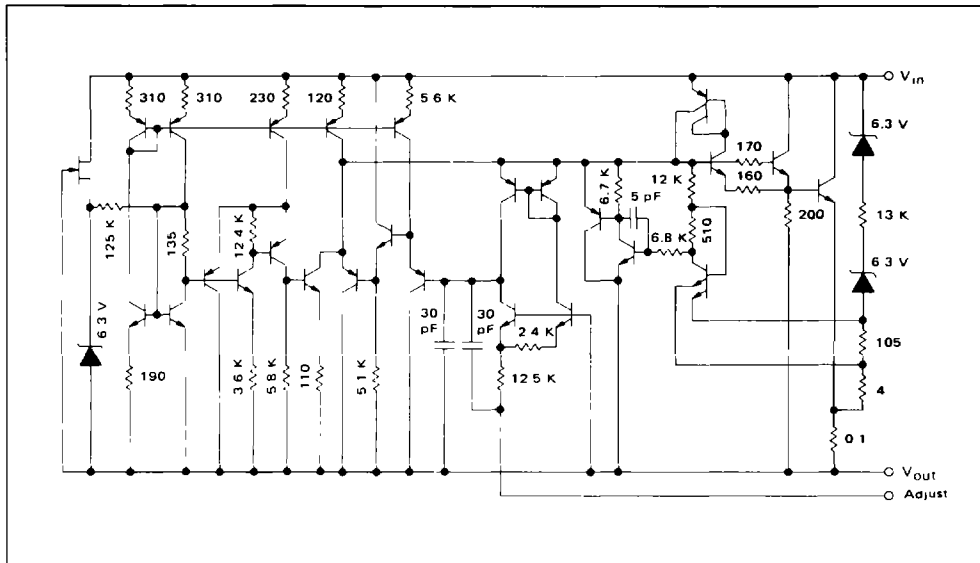

3

FIGURE 1 - LINE REGULATION AND ΔI_{Adj} /LINE TEST CIRCUIT

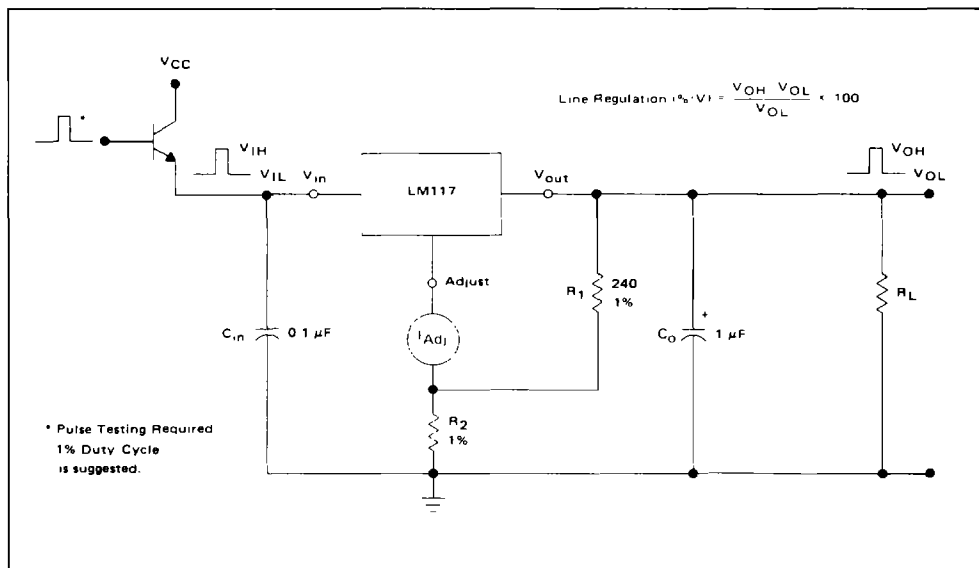

LM117, LM217, LM317

FIGURE 2 – LOAD REGULATION AND ΔI_{Adj} /LOAD TEST CIRCUIT

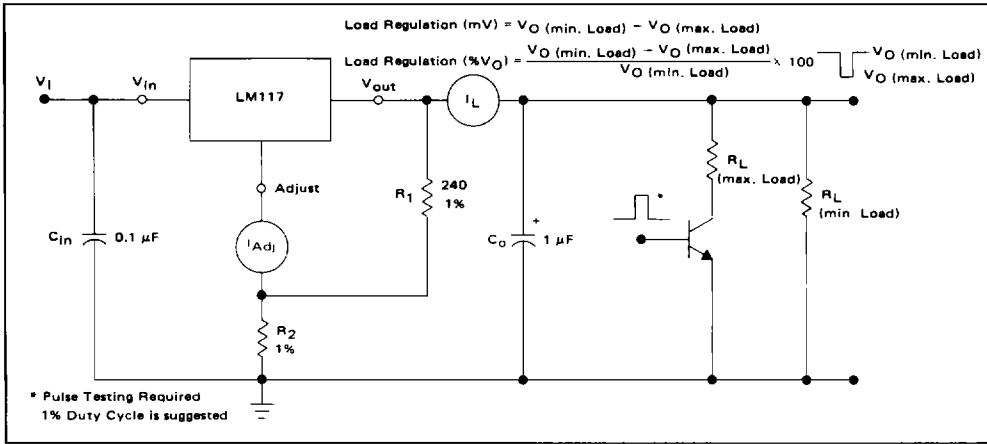

FIGURE 3 – STANDARD TEST CIRCUIT

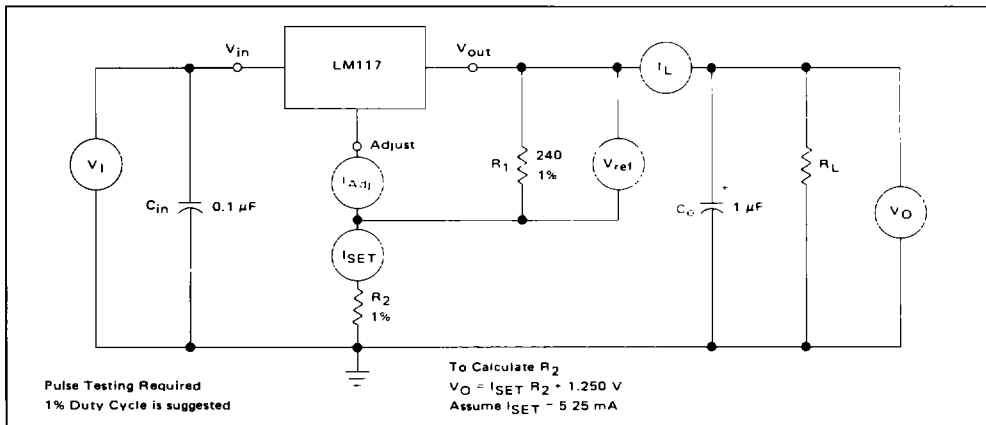
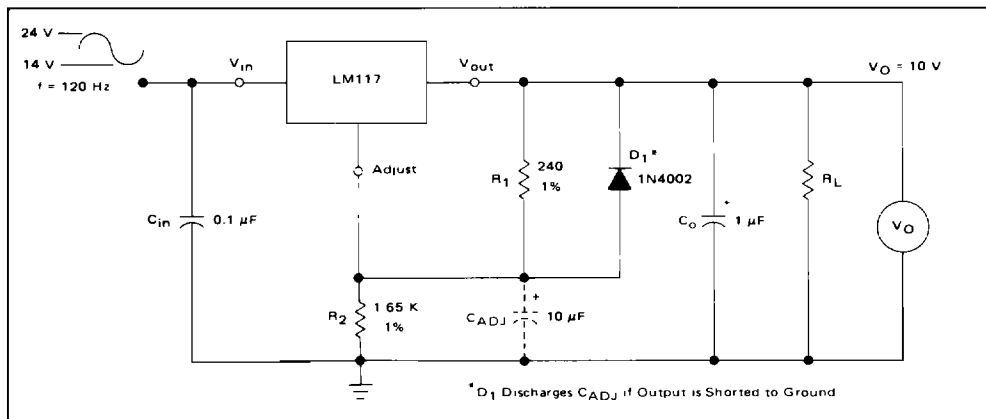

FIGURE 4 – RIPPLE REJECTION TEST CIRCUIT



LM117, LM217, LM317

FIGURE 5 – LOAD REGULATION

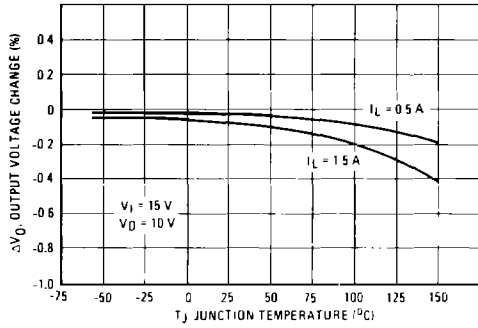

FIGURE 6 – CURRENT LIMIT

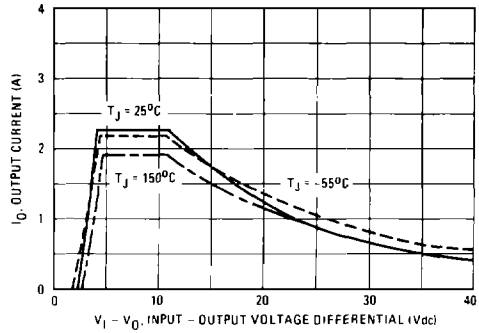

FIGURE 7 – ADJUSTMENT PIN CURRENT

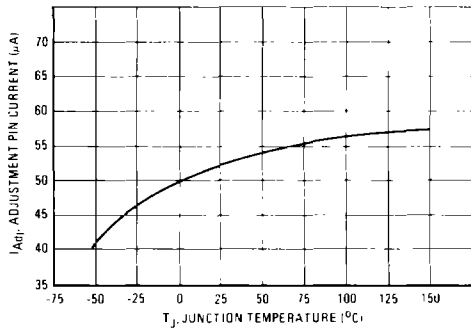

FIGURE 8 – DROPOUT VOLTAGE

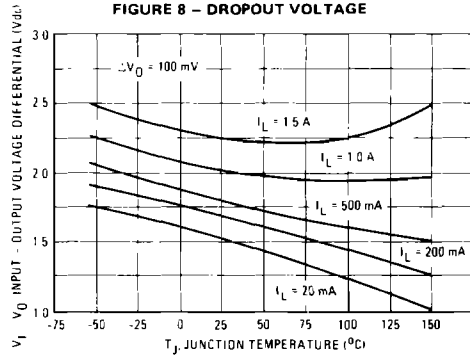

FIGURE 9 – TEMPERATURE STABILITY

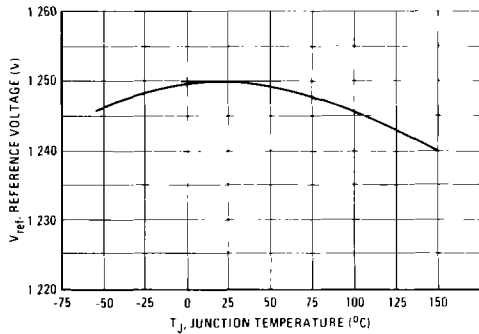
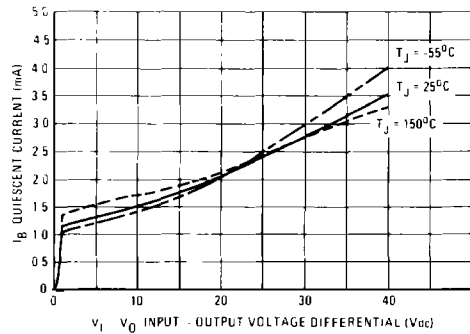

FIGURE 10 – MINIMUM OPERATING CURRENT



LM117, LM217, LM317

3

FIGURE 11 — RIPPLE REJECTION versus OUTPUT VOLTAGE

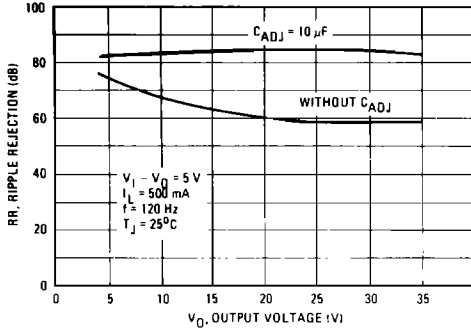

FIGURE 12 — RIPPLE REJECTION versus OUTPUT CURRENT

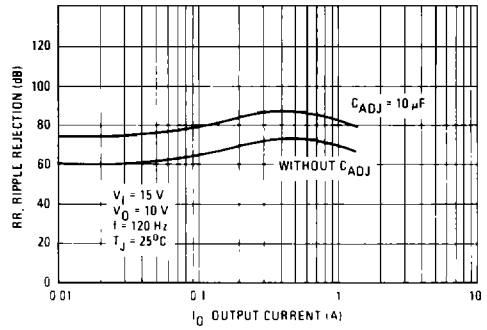

FIGURE 13 — RIPPLE REJECTION versus FREQUENCY

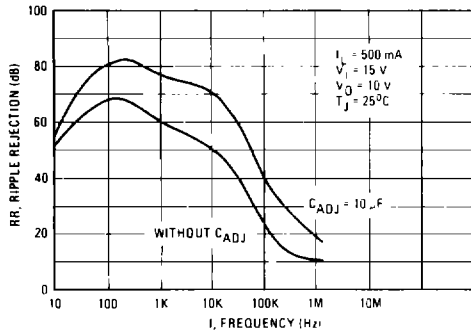

FIGURE 14 — OUTPUT IMPEDANCE

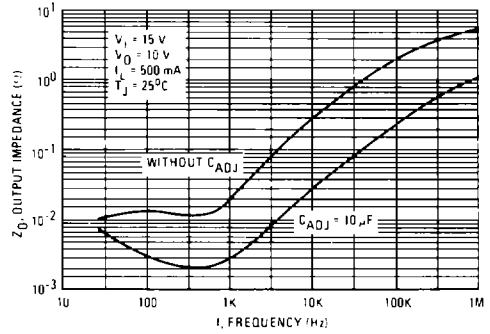

FIGURE 15 — LINE TRANSIENT RESPONSE

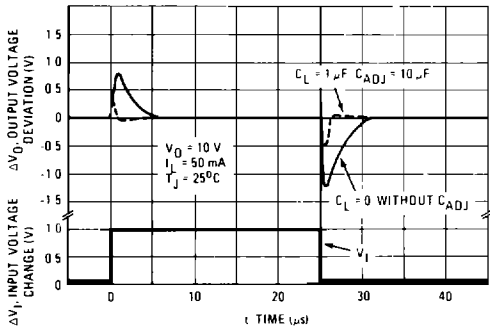
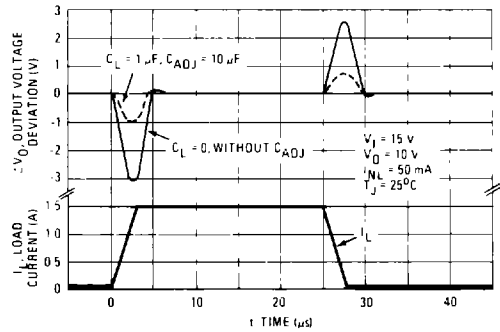

FIGURE 16 — LOAD TRANSIENT RESPONSE



LM117, LM217, LM317

APPLICATIONS INFORMATION

BASIC CIRCUIT OPERATION

The LM117 is a 3-terminal floating regulator. In operation, the LM117 develops and maintains a nominal 1.25 volt reference (V_{ref}) between its output and adjustment terminals. This reference voltage is converted to a programming current (I_{PRG}) by R_1 (see Figure 17), and this constant current flows through R_2 to ground. The regulated output voltage is given by:

$$V_{out} = V_{ref} \left(1 + \frac{R_2}{R_1} \right) + I_{Adj} R_2$$

Since the current from the adjustment terminal (I_{Adj}) represents an error term in the equation, the LM117 was designed to control I_{Adj} to less than 100 μA and keep it constant. To do this, all quiescent operating current is returned to the output terminal. This imposes the requirement for a minimum load current. If the load current is less than this minimum, the output voltage will rise.

Since the LM117 is a floating regulator, it is only the voltage differential across the circuit which is important to performance, and operation at high voltages with respect to ground is possible.

FIGURE 17 – BASIC CIRCUIT CONFIGURATION

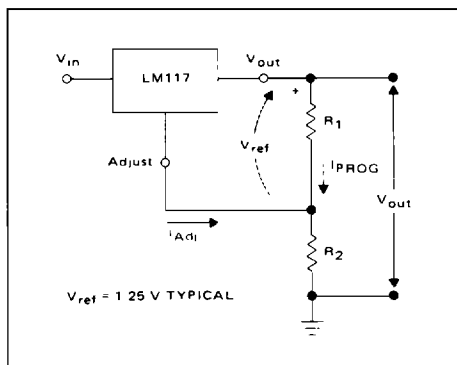

LOAD REGULATION

The LM117 is capable of providing extremely good load regulation, but a few precautions are needed to obtain maximum performance. For best performance, the programming resistor (R_1) should be connected as close to the regulator as possible to minimize line drops which effectively appear in series with the reference, thereby degrading regulation. The ground end of R_2 can be returned near the load ground to provide remote ground sensing and improve load regulation.

EXTERNAL CAPACITORS

A 0.1 μF disc or 1 μF tantalum input bypass capacitor (C_{in}) is recommended to reduce the sensitivity to input line impedance.

The adjustment terminal may be bypassed to ground to improve ripple rejection. This capacitor (C_{ADJ}) prevents ripple from being amplified as the output voltage is increased. A 10 μF capacitor should improve ripple rejection about 15dB at 120 Hz in a 10 volt application.

Although the LM117 is stable with no output capacitance, like any feedback circuit, certain values of external capacitance can cause excessive ringing. An output capacitance (C_O) in the form of a 1 μF tantalum or 25 μF aluminum electrolytic capacitor on the output swamps this effect and insures stability.

PROTECTION DIODES

When external capacitors are used with any I.C. regulator it is sometimes necessary to add protection diodes to prevent the capacitors from discharging through low current points into the regulator.

Figure 18 shows the LM117 with the recommended protection diodes for output voltages in excess of 25 V or high capacitance values ($C_O > 25 \mu F$, $C_{ADJ} > 10 \mu F$). Diode D_1 prevents C_O from discharging thru the I.C. during an input short circuit. Diode D_2 protects against capacitor C_{ADJ} discharging through the I.C. during an output short circuit. The combination of diodes D_1 and D_2 prevents C_{ADJ} from discharging through the I.C. during an input short circuit.

FIGURE 18 – VOLTAGE REGULATOR WITH PROTECTION DIODES

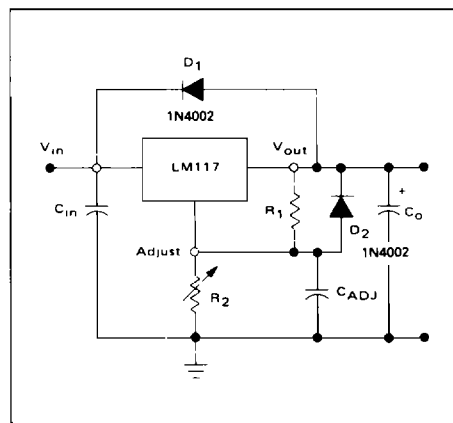

LM117, LM217, LM317

FIGURE 19 — "LABORATORY" POWER SUPPLY WITH ADJUSTABLE CURRENT LIMIT AND OUTPUT VOLTAGE

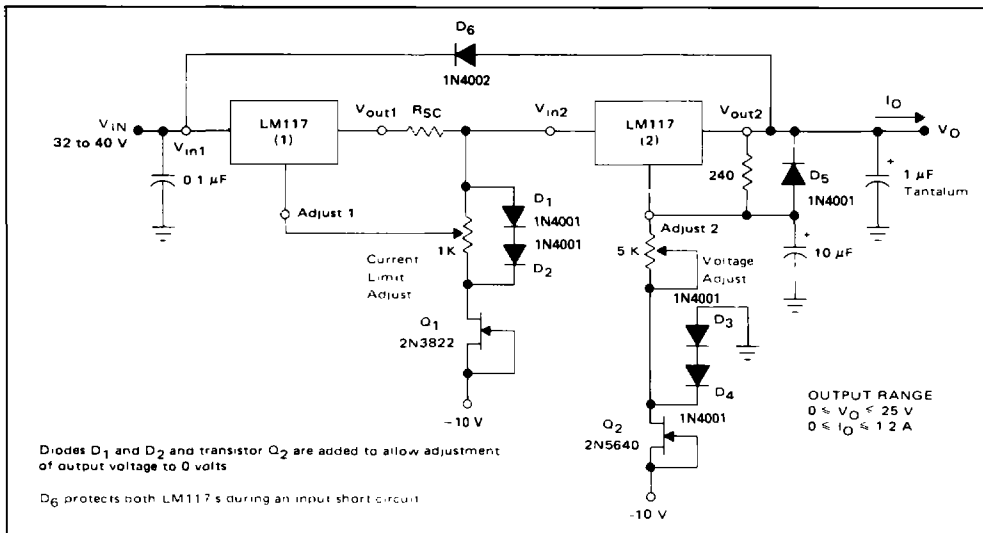

FIGURE 20 — ADJUSTABLE CURRENT LIMITER

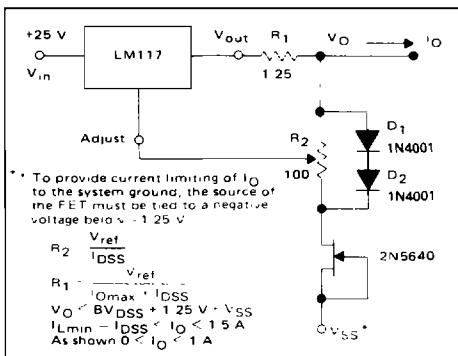

FIGURE 22 — SLOW TURN-ON REGULATOR

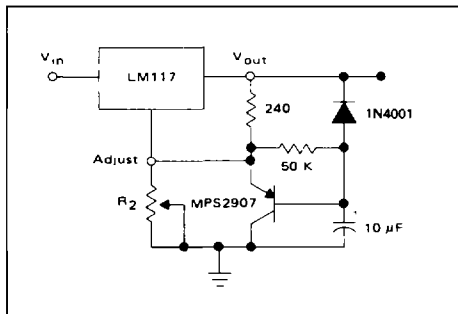

FIGURE 21 — 5 V ELECTRONIC SHUT DOWN REGULATOR

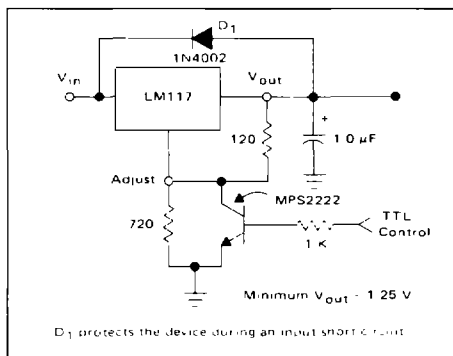

FIGURE 23 — CURRENT REGULATOR

