

OUTLINE

The R3111 series are CMOS-based voltage detector ICs with high detector threshold accuracy and ultra-low supply current, which can be operated at an extremely low voltage and is used for system reset as an example.

Each of these ICs consists of a voltage reference unit, a comparator, resistors for detector threshold setting, an output driver and a hysteresis circuit. The detector threshold is fixed with high accuracy internally and does not require any adjustment.

Three output types, Nch open drain type and CMOS type are available.

The R3111 Series are operable at a lower voltage than that for the RX5VL series, and can be driven by a single battery.

Six types of packages, TO-92, SOT-89, SOT-23-3, SOT-23-5, SC-82AB, and SON1612-6 are available.

FEATURES

- Ultra-low Supply Current Typ. 0.8 μ A ($V_{DD}=1.5V$)
- Wide Range of Operating Voltage..... 0.7V to 10.0V ($T_{opt}=25^{\circ}C$)
- Detector Threshold Stepwise setting with a step of 0.1V in the range of 0.9V to 6.0V is possible.
- High Accuracy Detector Threshold..... $\pm 2.0\%$
- Low Temperature-Drift Coefficient of Detector Threshold Typ. $\pm 100ppm/^{\circ}C$
- Two Output Types Nch Open Drain and CMOS
- Six Types of Packages TO-92, SOT-89(Mini-power Mold), SOT-23-3, SOT-23-5 (Mini-mold), SC-82AB, SON1612-6

APPLICATIONS

- CPU and Logic Circuit Reset
- Battery Checker
- Window Comparator
- Wave Shaping Circuit
- Battery Back-up Circuit
- Power Failure Detector

BLOCK DIAGRAMS

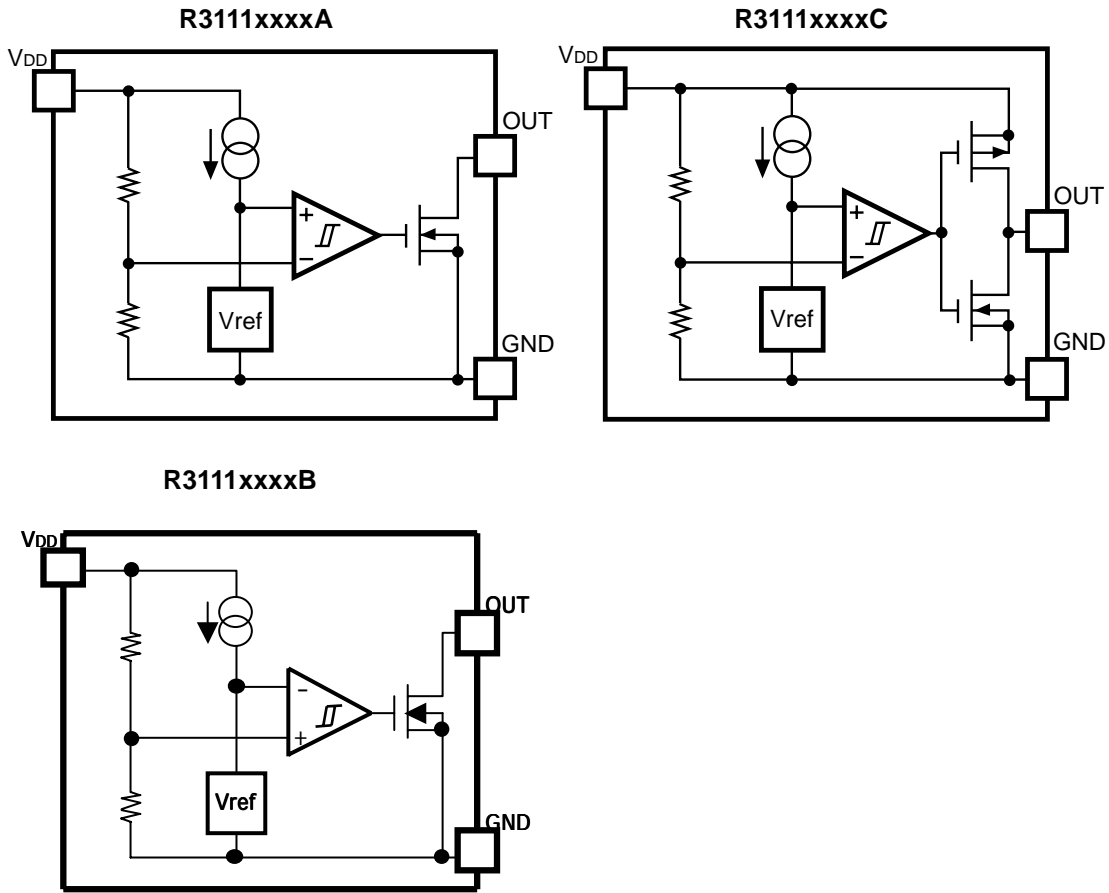

TIMING CHART

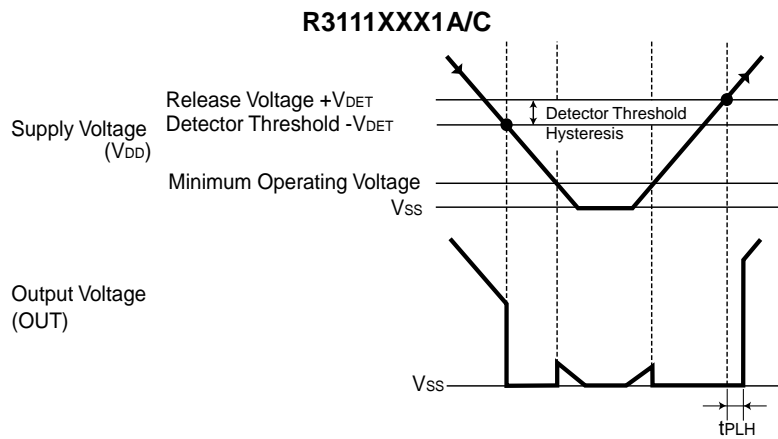

R3111XXX1B

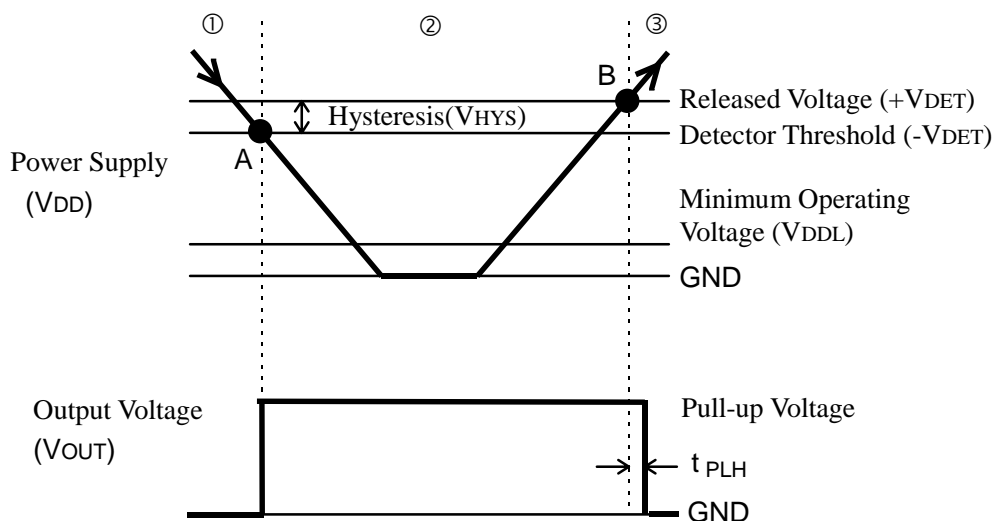

DEFINITION OF OUTPUT DELAY TIME

Output Delay Time t_{PLH}/t_{PHL} is defined as follows:

1. In the case of Nch Open Drain Output:(R3111XXXXA/B)

Under the condition of the output pin (OUT) is pulled up through a resistor of 470k Ω to 5V, the time interval between the rising edge of V_{DD} pulse from 0.7V to $(+V_{DET})+ 2.0V$ and becoming of the output voltage to 2.5V.

2. In the case of CMOS Output:(R3111XXXXC)

The time interval between the rising edge of V_{DD} pulse from 0.7V to $(+V_{DET})+ 2.0V$ and becoming of the output voltage to $(V_{DD}/2)$ V.

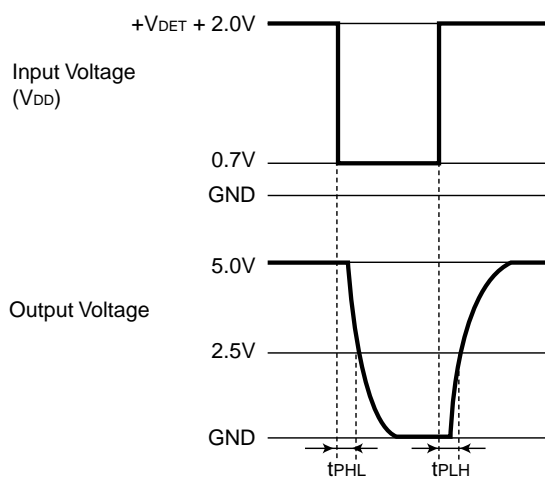

Nch Open Drain Output(R3111XXXXA)

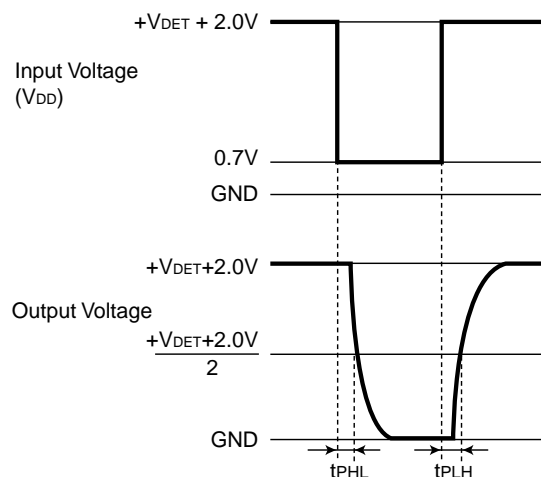

CMOS Output(R3111XXXXC)

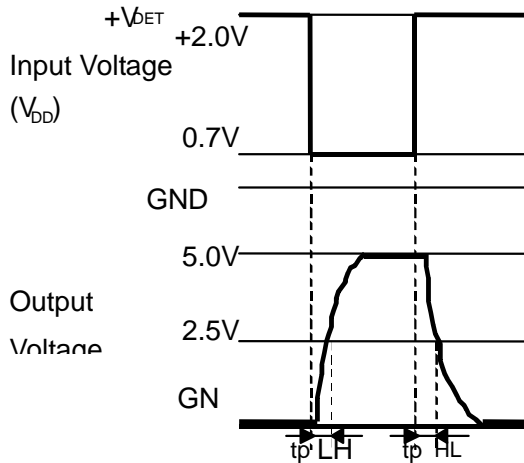

Nch Open Drain Output (R3111XXXXB)

SELECTION GUIDE

The package type, the detector threshold, the output type and the taping type of R3111 Series can be designated at the users' request by specifying the part number as follows;

R3111xxxxx-xx ←Part Number
 ↑ ↑ ↑ ↑ ↑
 a b c d e

Code	Descriptions
a	Designation of Package Type; E: TO-92 Q: SC-82AB H: SOT-89 N: SOT-23-5 / SOT-23-3 D: SON1612-6
b	Setting Detector Threshold (-V _{DET}); Stepwise setting with a step of 0.1V in the range of 0.9V to 6.0V is possible.
c	Designation of Package Type 1: except SOT-23-3 2: SOT-23-3
d	Designation of Output Type; A: Nch Open Drain(Output "L" at V _{DD} =-V _{det}) B: Nch Open Drain(Output "H" at V _{DD} =-V _{det}) C: CMOS (Output "L" at V _{DD} =-V _{det})
e	Designation of Packing or Taping Type; Ex.TO-92: TZ, SOT-89: T1, SOT-23-3, SOT-23-5, SC-82AB, SON1612-6: TR prescribed as standard directions. (Refer to Taping Specifications.) Antistatic bag for samples: C

PIN CONFIGURATION

● TO-92

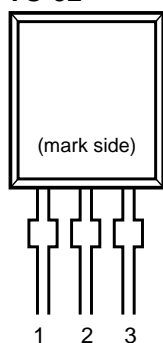

● SOT-89

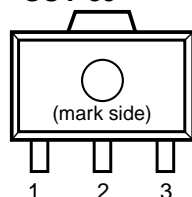

● SOT-23-3

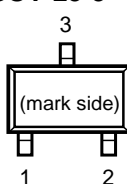

● SOT-23-5

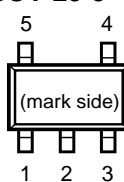

● SC-82AB

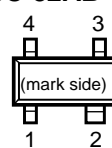

● SON1612-6



PIN DESCRIPTION

● TO-92

Pin No.	Symbol
1	V_{DD}
2	GND
3	OUT

● SOT-89

Pin No.	Symbol
1	OUT
2	V_{DD}
3	GND

● SOT-23-3

Pin No.	Symbol
1	OUT
2	GND
3	V_{DD}

● SOT-23-5

Pin No.	Symbol
1	OUT
2	V_{DD}
3	GND
4	NC
5	NC

● SC-82AB

Pin No.	Symbol
1	OUT
2	V_{DD}
3	NC
4	GND

● SON1612-6

Pin No.	Symbol
1	OUT
2	V_{DD}
3	GND
4	NC
5	V_{DD}
6	NC

ABSOLUTE MAXIMUM RATINGS

Symbol	Item	Rating	Unit
V_{DD}	Supply Voltage	12	V
V_{OUT1}	Output Voltage (CMOS)	$V_{SS}-0.3$ to $V_{DD}+0.3$	V
V_{OUT2}	Output Voltage (Nch)	$V_{SS}-0.3$ to 12	V
I_{OUT}	Output Current	70	mA
P_D	Power Dissipation 1 ^{*Note1}	300	mW
P_D	Power Dissipation 2 ^{*Note2}	150	mW
P_D	Power Dissipation 3 ^{*Note3}	500	mW
T_{opt}	Operating Temperature Range	-40 to 85	°C
T_{stg}	Storage Temperature Range	-55 to 125	°C
T_{solder}	Lead temperature (Soldering)	260°C, 10s	

*Note 1: applied to SOT-89 and TO-92 Single suspended in the air

*Note 2: applied to SOT-23-3, SOT-23-5 and SC-82AB Single suspended in the air

*Note 3: applied to SON1612-6 at mounted on board

P_D depends on conditions of mounting on board. This specification is based on the measurement at the condition below:

*Measurement Conditions

Environment: Mounted on board (Wind velocity 0m/s)

Board Material: FR-4 (2-layer)

Board dimensions : 40mm x 40mm x t1.6mm

Copper Area: 50%

ELECTRICAL CHARACTERISTICS

R3111x09xA/C

 $T_{opt}=25^{\circ}\text{C}$

Symbol	Item	Conditions	Min.	Typ.	Max.	Unit
$-V_{DET}$	Detector Threshold		0.882	0.900	0.918	V
V_{HYS}	Detector Threshold Hysteresis		0.027	0.045	0.063	V
I_{SS}	Supply Current	$V_{DD}= 0.80\text{V}$ 2.90V		0.8 0.9	2.4 2.7	μA
V_{DDH}	Maximum Operating Voltage				10	V
V_{DDL}	Minimum Operating Voltage ^{*Note1}	$T_{opt}=25^{\circ}\text{C}$		0.55	0.70	V
		$-40^{\circ}\text{C} \leq T_{opt} \leq 85^{\circ}\text{C}$		0.65	0.80	
I_{OUT}	Output Current (Driver Output Pin)	Nch $V_{DS}=0.05\text{V}, V_{DD}=0.70\text{V}$ $V_{DS}=0.50\text{V}, V_{DD}=0.85\text{V}$	0.01 0.05	0.05 0.50		mA
		Pch $V_{DS}=-2.1\text{V}, V_{DD}=4.5\text{V}$	1.0	2.0		mA
t_{PLH}	Output Delay Time ^{*Note2}				100	μs
$\Delta-V_{DET}/\Delta T$	Detector Threshold Temperature Coefficient	$-40^{\circ}\text{C} \leq T_{opt} \leq 85^{\circ}\text{C}$		± 100		ppm/°C

R3111x18xA/C

T_{opt}=25°C

Symbol	Item	Conditions	Min.	Typ.	Max.	Unit
-V _{DET}	Detector Threshold		1.764	1.800	1.836	V
V _{HYS}	Detector Threshold Hysteresis		0.054	0.090	0.126	V
I _{SS}	Supply Current	V _{DD} = 1.70V 3.80V		0.8 1.0	2.4 3.0	μA
V _{DDH}	Maximum Operating Voltage				10	V
V _{DDL}	Minimum Operating Voltage ^{*Note1}	T _{opt} =25°C		0.55	0.70	V
		-40°C ≤ T _{opt} ≤ 85°C		0.65	0.80	
I _{OUT}	Output Current (Driver Output Pin)	Nch V _{DS} =0.05V, V _{DD} =0.70V V _{DS} =0.50V, V _{DD} =0.85V	0.01 1.00	0.05 2.00		mA
		Pch V _{DS} =-2.1V, V _{DD} =4.5V	1.0	2.0		
t _{PLH}	Output Delay Time ^{*Note2}				100	μs
Δ-V _{DET} /ΔT	Detector Threshold Temperature Coefficient	-40°C ≤ T _{opt} ≤ 85°C		±100		ppm/°C

R3111x27xA/C

T_{opt}=25°C

Symbol	Item	Conditions	Min.	Typ.	Max.	Unit
-V _{DET}	Detector Threshold		2.646	2.700	2.754	V
V _{HYS}	Detector Threshold Hysteresis		0.081	0.135	0.189	V
I _{SS}	Supply Current	V _{DD} = 2.60V 4.70V		0.9 1.1	2.7 3.3	μA
V _{DDH}	Maximum Operating Voltage				10	V
V _{DDL}	Minimum Operating Voltage ^{*Note1}	T _{opt} =25°C		0.55	0.70	V
		-40°C ≤ T _{opt} ≤ 85°C		0.65	0.80	
I _{OUT}	Output Current (Driver Output Pin)	Nch V _{DS} =0.05V, V _{DD} =0.70V V _{DS} =0.50V, V _{DD} =1.50V	0.01 1.00	0.05 2.00		mA
		Pch V _{DS} =-2.1V, V _{DD} =4.5V	1.0	2.0		
t _{PLH}	Output Delay Time ^{*Note2}				100	μs
Δ-V _{DET} /ΔT	Detector Threshold Temperature Coefficient	-40°C ≤ T _{opt} ≤ 85°C		±100		ppm/°C

R3111x**R3111x36xA/C**T_{opt}=25°C

Symbol	Item	Conditions	Min.	Typ.	Max.	Unit
-V _{DET}	Detector Threshold		3.528	3.600	3.672	V
V _{HYS}	Detector Threshold Hysteresis		0.108	0.180	0.252	V
I _{SS}	Supply Current	V _{DD} = 3.47V 5.60V		1.0 1.2	3.0 3.6	μA
V _{DDH}	Maximum Operating Voltage				10	V
V _{DDL}	Minimum Operating Voltage ^{*Note1}	T _{opt} =25°C		0.55	0.70	V
		-40°C ≤ T _{opt} ≤ 85°C		0.65	0.80	
I _{OUT}	Output Current (Driver Output Pin)	Nch V _{DS} =0.05V, V _{DD} =0.70V V _{DS} =0.50V, V _{DD} =1.50V	0.01 1.00	0.05 2.00		mA
		Pch V _{DS} =-2.1V, V _{DD} =4.5V	1.0	2.0		
t _{PLH}	Output Delay Time ^{*Note2}				100	μs
Δ-V _{DET} /ΔT	Detector Threshold Temperature Coefficient	-40°C ≤ T _{opt} ≤ 85°C		±100		ppm/°C

R3111x45xA/CT_{opt}=25°C

Symbol	Item	Conditions	Min.	Typ.	Max.	Unit
-V _{DET}	Detector Threshold		4.410	4.500	4.590	V
V _{HYS}	Detector Threshold Hysteresis		0.135	0.225	0.315	V
I _{SS}	Supply Current	V _{DD} = 4.34V 6.50V		1.1 1.3	3.3 3.9	μA
V _{DDH}	Maximum Operating Voltage				10	V
V _{DDL}	Minimum Operating Voltage ^{*Note1}	T _{opt} =25°C		0.55	0.70	V
		-40°C ≤ T _{opt} ≤ 85°C		0.65	0.80	
I _{OUT}	Output Current (Driver Output Pin)	Nch V _{DS} =0.05V, V _{DD} =0.70V V _{DS} =0.50V, V _{DD} =1.50V	0.01 1.00	0.05 2.00		mA
		Pch V _{DS} =-2.1V, V _{DD} =8.0V	1.5	3.0		
t _{PLH}	Output Delay Time ^{*Note2}				100	μs
Δ-V _{DET} /ΔT	Detector Threshold Temperature Coefficient	-40°C ≤ T _{opt} ≤ 85°C		±100		ppm/°C

R3111x54xA/C

T_{opt}=25°C

Symbol	Item	Conditions	Min.	Typ.	Max.	Unit
-V _{DET}	Detector Threshold		5.292	5.400	5.508	V
V _{HYS}	Detector Threshold Hysteresis		0.162	0.270	0.378	V
I _{SS}	Supply Current	V _{DD} = 5.20V 7.40V		1.2 1.4	3.6 4.2	μA
V _{DDH}	Maximum Operating Voltage				10	V
V _{DDL}	Minimum Operating Voltage ^{*Note1}	T _{opt} =25°C		0.55	0.70	V
		-40°C ≤ T _{opt} ≤ 85°C		0.65	0.80	
I _{OUT}	Output Current (Driver Output Pin)	Nch V _{DS} =0.05V, V _{DD} =0.70V V _{DS} =0.50V, V _{DD} =1.50V	0.01 1.00	0.05 2.00		mA
		Pch V _{DS} =-2.1V, V _{DD} =8.0V	1.5	3.0		
t _{PLH}	Output Delay Time ^{*Note2}				100	μs
Δ-V _{DET} /ΔT	Detector Threshold Temperature Coefficient	-40°C ≤ T _{opt} ≤ 85°C		±100		ppm/°C

*Note1: Minimum operating voltage means the value of input voltage when output voltage maintains 0.1V or less. (In the case of Nch Open Drain Output type, the output pin is pulled up with a resistance of 470kΩ to 5.0V.)

*Note2: In the case of CMOS Output type: The time interval between the rising edge of V_{DD} input pulse from 0.7V to (+V_{DET})+2.0V and output voltage level becoming to V_{DD}/2.

In the case of Nch Open Drain Output type: the output pin is pulled up with a resistance of 470kΩ to 5.0V, The time interval between the rising edge of V_{DD} input pulse from 0.7V to (+V_{DET})+2.0V and output voltage level becoming to 2.5V.

R3111Q231B

T_{opt}=25°C

Symbol	Item	Conditions	Min.	Typ.	Max.	Unit
-V _{DET}	Detector Threshold		2.254	2.300	2.346	V
V _{HYS}	Detector Threshold Hysteresis		0.069	0.115	0.161	V
I _{SS}	Supply Current	V _{DD} =2.20V 4.30V		0.9 1.1	2.7 3.3	μA
V _{DDH}	Maximum Operating Voltage				10	V
V _{DDL}	Minimum Operating Voltage ^{*Note1}	T _{opt} =25°C		0.55	0.70	V
		-40°C ≤ T _{opt} ≤ 85°C		0.65	0.80	
I _{OUT}	Output Current (Driver Output Pin)	Nch V _{DS} =0.50V, V _{DD} =3.00V		10		mA
PLH	Output Delay Time ^{*Note2}				100	
Δ-V _{DET} /ΔT	Detector Threshold Temperature Coefficient	-40°C ≤ T _{opt} ≤ 85°C		±100		ppm/°C

R3111Q441B

T_{opt}=25°C

Symbol	Item	Conditions	Min.	Typ.	Max.	Unit
-V _{DET}	Detector Threshold		4.312	4.400	4.488	V
V _{HYS}	Detector Threshold Hysteresis		0.132	0.220	0.308	V
I _{SS}	Supply Current	V _{DD} = 4.24V 6.40V		1.1 1.3	3.3 3.9	μA
V _{DDH}	Maximum Operating Voltage				10	V
V _{DDL}	Minimum Operating Voltage ^{*Note1}	T _{opt} =25°C -40°C ≤ T _{opt} ≤ 85°C		0.55 0.65	0.70 0.80	V
I _{OUT}	Output Current (Driver Output Pin)	Nch V _{DS} =0.50V, V _{DD} =5.50V		18		mA
t _{PLH}	Output Delay Time ^{*Note2}				100	μs
Δ-V _{DET} /ΔT	Detector Threshold Temperature Coefficient	-40°C ≤ T _{opt} ≤ 85°C		±100		ppm/°C

*Note1: Minimum operating voltage means the value of input voltage when output voltage maintains 0.1V or less. (In the case of Nch Open Drain Output type, the output pin is pulled up with a resistance of 470kΩ to 5.0V.)

*Note2: In the case of CMOS Output type: The time interval between the rising edge of V_{DD} input pulse from 0.7V to (+V_{DET})+2.0V and output voltage level becoming to V_{DD}/2.

In the case of Nch Open Drain Output type: the output pin is pulled up with a resistance of 470kΩ to 5.0V, The time interval between the rising edge of V_{DD} input pulse from 0.7V to (+V_{DET})+2.0V and output voltage level becoming to 2.5V.

OPERATION

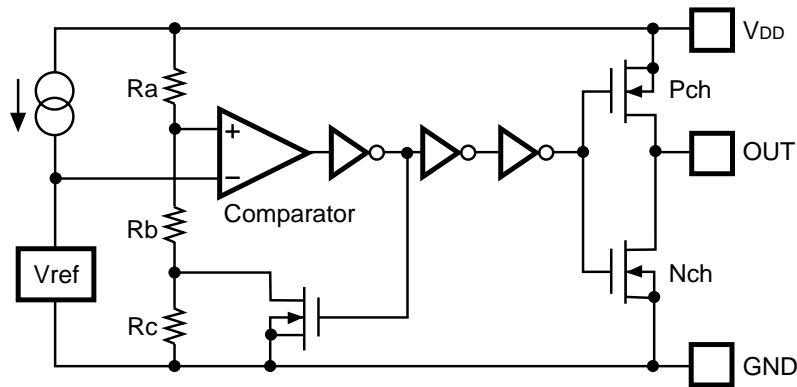

Figure 1. Block Diagram (R3111XXXXC)

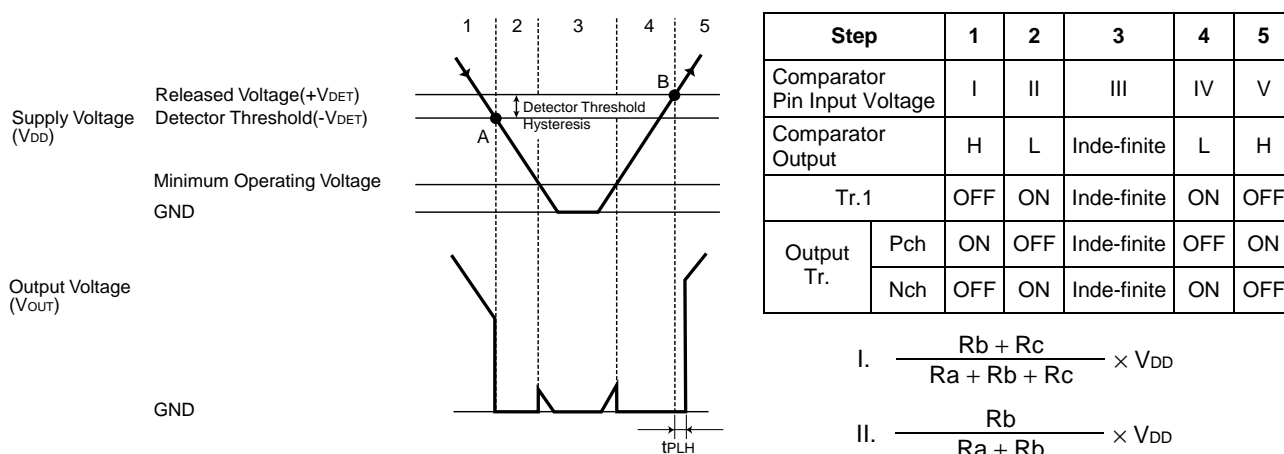

Figure 2. Operation Diagram

Step 1. The output voltage is equal to the supply voltage (V_{DD}).

Step 2. At Point "A", $V_{ref} \geq V_{DD} \times (Rb + Rc) / (Ra + Rb + Rc)$ is true, as a result, the output of comparator is reverse, and output voltage becomes to GND level. The voltage level of Point A means detector threshold voltage, or ($-V_{DET}$).

Step 3. When the supply voltage is less than minimum operating voltage, the operation of output transistor becomes indefinite, and in the case that output is pulled up to V_{DD} , the output voltage equals to V_{DD} voltage.

Step 4. The output voltage equals to GND level.

Step 5. At Point "B", $V_{ref} \geq V_{DD} \times Rb / (Ra + Rb)$ is true, Output of the comparator is reverse, and output voltage is equal to the supply voltage, or (V_{DD}). The voltage level of Point B means released voltage, or ($+V_{DET}$).

* The difference between released voltage and detector threshold voltage is the detector threshold hysteresis.

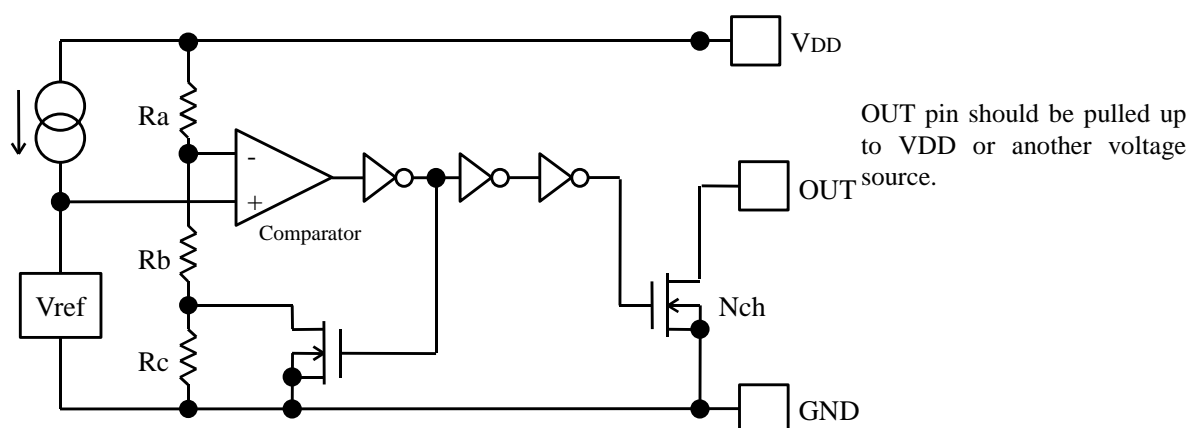
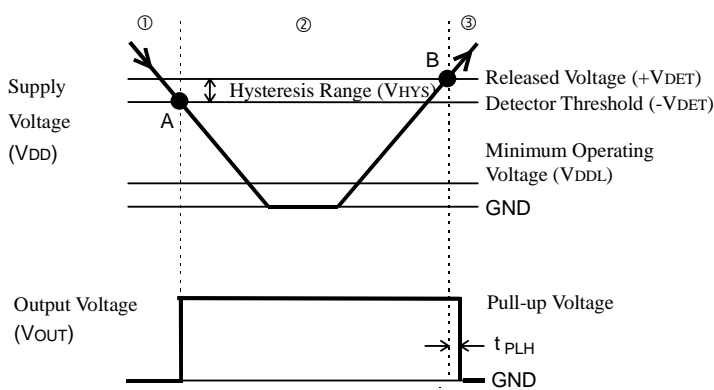

Figure 3. Block Diagram (R3111XXXXB)



Step	1	2	3	
Comparator Pin Input Voltage	I	II	III	
Comparator Output	H	L	H	
Tr.1	OFF	ON	OFF	
Output Tr.	Nch	ON	OFF	ON

$$I. \frac{R_b + R_c}{R_a + R_b + R_c} \times V_{DD}$$

$$II. \frac{R_b}{R_a + R_b} \times V_{DD}$$

Figure 4. Operation Diagram

Step 1. The output voltage is equal to the supply voltage (V_{DD}).

Step 2. At Point "A", $V_{ref} \geq V_{DD} \times (R_b + R_c) / (R_a + R_b + R_c)$ is true, as a result, the output of comparator is reverse, and output voltage becomes to Pull-up level. The voltage level of Point A means detector threshold voltage, or ($-V_{DET}$).

Step 3. At Point "B", $V_{ref} \geq V_{DD} \times R_b / (R_a + R_b)$ is true, Output of the comparator is reverse, and output voltage is equal to the GND after t_{PLH} . The voltage level of Point B means released voltage, or ($+V_{DET}$).

* The difference between released voltage and detector threshold voltage is the detector threshold hysteresis.

TEST CIRCUITS

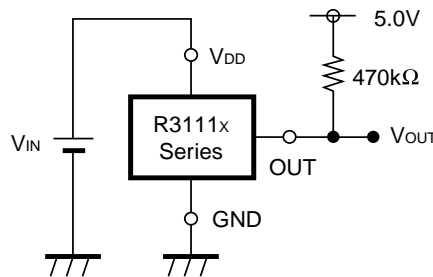
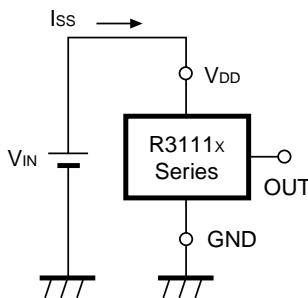

Pull-up circuit is not necessary for CMOS Output type, or R3111xxxxC.

Supply Current Test Circuit

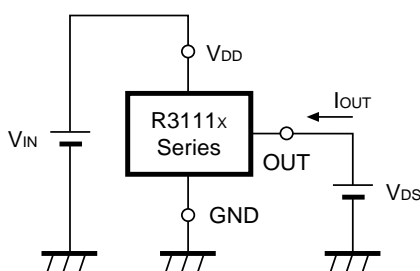

Detector Threshold Test Circuit

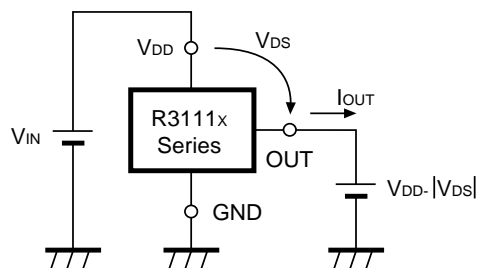

*Apply to CMOS Output type only

Nch Driver Output Current Test Circuit

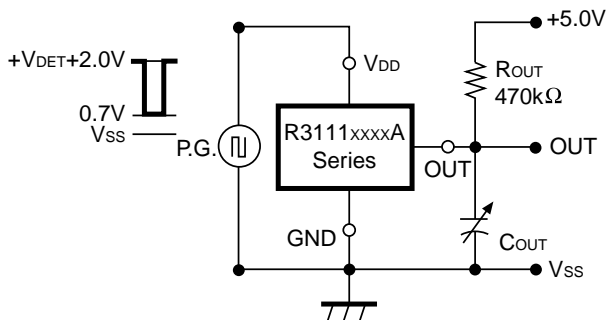

Output Delay Time Test Circuit (1)

Pch Driver Output Current Test Circuit

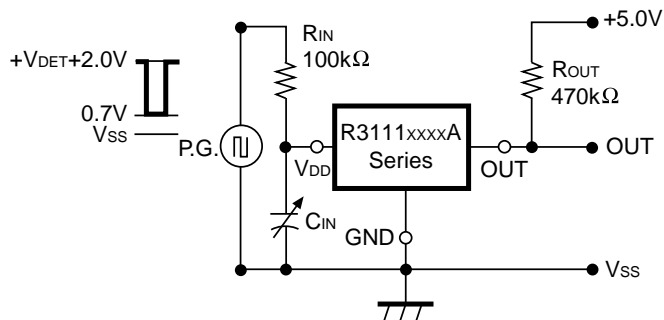

Output Delay Time Test Circuit (2)

TYPICAL CHARACTERISTICS

1) Supply Current vs. Input Voltage

R3111x09xC

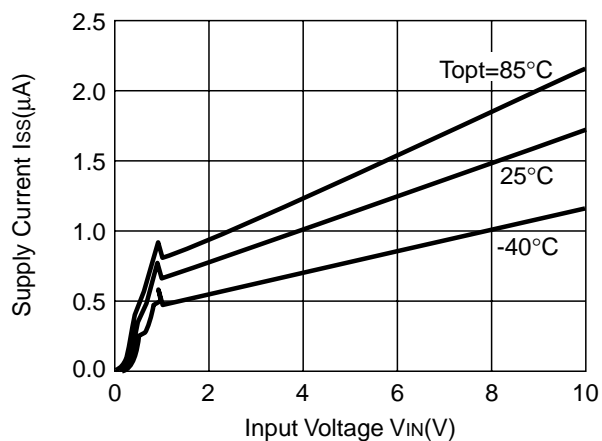

R3111x27xC

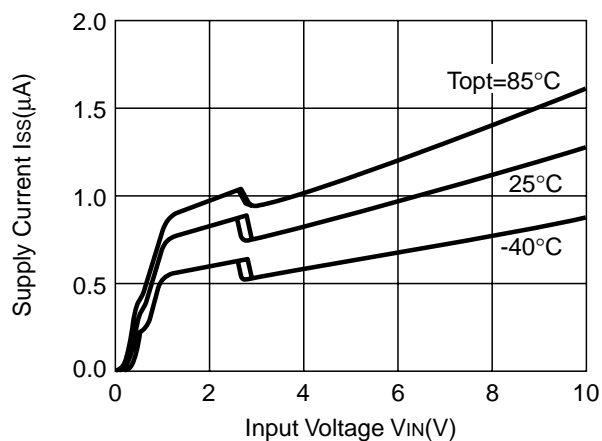

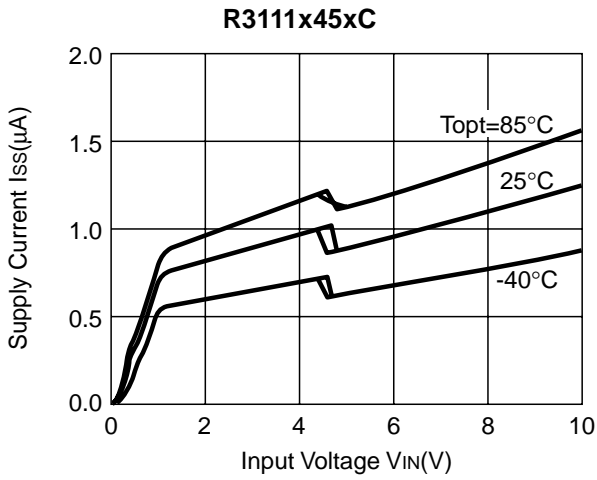

2) Detector Threshold Hysteresis vs. Temperature

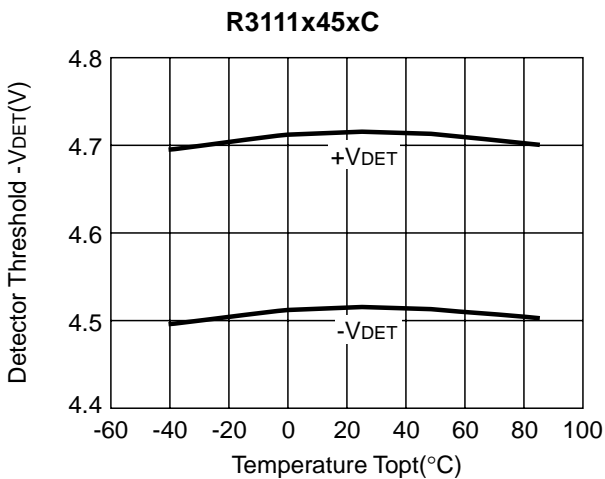
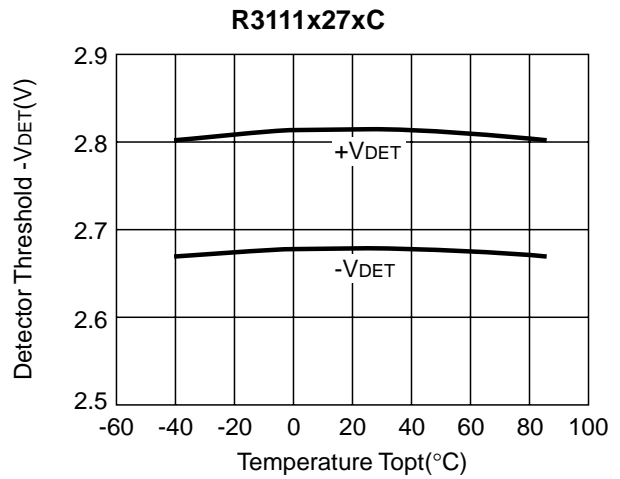
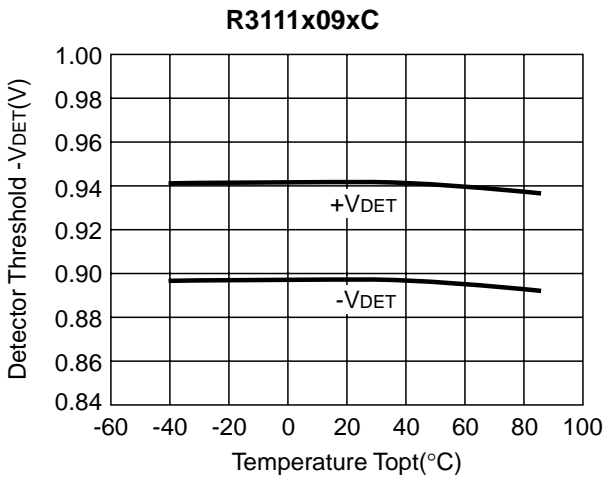

3) Output Voltage vs. Input Voltage

R3111x09xC

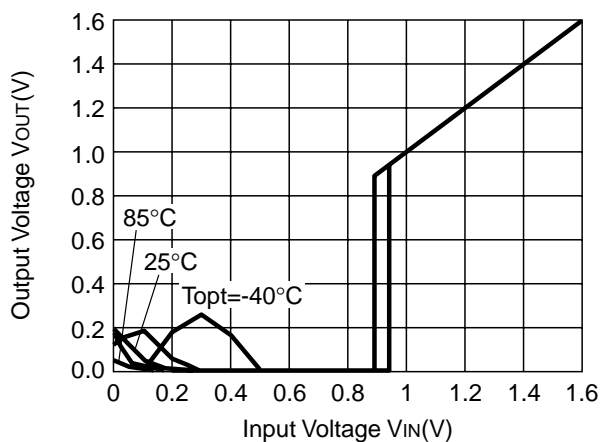

R3111x09xA

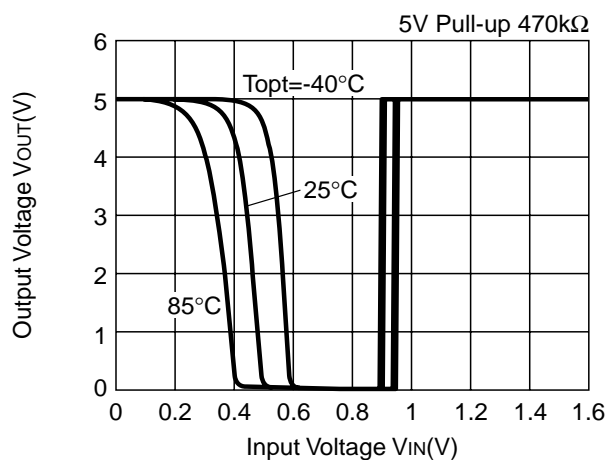

R3111x27xC

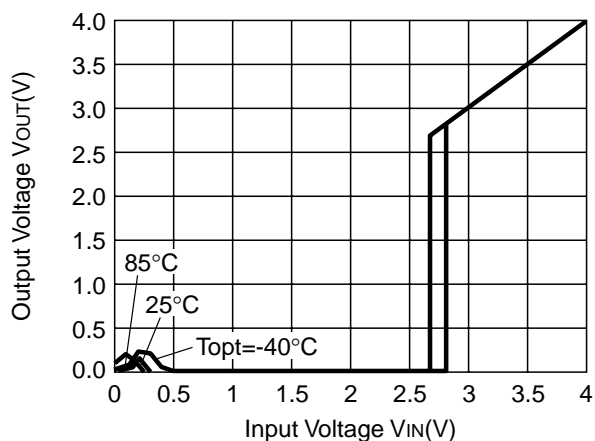

R3111x27xA

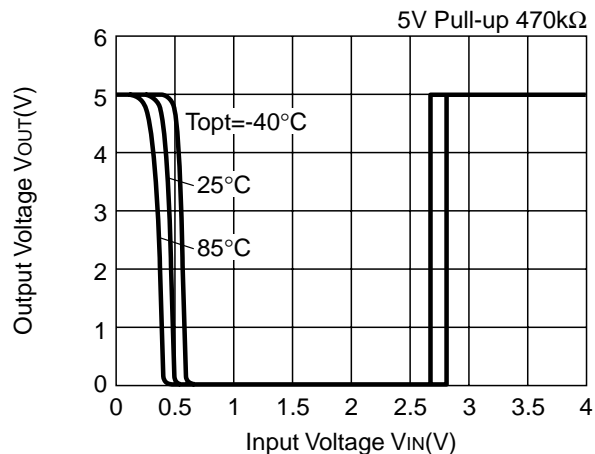

R3111x45xC

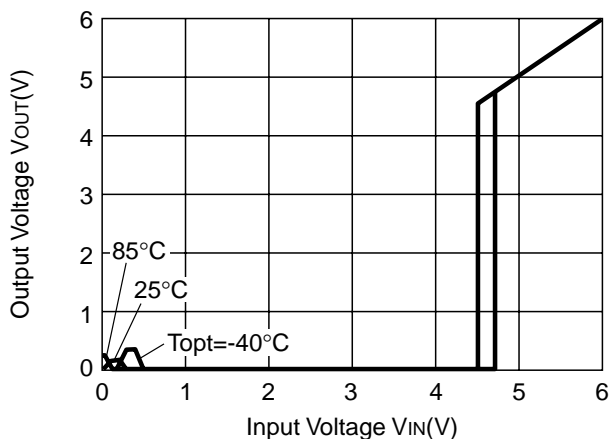

R3111x45xA

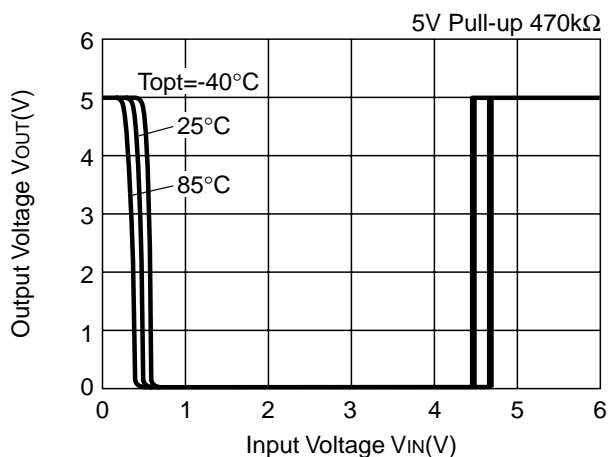

R3111x

4) Nch Driver Output Current vs. V_{DS}

R3111x09xC

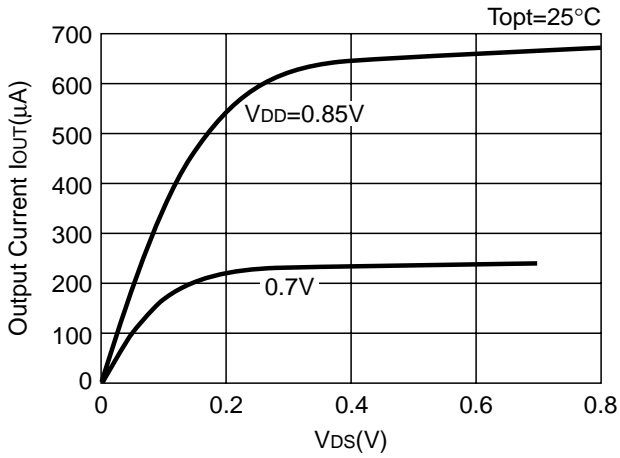

R3111x09xC

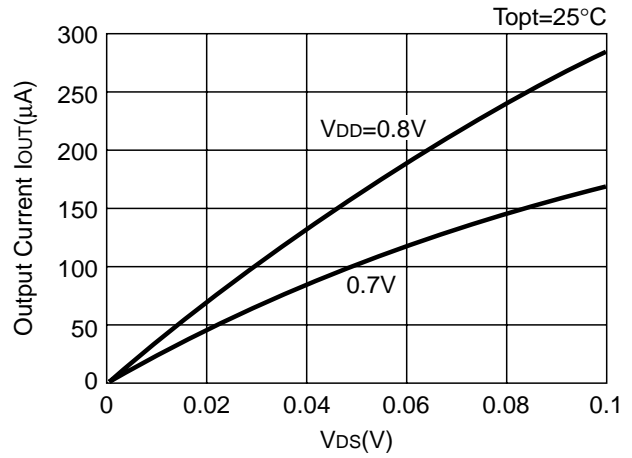

R3111x27xC

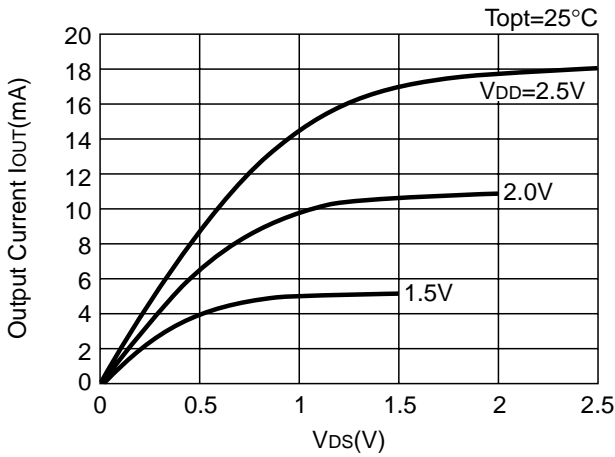

R3111x27xC

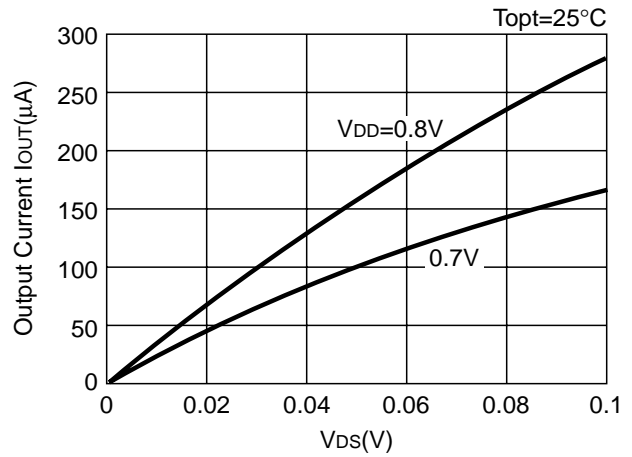

R3111x45xC

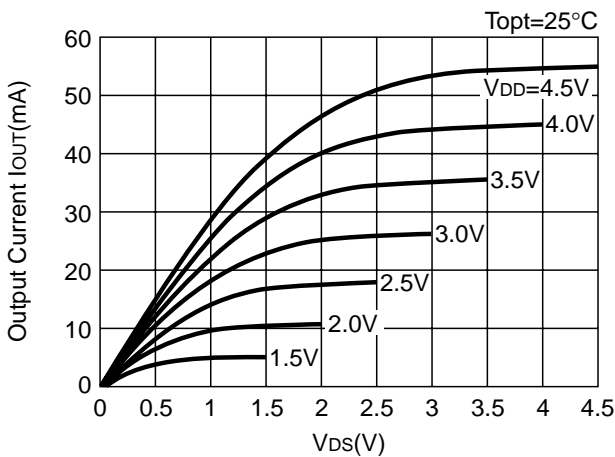

R3111x45xC

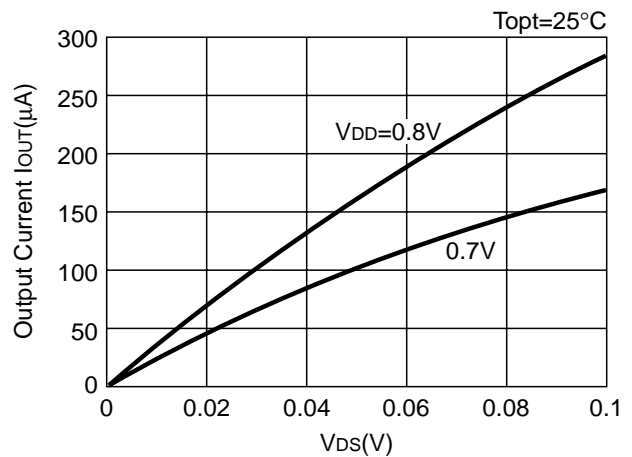

5) Nch Driver Output Current vs. Input Voltage

R3111x09xC

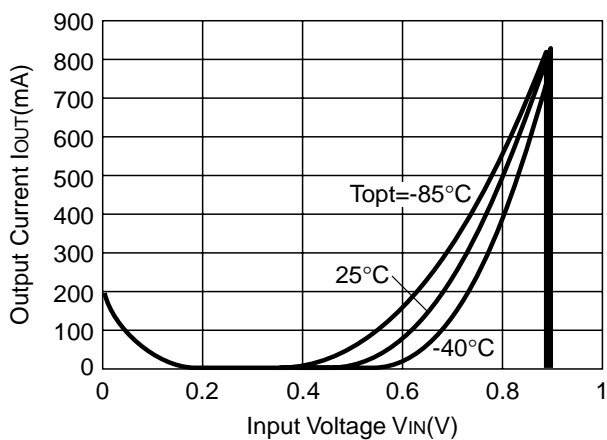

R3111x27xC

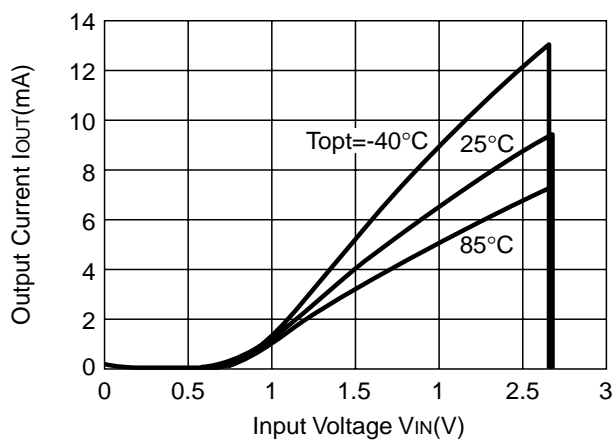

R3111x45xC

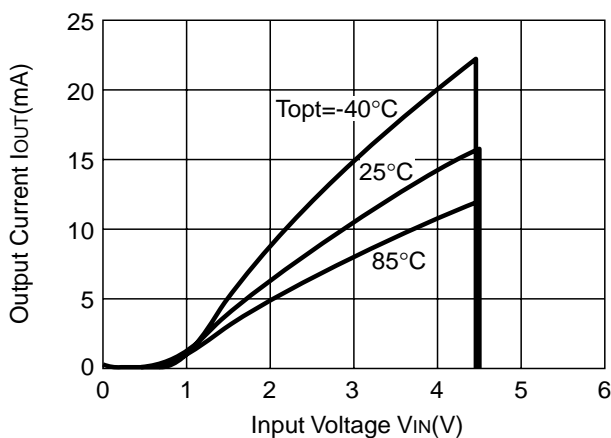

6) Pch Driver Output Current vs. Input Voltage

R3111x09xC

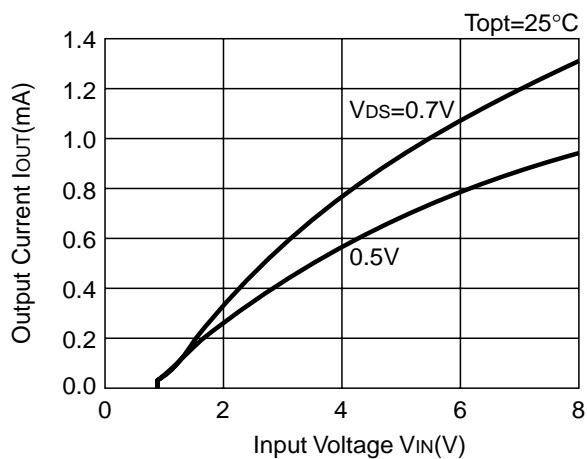

R3111x27xC

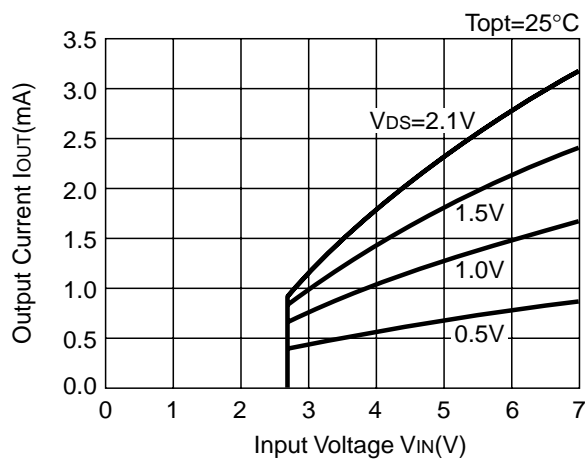

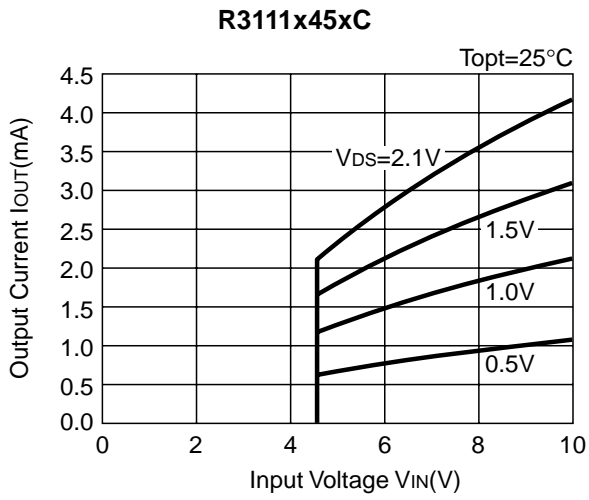

7) Output Delay Time vs. Load Capacitance

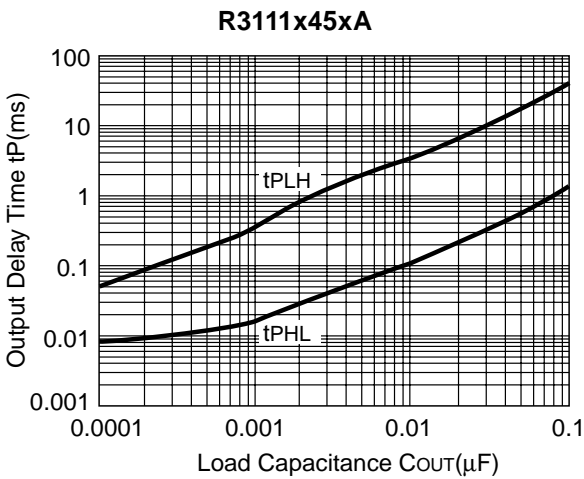
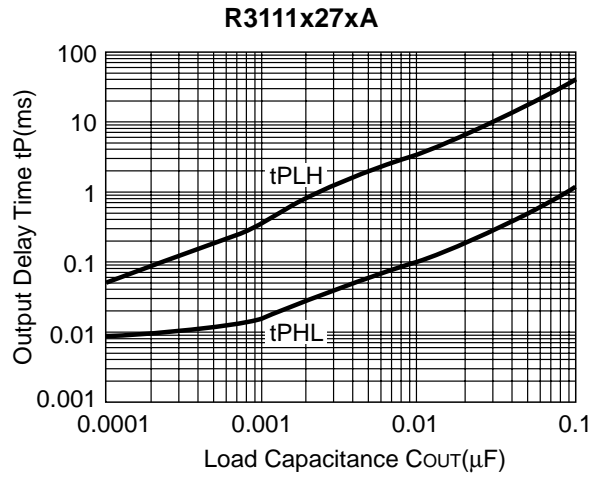
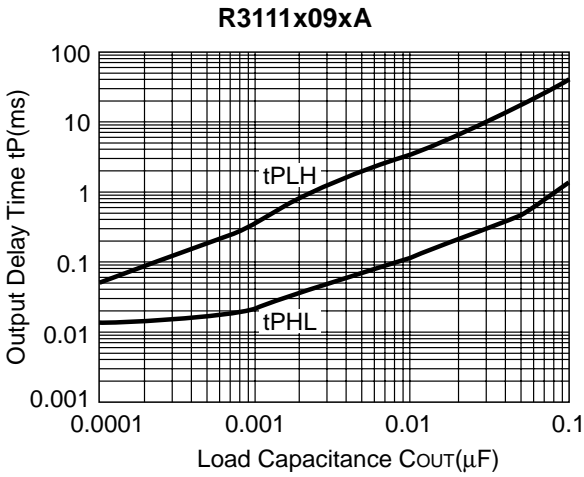

8) Output Delay Time vs. Input Pin Capacitance

R3111x09xA

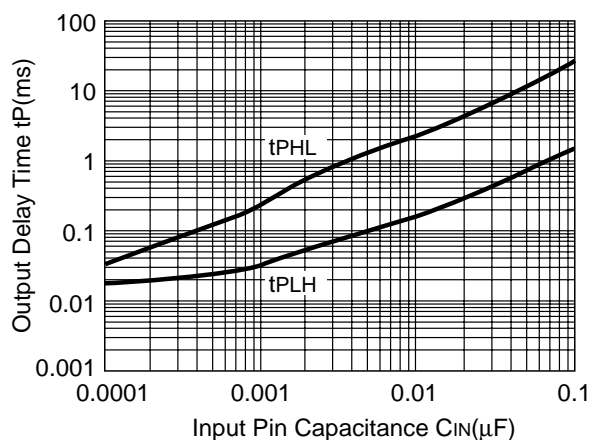

R3111x27xA

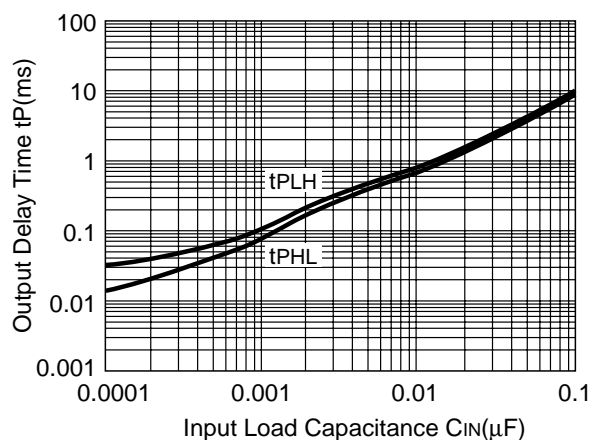

R3111x45xA

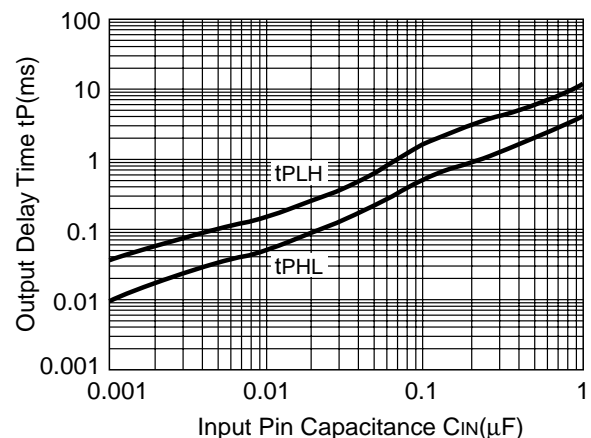

TYPICAL APPLICATIONS

R3111xxxxA CPU Reset Circuit (Nch Open Drain Output)

Case 1. Input Voltage to R3111xxxxA is equal to Input Voltage to CPU

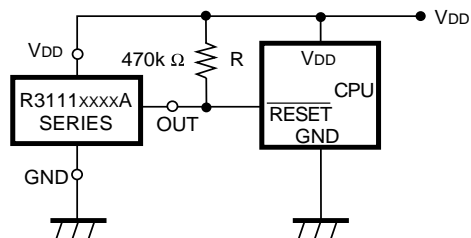

Case 2. Input Voltage to R3111xxxxA is unequal to Input Voltage to CPU

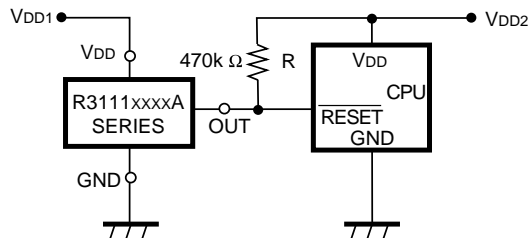

R3111x

R3111xxxxA CPU Reset Circuit CMOS Output

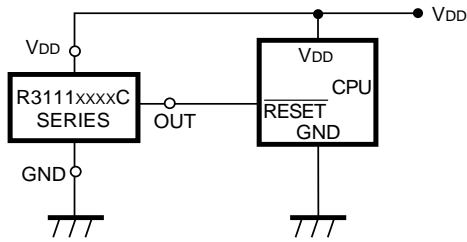

R3111xxxxA Output Delay Time Circuit 1 (Nch Open Drain Output)

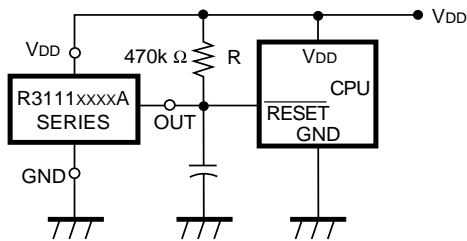

R3111xxxxA Output Delay Time Circuit 2 (Nch Open Drain Output)

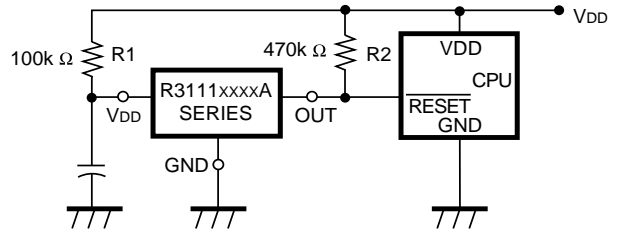

Memory Back-up Circuit

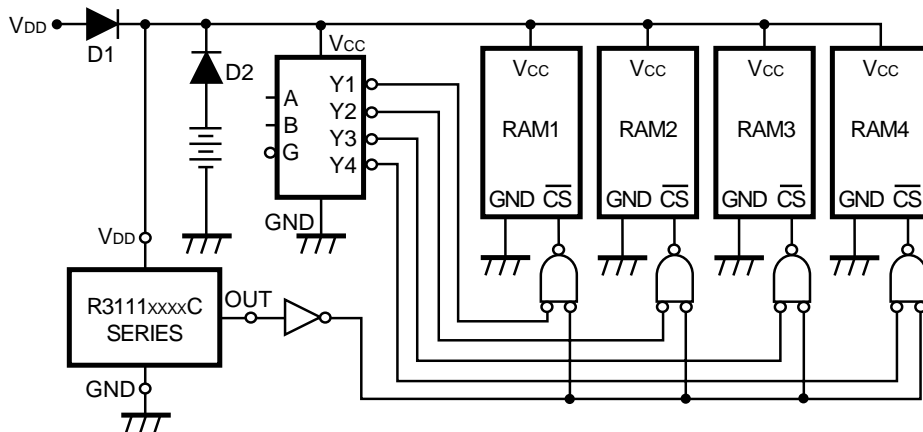

Voltage level Indicator Circuit (lighted when the power runs out) (Nch Open Drain Output)

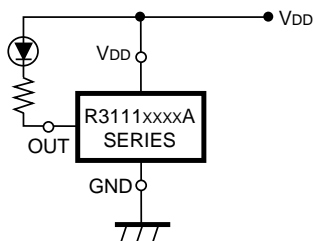

**Detector Threshold Adjustable Circuit
(Nch Open Drain Output)**

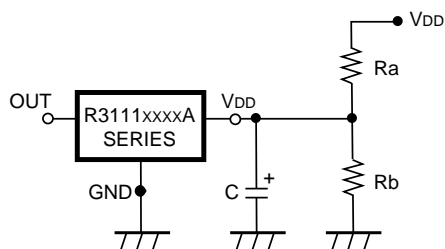

Adjusted Detector Threshold
 $= (-V_{DET}) * (Ra + Rb) / Rb$

Hysteresis Voltage
 $= (V_{HYS}) * (Ra + Rb) / Rb$

*) If the value of Ra is set excessively large, voltage drop may occur caused by the supply current of IC itself, and detector threshold may vary.

**Window Comparator Circuit
(Nch Open Drain Output)**

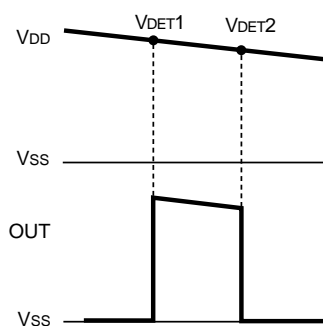
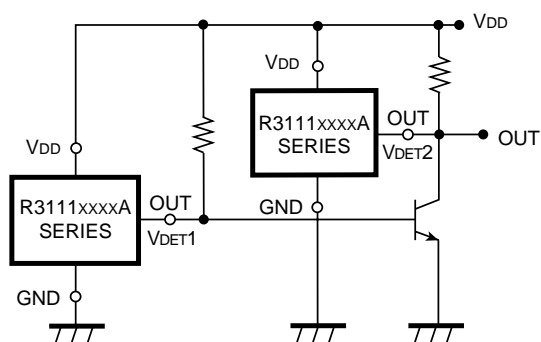

Over-charge Preventing Circuit

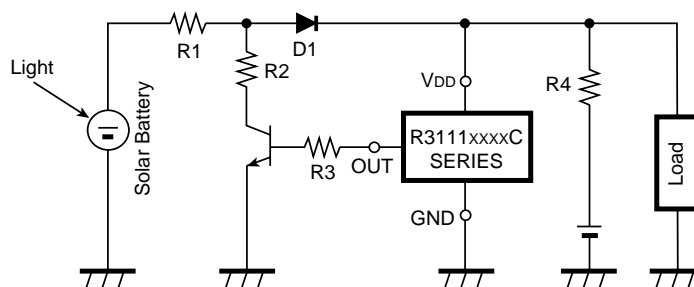

TECHNICAL NOTES

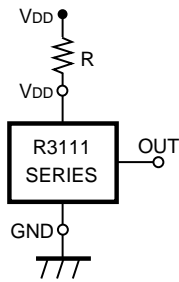

Figure 9

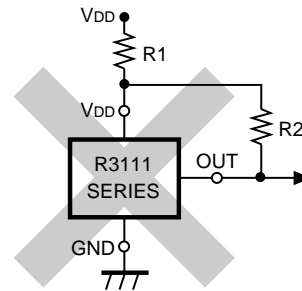

Figure 10

- In Figure 9, When R3111xxxxC is used, and if an impedance is connected between Voltage Supplier and the V_{DD} Pin of R3111xxxxC Series, the operation might be unstable by cross conduction current at detection.

When R3111xxxxA/B is used in Figure 9, if the value of R is set excessively large, voltage drop may occur caused by supply current of IC itself and Detector threshold may vary.
- Wiring as shown in Figure 10 may cause the oscillation in both output types of R3111 Series.