

MEGGITT SIGMA
AXIAL INDUCTORS
SMD INDUCTORS
THIN FILM PRINTED INDUCTORS
POWER CHOKES IN
RADIAL AND AXIAL STYLE

SMD Chip Inductor

TYPE 3612 SERIES

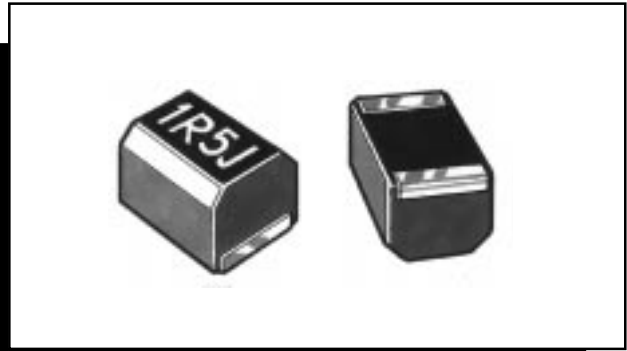

The 3612 series is a standard 12:10 moulded winding on ferrite, of particularly high quality and reliability. Packaged in reels of 2000 pieces these devices are used on automatic pick and place machines for high speed mounting. Wide solder coated intergrated terminals aid accurate placement. The 3612 series is offered in five versions, the M, L, S, T and P styles. The M is an economy version, the L offers low inductance values, the S is shielded whilst the T is the standard style. The P style is a recently introduced power version offering surprisingly high current carrying capability.

MEGGITT CITEC KEY FEATURES

- INDUCTANCE RANGE 0.01 μ H TO 470 μ H
 - SUITABLE FOR DIP AND WAVE SOLDER
 - SMALL SIZE - 3.2 x 2.5mm (1210)
 - TEMPERATURE RANGE -20°C to +100°C
 - TAPED TO IEC 286 Pt3
 - LABORATORY DESIGN KITS AVAILABLE
 - HIGH RELIABILITY
 - AVAILABLE FROM STOCK
-

ELECTRICAL - Style M (Economy)

Inductance Code	Inductance (μ H)	Tolerance (\pm %)	Q Min	LQ Test Freq. (MHz)	Rdc Max (Ω)	S.R.F. (MHz)	Idc (mA) Max
R22	0.22	10	25	25.2	0.29	230	360
R27	0.27	10	25	25.2	0.32	210	345
R33	0.33	10	25	25.2	0.35	190	330
R39	0.39	10	25	25.2	0.39	175	305
R47	0.47	10	25	25.2	0.44	160	290
R56	0.56	10	25	25.2	0.49	150	275
R68	0.68	10	25	25.2	0.55	135	260
R82	0.82	10	25	25.2	0.61	125	245
1R0	1.00	5/10	30	7.96	0.69	115	230
1R2	1.20	5/10	30	7.96	0.75	100	215
1R5	1.50	5/10	30	7.96	0.75	90	210
1R8	1.80	5/10	30	7.96	0.82	85	200
2R2	2.20	5/10	30	7.96	0.95	80	190
2R7	2.70	5/10	30	7.96	1.10	75	180
3R3	3.30	5/10	30	7.96	1.20	65	180
3R9	3.90	5/10	30	7.96	1.30	60	175
4R7	4.70	5/10	30	7.96	1.50	55	165
5R6	5.60	5/10	30	7.96	1.60	50	160
6R8	6.80	5/10	30	7.96	1.80	45	150
8R2	8.20	5/10	30	7.96	2.00	40	140
100	10.00	5/10	30	2.52	2.10	36	140
120	12.00	5/10	30	2.52	2.50	33	125
150	15.00	5/10	30	2.52	2.80	30	120
180	18.00	5/10	30	2.52	3.30	27	110
220	22.00	5/10	30	2.52	3.70	25	105
270	27.00	5/10	30	2.52	5.00	22	90
330	33.00	5/10	30	2.52	5.60	20	85
390	39.00	5/10	30	2.52	6.40	20	80
470	47.00	5/10	30	2.52	7.00	15	75
560	56.00	5/10	30	2.52	8.00	15	70
680	68.00	5/10	30	2.52	9.00	15	65
820	82.00	5/10	30	2.52	10.00	11	60
101	100.00	5/10	20	0.796	10.00	10	60
121	120.00	5/10	20	0.796	11.00	10	55
151	150.00	5/10	20	0.796	15.00	8	50
181	180.00	5/10	20	0.796	17.00	7	50
221	220.00	5/10	20	0.796	21.00	7	45

ELECTRICAL - Style S (Shielded)

Inductance Code	Inductance (μ H)	Tolerance (\pm %)	Q Min	LQ Test Freq. (MHz)	Rdc Max (W)	S.R.F. (MHz)	Idc (mA) Max
100	10	10	40	1.0	1.80	30	18
120	12	10	40	1.0	2.00	28	17
150	15	10	40	1.0	2.20	25	15
180	18	10	40	1.0	2.50	23	13
220	22	10	40	1.0	2.80	20	12
270	27	10	40	1.0	3.20	18	10
330	33	10	40	1.0	3.50	17	10
390	39	10	40	1.0	3.80	15	9
470	47	10	40	1.0	4.00	14	8
560	56	10	40	1.0	4.50	13	7
680	68	10	40	1.0	5.00	12	6
820	82	10	40	1.0	6.00	11	6
101	100	10	40	1.0	7.00	10	5
121	120	10	40	1.0	8.00	9	5
151	150	10	40	0.1	9.00	5	5
181	180	10	40	0.1	11.00	5	5
221	220	10	40	0.1	12.00	4	5
271	270	10	40	0.1	14.00	4	5

ELECTRICAL - Style P (High Current)

Inductance Code	Inductance (μ H)	Tolerance (\pm %)	Q Min	LQ Test Freq. (MHz)	Rdc Max (Ω)	S.R.F. (MHz)	Idc (mA) Max
1R0	1.0	20	7	7.96	0.15	150	600
1R5	1.5	20	7	7.96	0.18	110	550
2R2	2.2	20	7	7.96	0.23	80	500
3R3	3.3	20	7	7.96	0.28	58	400
4R7	4.7	20	7	7.96	0.34	46	350
6R8	6.8	20	7	7.96	0.42	38	300
100	10.0	10	15	2.52	0.50	23	240
120	12.0	10	15	2.52	0.60	21	230
150	15.0	10	15	2.52	0.74	18	220
180	18.0	10	15	2.52	0.90	17	205
220	22.0	10	15	2.52	1.15	15	185
270	27.0	10	15	2.52	1.45	13	165
330	33.0	10	15	2.52	1.65	12	155
390	39.0	10	15	2.52	1.90	11	145
470	47.0	10	15	2.52	2.25	9.5	135
560	56.0	10	15	2.52	3.30	8.5	110
680	68.0	10	15	2.52	3.70	7.5	105
820	82.0	10	15	2.52	4.20	7.0	100
101	100.0	10	20	0.796	5.00	6.5	90
121	120.0	10	20	0.796	7.00	6.5	75
151	150.0	10	20	0.796	8.00	5.5	70
181	180.0	10	20	0.796	9.50	5.0	65
221	220.0	10	20	0.796	11.00	4.0	60
271	270.0	10	20	0.796	14.50	3.5	55
331	330.0	10	20	0.796	16.00	3.0	50

ELECTRICAL - Style L (Low Inductance)

Inductance Code	Inductance (μ H)	Tolerance (\pm %)	Q Min	Q Test Freq. (MHz)	Q Test Freq. (MHz)	Rdc Max (Ω)	S.R.F. (MHz)	Idc (mA) Max
47N	0.047	20	10	100	100	0.20	680	450
56N	0.056	20	10	100	100	0.22	600	420
68N	0.068	20	10	100	100	0.25	540	400
82N	0.082	20	10	100	100	0.27	500	380
R10	0.10	20	10	100	100	0.30	450	360
R12	0.12	20	10	25.2	25.2	0.67	400	240
R15	0.15	20	10	25.2	25.2	0.72	350	230
R18	0.18	20	10	25.2	25.2	0.81	320	220
R22	0.22	10	10	1.0	25.2	0.90	280	210
R27	0.27	10	10	1.0	25.2	1.00	250	200
R33	0.33	10	10	1.0	25.2	1.10	220	190
R39	0.39	10	10	1.0	25.2	1.20	200	180
R47	0.47	10	10	1.0	25.2	1.40	180	175
R56	0.56	10	10	1.0	25.2	1.50	160	170
R68	0.68	10	10	1.0	25.2	1.70	150	155
R82	0.82	10	10	1.0	25.2	1.90	135	145
1R0	1.00	5	13	1.0	7.96	2.10	120	125
1R2	1.20	5	13	1.0	7.96	2.30	110	120
1R5	1.50	5	13	1.0	7.96	2.70	95	115
1R8	1.80	5	13	1.0	7.96	3.00	85	110
2R2	2.20	5	13	1.0	7.96	3.20	80	110
2R7	2.70	5	13	1.0	7.96	3.60	70	105
3R3	3.30	5	13	1.0	7.96	4.20	62	100
3R9	3.90	5	13	1.0	7.96	4.40	57	95
4R7	4.70	5	13	1.0	7.96	7.70	52	70
5R6	5.60	5	13	1.0	7.96	8.70	46	65
6R8	6.80	5	13	1.0	7.96	10.00	42	60
8R2	8.20	5	13	1.0	7.96	11.00	38	60

ELECTRICAL - Style T (Standard)

Inductance Code	Inductance (μ H)	Tolerance (\pm %)	Q Min	LQ Test Freq. (MHz)	Rdc Max (Ω)	S.R.F. (MHz)	Idc (mA) Max
010	0.010	10	15	100	0.13	2500	450
012	0.012	10	17	100	0.14	2300	450
015	0.015	10	19	100	0.16	2100	450
018	0.018	10	21	100	0.18	1900	450
022	0.022	10	23	100	0.20	1700	450
027	0.027	10	23	100	0.22	1500	450
033	0.033	5/10	25	100	0.24	1400	450
039	0.039	5/10	25	100	0.27	1300	450
047	0.047	5/10	26	100	0.30	1200	450
056	0.056	5/10	26	100	0.33	1100	450
068	0.068	5/10	27	100	0.36	1000	450
082	0.082	5/10	27	100	0.40	900	450
R10	0.10	5/10	28	100	0.44	700	450
R12	0.12	5/10	30	25.2	0.22	500	450
R15	0.15	5/10	30	25.2	0.25	450	450
R18	0.18	5/10	30	25.2	0.28	400	450
R22	0.22	5/10	30	25.2	0.32	350	450
R27	0.27	5/10	30	25.2	0.36	320	450
R33	0.33	5/10	30	25.2	0.40	300	450
R39	0.39	5/10	30	25.2	0.45	250	450
R47	0.47	5/10	30	25.2	0.50	220	450
R56	0.56	5/10	30	25.2	0.55	180	450
R68	0.68	5/10	30	25.2	0.60	160	450
R82	0.82	5/10	30	25.2	0.65	140	450
1R0	1.0	5	30	7.96	0.70	120	400
1R2	1.2	5	30	7.96	0.75	100	390
1R5	1.5	5	30	7.96	0.85	85	370
1R8	1.8	5	30	7.96	0.90	80	350
2R2	2.2	5	30	7.96	1.00	75	320
2R7	2.7	5	30	7.96	1.10	70	290
3R3	3.3	5	30	7.96	1.20	60	260
3R9	3.9	5	30	7.96	1.30	55	250
4R7	4.7	5	30	7.96	1.50	50	220
5R6	5.6	5	30	7.96	1.60	45	200
6R8	6.8	5	30	7.96	1.80	40	180
8R2	8.2	5	30	7.96	2.00	35	170
100	10.0	5	30	2.52	2.10	30	150
120	12.0	5	30	2.52	2.50	20	140
150	15.0	5	30	2.52	2.80	20	130
180	18.0	5	30	2.52	3.30	20	120
220	22.0	5	30	2.52	3.70	20	110
270	27.0	5	30	2.52	5.00	20	80
330	33.0	5	30	2.52	5.60	17	70
390	39.0	5	30	2.52	6.40	16	65
470	47.0	5	30	2.52	7.00	15	60
560	56.0	5	30	2.52	8.00	13	55
680	68.0	5	30	2.52	9.00	12	50
820	82.0	5	30	2.52	10.00	11	45
101	100.0	5	20	0.796	10.00	10	40
121	120.0	5	20	0.796	11.00	10	70
151	150.0	5	20	0.796	15.00	8	65
181	180.0	5	20	0.796	17.00	7	60
221	220.0	5	20	0.796	21.00	7	50
271	270.0	5	20	0.796	28.00	6	45
331	330.0	5	20	0.796	34.00	5	40
391	390.0	5	20	0.796	42.00	5	35
471	470.0	5	2.0	0.796	40.00	4	25

TEMPERATURE

Temperature Range (Storage): -40°C to +100°C
 Temperature Range (Operating): -20°C to +100°C
 Resistance to Soldering: 260°C for 10 seconds.

DIMENSIONS

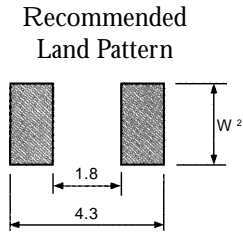

Package	W ¹	W ²
Type T	1.10	1.30
Type M, S, L, P	1.90	2.15

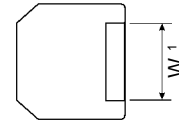
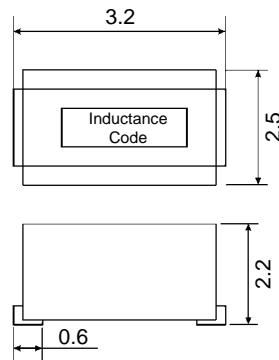

PACKAGING (TAPE)

To meet EIA 48
IEC 286 PT3

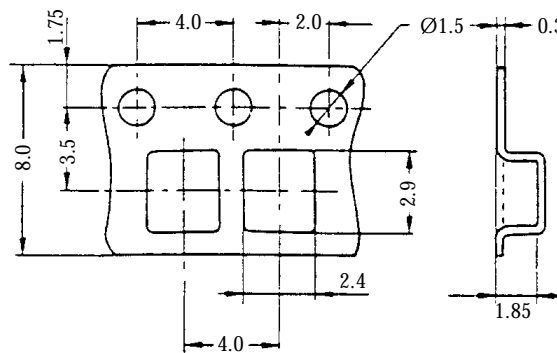

PACKAGING (REEL)

Tape and Reel Specification

- Style M ~ 2000 pieces per 7" Reel
- Style L ~ 2000 pieces per 7" Reel
- Style S ~ 2000 pieces per 7" Reel
- Style T ~ 2000 pieces per 7" Reel
- Style P ~ 2000 pieces per 7" Reel

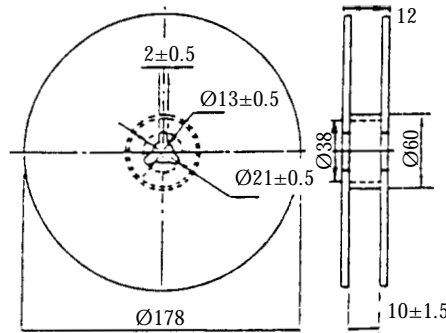

SOLDERING

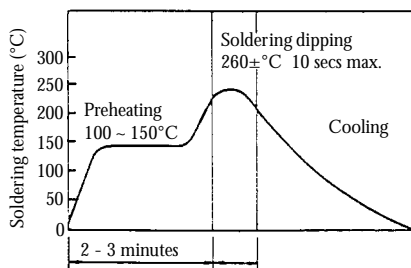

FLOW SOLDERING

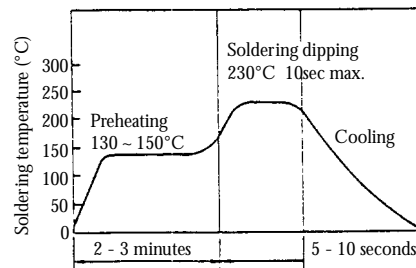

REFLOW SOLDERING

3612

T

1R5

K

HOW TO ORDER

Common Part	Style	Inductance	Tolerance
3612 12:10 Size	T - Standard Series L - Low Inductance P - High Current M - Economy S - Shielded	See Relevant Table for Inductance Code	J - ± 5% K - ± 10% M - ± 20%



Meggit Electronic Components Ltd. Ohmic House, Westmead Industrial Estate, Swindon, Wilts. SN5 7US
 Telephone: (01793) 487301 (Admin.) (01793) 611666 (Sales) Email: sales@megelec.co.uk Fax: (01793) 611777

This publication is issued to provide outline information only and (unless specifically agreed to the contrary by the Company in writing) is not to form part of any order or be regarded as a representation relating to the products or service concerned. We reserve the right to alter without notice the specification, design, price or conditions of supply of any product or service. Whilst Meggit Electronic Components products are of the very highest quality and reliability, all electronic components can occasionally be subject to failure. Where failure of a Meggit Electronic Components product could result in life threatening consequences, then the circuit and application must be discussed with the Company. Such areas might include ECG, respiratory, and other medical and nuclear applications and any non fail safe applications circuit.