

## 2110

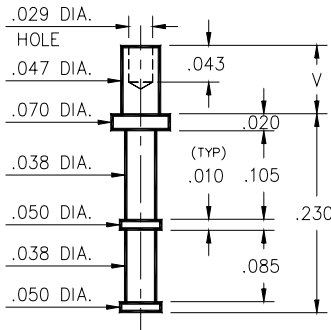

**2110-X-00-XX-00-00-07-0**  
Swage mount in .052 hole

- X -	Board Thickness	Length V
1	.031	.049
2	.062	.082

## 2333

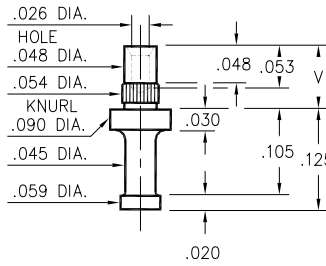

**2333-X-00-XX-00-00-07-0**  
Press-fit and swage in .052 mounting hole

- X -	Board Thickness	Length V
1	.078	.103
2	.062	.087
3	.047	.072

## 2821

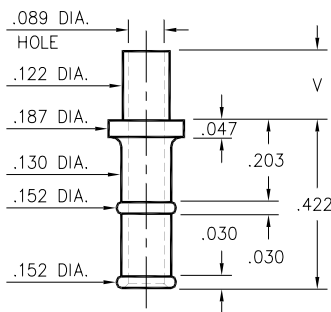

**2821-X-00-XX-00-00-07-0**  
Swage mount in .125 hole

- X -	Board Thickness	Length V
2	.062	.109
3	.094	.141
4	.125	.172

## 2533

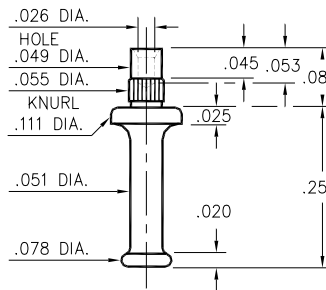

**2533-0-00-XX-00-00-07-0**  
Press-fit & swage in .052 mtg. hole. For .062 thick board

## 2101

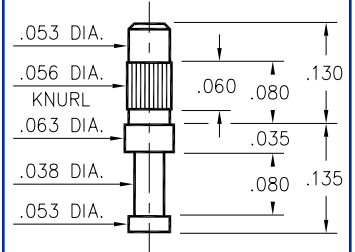

**2101-3-00-XX-00-00-07-0**  
Press-fit in .053 mtg. hole. For .062 to .094 thick board

## 2316/2317/2708

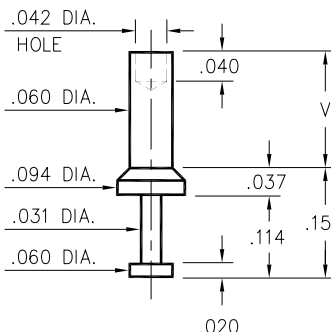

**2316-X-00-XX-00-00-07-0**  
Swage mount in .064 hole

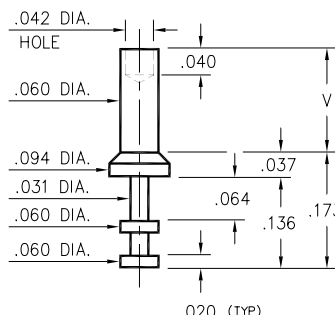

**2317-X-00-XX-00-00-07-0**  
Swage mount in .064 hole

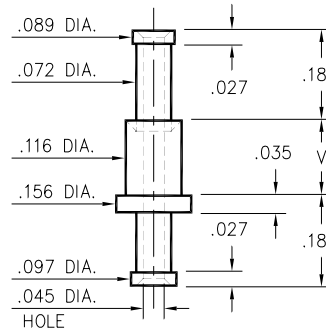

**2708-X-00-XX-00-00-07-0**  
Swage mount in .120 hole

- X -	Board Thickness	Length V
1	.031	.062
2	.062	.094
3	.094	.125
4	.125	.156

### SPECIFICATIONS

**PIN MATERIAL:**  
Brass Alloy 360, 1/2 Hard  
Swage pins are annealed

**DIMENSION IN INCHES**  
**TOLERANCES ON:**  
LENGTHS: ±.005  
DIAMETERS: ±.002  
ANGLES: ± 2°

**ORDER CODE: 2XXX - X - 00 - XX - 00 - 00 - 07 - 0**

**BASIC PART #** →

**SPECIFY PIN FINISH:**  
**01** 200μ" TIN/LEAD OVER NICKEL  
**44** 300μ" SILVER OVER COPPER  
**50** 300μ" ELECTRO-SOLDER (60/40 SnPb)