

Shape and Size : (Dimensions are in mm)

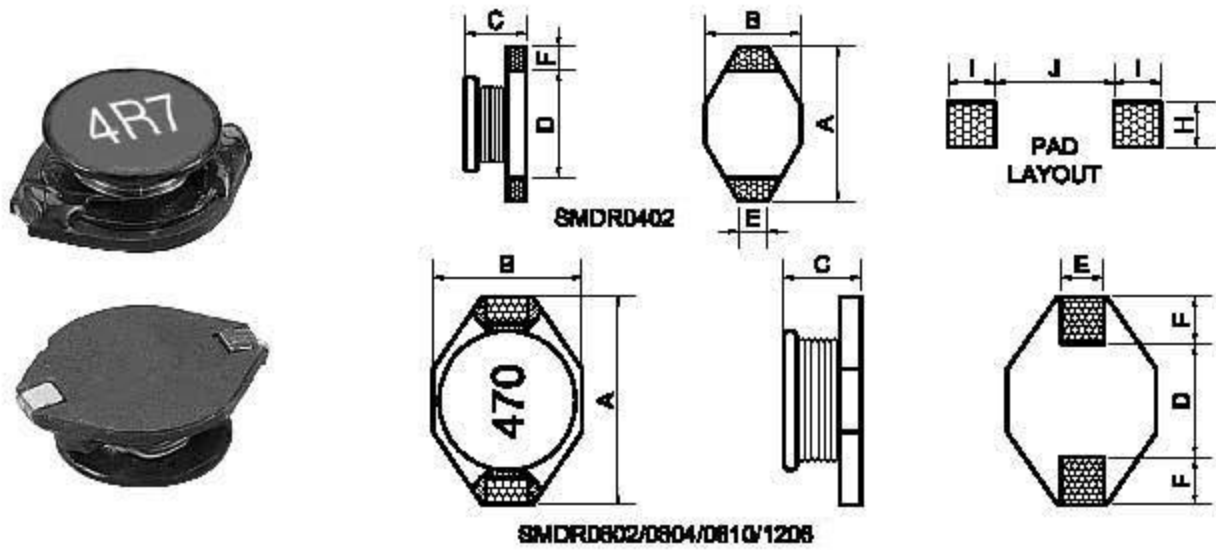

ITEM	A (max)	B (max)	C (max)	D	E	F	H	I	J
SMDR0402	8.80	4.45	2.92	4.32	1.27	1.02	3.58	1.4	4.08
SMDR0802	12.95	9.40	3.50	7.82	2.54	2.54	2.79	2.92	7.37
SMDR0804	12.95	9.40	5.21	7.82	2.54	2.54	2.79	2.92	7.37
SMDR0810	12.95	9.40	11.43	7.82	2.54	2.54	2.79	2.92	7.37
SMDR1206	18.54	15.24	7.11	12.7	2.54	2.54	2.79	2.92	12.45

Features :

- High power, High saturation, Low resistance.
- Ideal inductors for DC-DC conversion in notebook computer, PDAs, Step-up or step-down converters, flash memory programmers, etc.
- SMDR0402 used ceramic base with gold-plating.
- The others used LCP plastic base.

Ordering Information :

- S M DR0804 - 470 M**
- (1) (2) (3) (4)
- (1)Type : **Surface Mount**
- (2)Style : **DR Core OD=8.5mm H=4.0mm .**
- (3)Inductance : **470** for **47** uH.
- (4)Inductance tolerance : **K** : ±10% ; **M** : ±20%.

Inductance and rated current ranges :

- SMDR0402 1.0~1000uH 2.9~0.07A
- SMDR0802 10 ~1000 uH 2.0~0.05A
- SMDR0804 1.0~1000 uH 6.8~0.30A
- SMDR0810 10 ~1000 uH 3.5~0.10A
- SMDR1206 1.0 ~1000 uH 8.6~0.56A

Characteristics :

- I sat: The current when the inductance becomes 10% lower than its initial value. (Ta=20°C)
- I rms: The current when temperature of coil increases up to Max. ΔT=40°C. (Ta=20°C).
- Operating temperature : -40 to 85 °C.

Test equipments :

- L : Agilent 4284A LCR meter @100kHz 0.1V.
- DC Resistance : Milli-ohm meter or equivalent.
- SRF: Agilent 4291B RF Impedance Analyzer .
- Electrical specifications at 25 °C.

Applications :

- Portable telephones .
- Personable computers.
- DC/DC converters, etc.
- Other various electronic appliances.

Part No.	L (μ H)	DCR Max. (OHM)	SRF Ref. (MHz)	I sat (A)	I rms (A)
SMDR0402 -1R0M	1.0	0.05	130	2.9	2.9
SMDR0402 -1R5M	1.5	0.05	115	2.6	2.8
SMDR0402 -2R2M	2.2	0.07	90	2.3	2.4
SMDR0402 -3R3M	3.3	0.08	70	2.0	2.0
SMDR0402 -4R7M	4.7	0.09	50	1.5	1.5
SMDR0402 -6R8M	6.8	0.13	45	1.2	1.4
SMDR0402 -100M	10	0.16	35	1.1	1.1
SMDR0402 -150M	15	0.23	30	0.90	1.2
SMDR0402 -220K	22	0.37	20	0.70	0.80
SMDR0402 -330K	33	0.51	15	0.58	0.60
SMDR0402 -470K	47	0.64	14	0.50	0.50
SMDR0402 -680K	68	0.86	11	0.40	0.40
SMDR0402 -101K	100	1.27	9.0	0.31	0.30
SMDR0402 -151K	150	2.00	6.0	0.27	0.25
SMDR0402 -221K	220	3.11	5.5	0.22	0.20
SMDR0402 -331K	330	3.80	5.0	0.18	0.16
SMDR0402 -471K	470	6.20	4.0	0.16	0.15
SMDR0402 -681K	680	9.20	3.0	0.14	0.12
SMDR0402 -102K	1000	13.8	2.0	0.10	0.07

SMDR0802 -100M	10	0.11	35	2.4	2.0
SMDR0802 -150M	15	0.15	33	2.0	1.5
SMDR0802 -220M	22	0.23	25	1.6	1.3
SMDR0802 -330M	33	0.30	19	1.4	1.1
SMDR0802 -470M	47	0.39	14	1.0	0.80
SMDR0802 -680M	68	0.66	12	0.9	0.70
SMDR0802 -101M	100	0.84	10	0.7	0.60
SMDR0802 -151M	150	1.2	8.0	0.6	0.50
SMDR0802 -221M	220	1.9	6.0	0.5	0.40
SMDR0802 -331M	330	2.7	5.0	0.4	0.30
SMDR0802 -471M	470	4.0	4.0	0.3	0.20
SMDR0802 -681M	680	5.3	3.0	0.2	0.10
SMDR0802 -102M	1000	8.4	2.5	0.1	0.05

SMDR0804 -1R0M	1.0	0.009	100	9.0	6.8
SMDR0804 -1R5M	1.5	0.010	90	8.0	6.4
SMDR0804 -2R2M	2.2	0.012	80	7.0	6.1
SMDR0804 -3R3M	3.3	0.015	65	6.4	5.4
SMDR0804 -4R7M	4.7	0.018	45	5.4	4.8
SMDR0804 -6R8M	6.8	0.027	38	4.6	4.4
SMDR0804 -100M	10	0.038	30	3.8	3.9
SMDR0804 -150M	15	0.046	27	3.0	3.1
SMDR0804 -220M	22	0.085	19	2.6	2.7
SMDR0804 -330M	33	0.100	15	2.0	2.1

Part No.	L (μ H)	DCR Max. (OHM)	SRF Ref. (MHz)	I sat (A)	I rms (A)
SMDR0804 -470M	47	0.14	12	1.6	1.8
SMDR0804 -680M	68	0.20	10	1.4	1.5
SMDR0804 -101M	100	0.28	9.0	1.2	1.3
SMDR0804 -151M	150	0.40	6.0	1.0	1.0
SMDR0804 -221M	220	0.61	5.0	0.80	0.80
SMDR0804 -331M	330	1.02	4.5	0.60	0.60
SMDR0804 -471M	470	1.27	3.5	0.50	0.50
SMDR0804 -681M	680	2.02	2.5	0.40	0.40
SMDR0804 -102M	1000	3.00	2.0	0.30	0.30

SMDR0810 -100M	10	0.04	22	8.0	3.5
SMDR0810 -150M	15	0.05	18	7.0	3.0
SMDR0810 -220M	22	0.066	11	5.5	2.5
SMDR0810 -330M	33	0.08	9.0	4.0	2.0
SMDR0810 -470M	47	0.11	8.0	3.8	1.6
SMDR0810 -680M	68	0.17	7.0	3.0	1.2
SMDR0810 -101M	100	0.22	5.0	2.5	1.2
SMDR0810 -151M	150	0.34	4.0	2.0	0.90
SMDR0810 -221M	220	0.44	3.5	1.6	0.70
SMDR0810 -331M	330	0.70	2.5	1.2	0.60
SMDR0810 -471M	470	0.95	2.0	1.0	0.30
SMDR0810 -681M	680	1.2	2.0	1.0	0.20
SMDR0810 -102M	1000	2.0	1.5	0.80	0.10

SMDR1206 -1R0M	1.0	0.009	80	20	8.6
SMDR1206 -2R2M	2.2	0.014	80	16	7.1
SMDR1206 -3R3M	3.3	0.018	60	14	6.2
SMDR1206 -5R6M	5.6	0.020	40	12	5.3
SMDR1206 -100M	10	0.031	30	10	4.3
SMDR1206 -150M	15	0.036	22	8.0	4.0
SMDR1206 -220M	22	0.047	20	7.0	3.5
SMDR1206 -330M	33	0.066	15	5.5	3.0
SMDR1206 -470M	47	0.086	9.0	4.5	2.6
SMDR1206 -680M	68	0.13	8.0	3.5	2.3
SMDR1206 -101M	100	0.19	7.0	3.0	1.8
SMDR1206 -151M	150	0.25	6.0	2.6	1.5
SMDR1206 -221M	220	0.38	5.0	2.4	1.2
SMDR1206 -331M	330	0.56	4.0	1.9	1.0
SMDR1206 -471M	470	0.85	3.0	1.4	0.82
SMDR1206 -681M	680	1.1	2.5	1.2	0.72
SMDR1206 -102M	1000	1.8	2.0	1.0	0.56