

ADAPTER P/N	SC-ST DUPLEX ADAPTER W/O MOUNTING PLATE		SHIELD ASSEMBLY		
	P/N	COLOR	SLEEVE MATERIAL	P/N	COLOR
86166-1500	86166-1000	BLUE	ZR	86166-0200	BLUE
86167-1500	86167-1000		PHOSPHOR BRONZE		
86166-1510	86166-1010	BEIGE	ZR	86166-0210	BEIGE
86167-1510	86167-1010		PHOSPHOR BRONZE		
86166-1530	86166-1030	BLACK	ZR	86166-0230	BLACK
86167-1530	86167-1030		PHOSPHOR BRONZE		

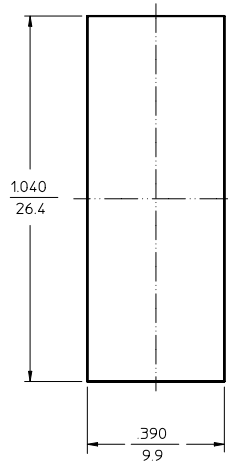

RECOMMENDED
MOUNTING PATTERN

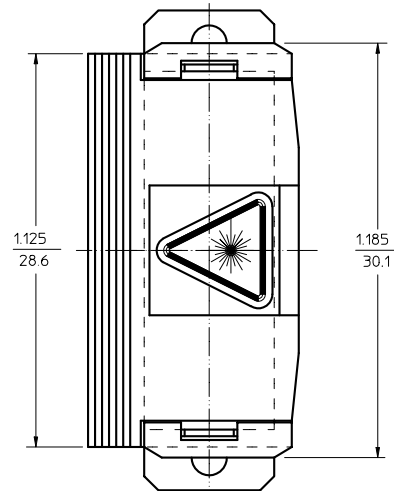
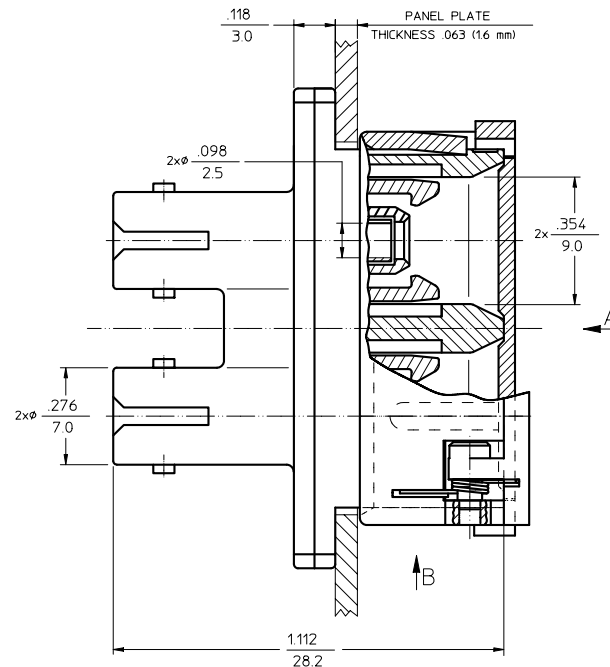
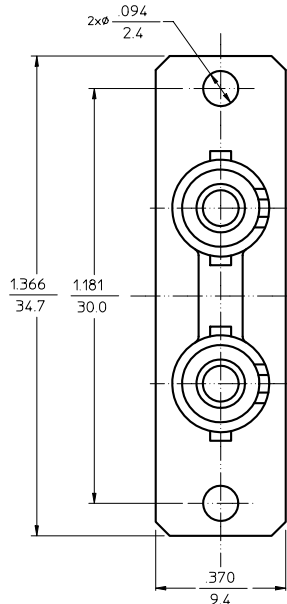

VIEW A
VARIATION 2
FOR LABEL INSTALLATION

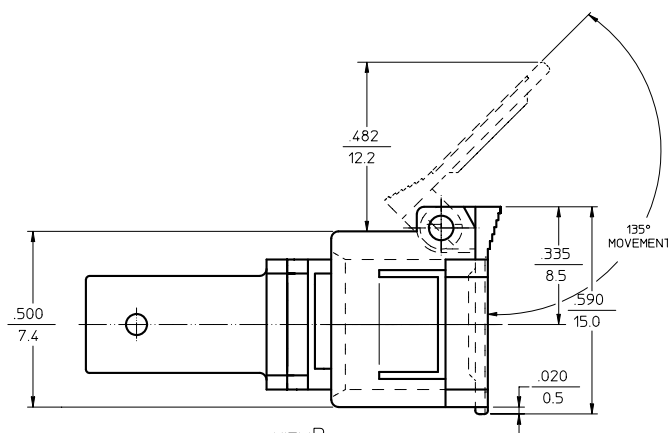

VIEW B

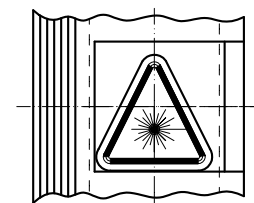

VIEW A
VARIATION 1
FOR LABEL INSTALLATION

- NOTES:
1. ALL DIMENSIONS ARE GIVEN IN $\frac{\text{INCHES}}{\text{mm}}$
 2. LABEL MUST BE INSTALLED AND ORIENTED BY CUSTOMER (SEE VIEW A).

molex Fiber Optics, Inc. Downers Grove, Illinois

RESTRICTED RELEASE DRAWING MAY CHANGE WITHOUT CUSTOMER NOTIFICATION	TITLE: SC-ST DUPLEX ADAPTER WITH SHIELD Drawing No. 8616X-15X0 CD	Size C	Scale 4:1	REV A
			Sheet 1 of 1	