

To : _____

Specification of FUJITSU TFT-LCD module

FLC43XWC8V-06A

Approval

Date :

By :

This Product is designed, developed and manufactured as contemplated for general use, including without limitation, general office use, personal use, household use, and ordinary industrial use, but is not designed, developed and manufactured as contemplated for use accompanying fatal risks or dangers that, unless extremely high safety is secured, could lead directly to death, personal injury, severe physical damage or other loss (hereinafter "High Safety Required Use"), including without limitation, nuclear reaction control in nuclear facility, aircraft flight control, air traffic control, mass transport control, medical life support system, missile launch control in weapon system. If customer's product possibly falls under the category of High Safety Required Use, please consult with our sales representatives in charge before such use. In addition, FDTC shall not be liable against the customer and/or any third party for any claims or damages arising in connection with the High Safety Required Use of the Product without permission.

Specification No. : Tech Bes LCD-00281

Issue Date : July 9, 2004

Issued by :

F. Yamada

Director

Design Dept.

LCD Products Div.

FUJITSU DISPLAY TECHNOLOGIES CORPORATION

TABLE OF CONTENTS

1.APPLICATIONS.....	3
2.PRODUCT NAME AND MODEL NAME	
2-1.Product Name	3
2-2.Model Name	3
3.OVERVIEW	3
4.CONFIGURATION.....	3
5.MECHANICAL SPECIFICATIONS	4
6.ABSOLUTE MAXIMUM RATINGS	5
7.RECOMMENDED OPERATING CONDITIONS.....	5
8.ELECTRICAL SPECIFICATIONS	6
9.OPTICAL SPECIFICATIONS.....	8
10.INTERFACE SPECIFICATIONS	
10-1.Signal descriptions	12
10-2.Color Data Assignment	15
10-3.Input Signal Timing	16
10-4.Correspondence between Data and Display Position	18
10-5.Power Supply Sequence	18
11.BACKLIGHT SPECIFICATIONS	
11-1.Pin Configuration for Backlight.....	19
11-2.CCFL	19
11-3.Life.....	19
11-4.Lamp Assembly Set (for Replacement)	19
12.APPEARANCE SPECIFICATIONS	
12-1.Zone.....	20
12-2.Bright Spot.....	20
12-3.Test Condition.....	20
12-4.Standard	20
13.ENVIRONMENTAL SPECIFICATIONS	23
14.INDICATIONS	24
15.PACKAGING	25
16.WARRANTY	33
17.PRECAUTIONS	33
18.PRECAUTIONS FOR USE.....	37
19.MISCELLANEOUS.....	37

DOCUMENT CONTROL SECTION

DATE

						FLC43XWC8V-06A	
						Tech Bes LCD-00281	
						CUST.	
EDIT	DATE	DESIG.	CHECK	APPR.	DESCRIPTION	FUJITSU DISPLAY TECHNOLOGIES	
DESIG.			CHECK	APPR.		CORPORATION	2 /

A

A

B

B

C

C

D

D

E

F

1. APPLICATIONS

This specification is applied to the 17.0 in. XGA-WIDE supported TFT-LCD module.

2. PRODUCT NAME AND MODEL NAME

2-1. Product Name : LCD Module

2-2. Model Name : FLC43XWC8V-06A

3. OVERVIEW

This LCD module has a TFT active matrix type liquid crystal panel 1280×768 pixels, and diagonal size of 43cm (17.0-inch).

This module supports 1280×768 XGA-WIDE mode (Non-interlace).

This LCD has a XGA-WIDE-capable 1ch-LVDS interface and can display 16.2 million colors.

By timing control signal, images are displayed on the screen at given value under specified timing.

Control signals to this LCD module are ENAB (Data enable signal), DCLK signal and RGB data signal.

Data signal is transmitted with single port. (8 bit for each R, G, B)

Internal control signal of Timing control IC to Data-IC are 1ch-RSDS signal.

The power supply of this LCD module is +5V DC. This module has the characteristics that apply to TCO'03 and EBU100%.

4. CONFIGURATION

This LCD module consists of a color TFT-LCD panel that mounted with TFT driver ICs, a cold-cathode fluorescent tube back-light, a LVDS interface PCB, a structure and a bezel. And these components are integrated in a LCD module.

Cold-cathode fluorescent tube and lamp holder are replaceable.

Fig.4-1 shows a block diagram of this LCD module.

DOCUMENT CONTROL SECTION

DATE

						FLC43XWC8V-06A	
						Tech Bes LCD-00281	
						CUST.	
EDIT	DATE	DESIG.	CHECK	APPR.	DESCRIPTION	FUJITSU DISPLAY TECHNOLOGIES CORPORATION	
DESIG.			CHECK		APPR.	3 /	

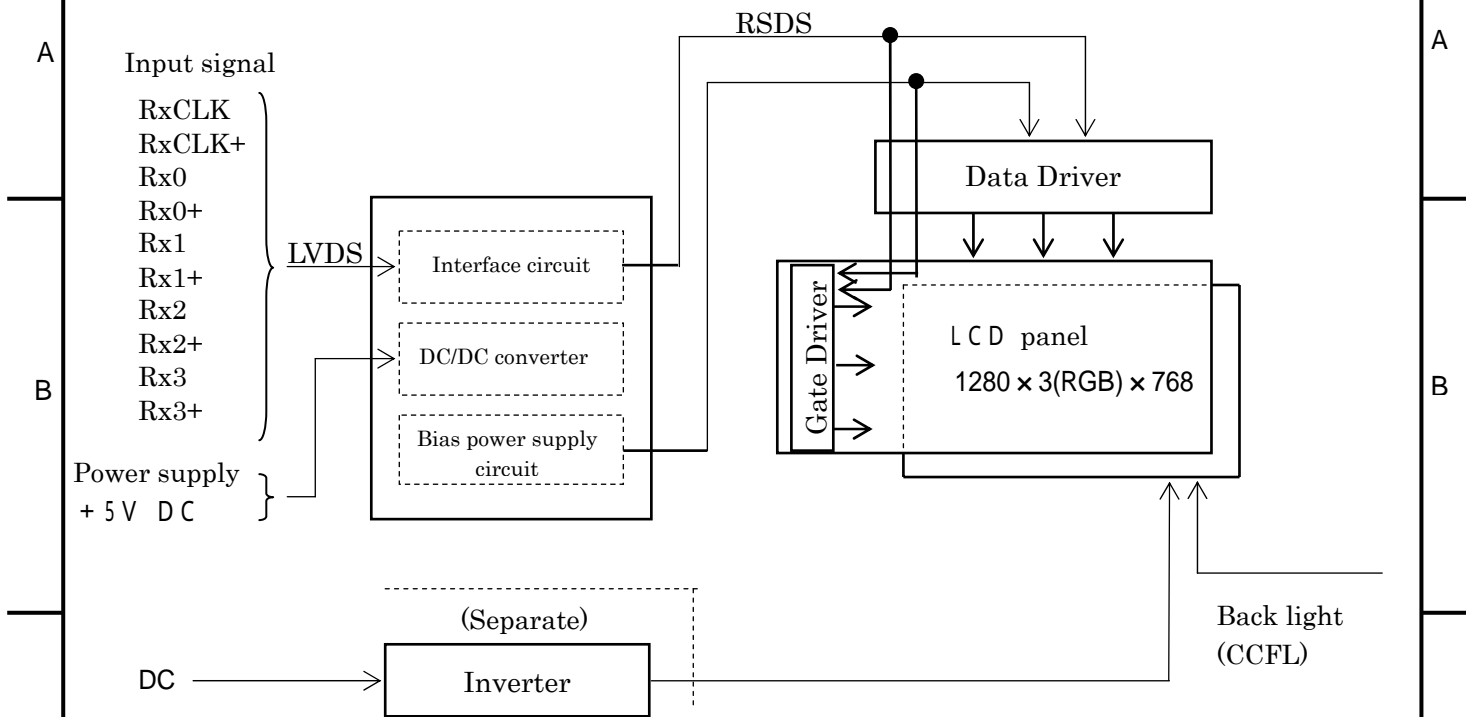

Figure 4-1. Block Diagram

5. MECHANICAL SPECIFICATIONS

Table 5-1 shows the mechanical specifications of this LCD module.

Table 5-1. Mechanical Specifications

Item	Specifications	Unit	Remark
Dimensions	413.8×259.0×15.0(TYP.)	mm	Edge type backlight is used. (φ2.6 CCFL×4) Outward Appearance is shown at last page.
Display Resolution	(1280×3) ×768	—	
Display Dot Area	369.6×221.76	mm	
Dot Pitch	(0.09625×3) ×0.28875	mm	
Aspect Ratio	1 : 1	—	
Weight	2,000 max	g	
FG-SG	Separate	—	

DOCUMENT CONTROL SECTION

DATE

						FLC43XWC8V-06A	
						Tech Bes LCD-00281	
						CUST.	
EDIT	DATE	DESIG.	CHECK	APPR.	DESCRIPTION	FUJITSU DISPLAY TECHNOLOGIES CORPORATION	
DESIG.			CHECK		APPR.	4 /	

8. ELECTRICAL SPECIFICATIONS

Table 8-1 shows the electrical specifications of this LCD module.

Table 8-1. Electrical Specifications

Item	Symbol	Condition	MIN.	TYP.	MAX.	Unit	Remark
Supply Current	I _{CC}	V _{CC} =+5.0±0.25V V _{SS} =0V	—	700	1000	mA	*1
“H” Level Logic Input Voltage	V _{IH}	DCLK=32.498MHz	0.7 × V _{CC}	—	V _{CC} +0.3	V	*2
“L” Level Logic Input Voltage	V _{IL}		GND	—	0.3 × V _{CC}	V	*2
BACK LIGHT CCFL Turn on Voltage	V _S	f _L =50kHz, T _a =25°C	—	1230	1600	V _{rms}	
		f _L =50kHz, T _a =0°C	—	—	1600		
Lighting Voltage	V _L	f _L =50kHz I _L =10.5mA	590	630	670	V _{rms}	*4
Lighting Frequency	f _L	V _L =630V _{rms}	40	50	60	kHz	
*3 Tube Current	I _L	f _L =50kHz V _L =630V _{rms}	9.5	10.5	11.0	mArms	*4

(*1) Typical current value is measured when gray scale (vertical 256 levels) is displayed at V_{CC}=5.0V.

Maximum current value is measured when V stripes with respect to each RGB dot are displayed at V_{CC}=5.0V.

Without rush current.

(*2) Timing control circuit input voltage

(*3) Backlight specifications are valid when using a suitable inverter such as the “FLCV-15” of FDTC.

(*4) Tube current (I_L) shows the value of the current and voltage that is consumed at one lamp. (4 tubes/unit)

This LCD module has 4 lamps. Each 2 lamps are placed at upper and lower side of the display.

2 lamps are connected in parallel. Each low voltage terminals (GND side) are bound into 1 line cable.

(See 11-1. Pin configuration for backlight)

DOCUMENT CONTROL SECTION

DATE

						FLC43XWC8V-06A	
						Tech Bes LCD-00281	
						CUST.	
EDIT	DATE	DESIG.	CHECK	APPR.	DESCRIPTION		FUJITSU DISPLAY TECHNOLOGIES CORPORATION
DESIG.			CHECK		APPR.		6 /

Note 1) Measurement Circuit

Based on Fig.8-1.

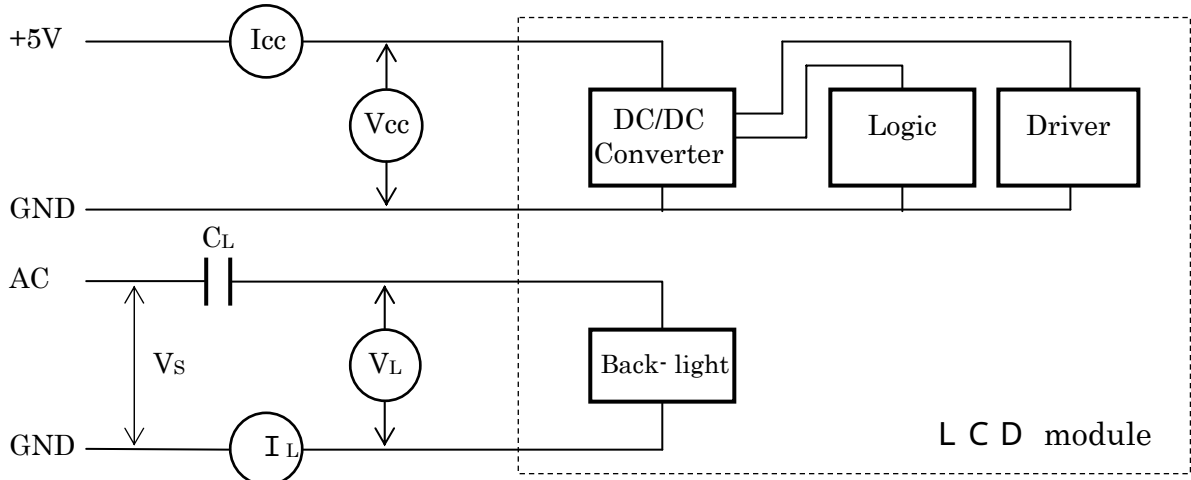

Fig.8-1. Measurement Circuit

Note 2) Equivalent Circuit

Based on Fig.8-2 (a), (b).

Input signals(LVDS-1ch)

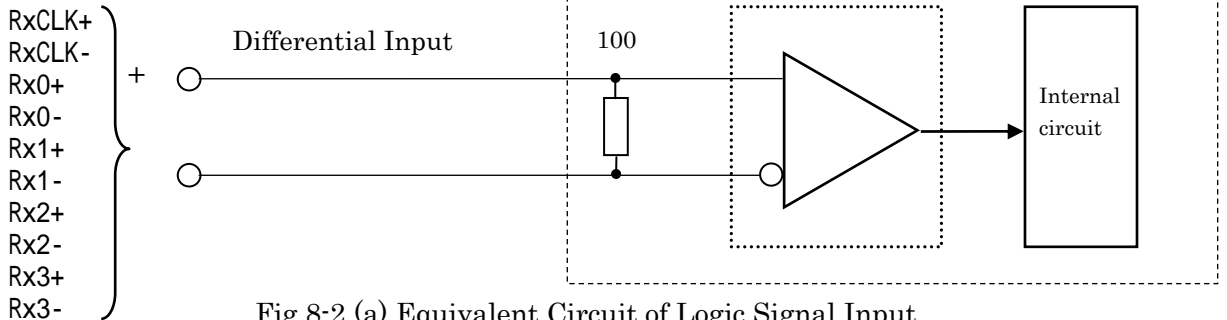
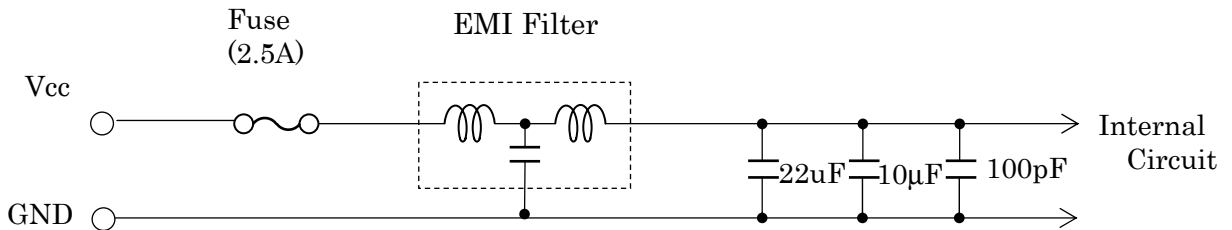

Fig.8-2 (a) Equivalent Circuit of Logic Signal Input



FG
(Frame ground)

Fuse: KAB2402 252 NA29010(Matsuo Electric Co., Ltd.)or equivalent.
EMI Filter: SGM20C1E332-2A(SUMITOMO Metal)or equivalent.

Fig.8-2 (b) Equivalent Circuit of Power Supply

DOCUMENT CONTROL SECTION
DATE

						FLC43XWC8V-06A	
						Tech Bes LCD-00281	
						CUST.	
EDIT	DATE	DESIG.	CHECK	APPR.	DESCRIPTION	FUJITSU DISPLAY TECHNOLOGIES CORPORATION	
DESIG.			CHECK		APPR.	7 /	

9. OPTICAL SPECIFICATIONS

Table 9-1 shows the optical specifications of this LCD module.

Table 9-1. Optical Specifications

Signal timing=Typ, Ta=25°C

Item	Symbol	Condition	Specifications			Unit	Remark			
			MIN.	TYP.	MAX			Note		
Visual Angle	Horizontal	$\theta_{L,R}$	CR \geq 10	$\theta_{U,D}=0^\circ$	85	—	—	deg	(1)(2)	
	Vertical	$\theta_{U,D}$		$\theta_{L,R}=0^\circ$	85	—	—	deg	(3)(5)(6)	
Contrast Ratio		CR	$\theta_{L,R,U,D}=0^\circ$		350	600	—	—	White/Black	(1)(2)(3)(5)
Response Time(ON) (B W)	rise	$\theta_{L,R,U,D}=0^\circ$	Ta=25°C	—	15	30	ms		(1)(4)(5)	
			Ta=0°C	—	50	100	ms			
Response Time(OFF) (W B)	fall	$\theta_{L,R,U,D}=0^\circ$	Ta=25°C	—	10	25	ms			
			Ta=0°C	—	50	100	ms			
Response Time (Rise or Fall) (All gray scale)		AVG	$\theta_{L,R,U,D}=0^\circ$	Ta=25	—	10 12	—	ms	Average of Response Time, *2	
Brightness		I	$\theta_{L,R,U,D}=0^\circ$ VCC=5V, IL=10.5mA (at maximum brightness)	R,G,B signal=All "H"	350	450	—	cd/m ²	White *1	(1)(5)
Brightness Uniformity		ΔI			75	—	—	%		
Chromaticity	W	X			0.283	0.313	0.343	—		(1)(5)
		Y			0.299	0.329	0.359	—		
	R	(x, y)	Red	(0.64, 0.35 Typ.)						
	G		Green	(0.29, 0.59 Typ.)						
	B		Blue	(0.14, 0.08 Typ.)						
-curve					2.4 Typ.					
LCD Panel Type				TFT Color						
Display Mode				Normally Black VA						
Wide Viewing Angle Technology				MVA-Premium						
Optimum Viewing Angle				— (symmetry)					(6)	
Display Color				16.2 million (each 6-bit+2-bit FRC)						
Color of non-display area				Black						
Surface Treatment				Anti-glare (Haze value:25%, 3H(at weight of 300g))						

(*1) Specified value is measured in 20~30 minutes after lighting on (LCD module single).
 A required value may not be achieved on condition that LCD module is built in the cabinet because of its radiation.
 All items without "Brightness Uniformity" are measured at the center of display board.
 (*2) In case of applying optimized over driving method.
 (Note1) *CS-1000 (MINOLTA Co., Ltd.) , Field=2°, L=500mm
 *Be careful that the luminance meter, which you use, may not be able to get correct brightness
 If it's no set correctly.

DOCUMENT CONTROL SECTION

DATE

						FLC43XWC8V-06A		
						Tech Bes LCD-00281		CUST.
02 20040709		Response time changed						
EDIT	DATE	DESIG.	CHECK	APPR.	DESCRIPTION		FUJITSU DISPLAY TECHNOLOGIES CORPORATION	8 /
DESIG.			CHECK		APPR.			

Note 1) Definition of Viewing Angle (1)

Based on Fig.9-2.

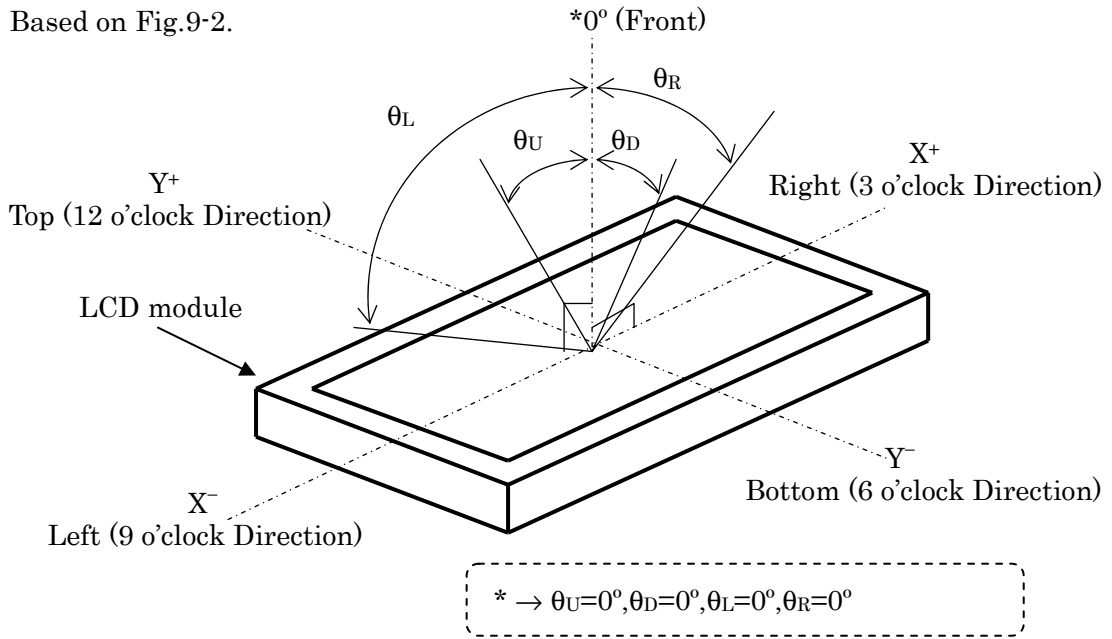

Fig.9-2. Definition of Viewing Angle (1)

Note 2) Definition of Viewing Angle (2)

Based on Fig.9-3.

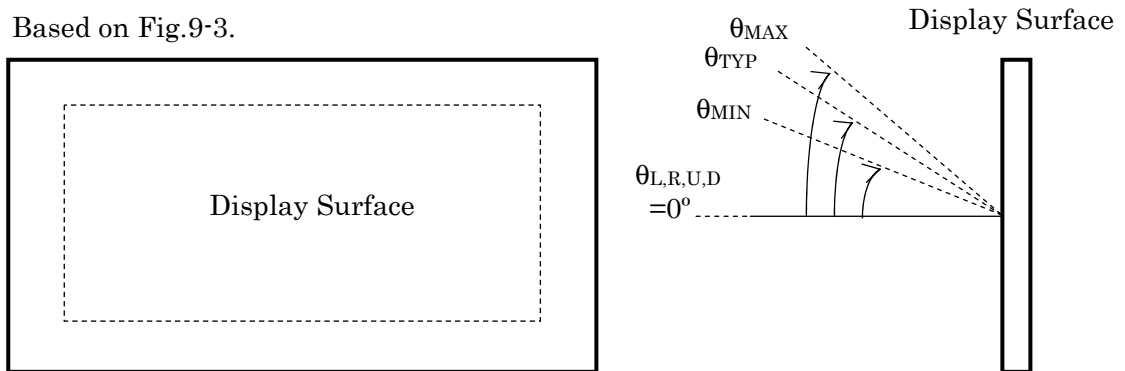

Fig.9-3. Definition of Viewing Angle (2)

Note 3) Definition of Contrast Ratio (CR)

Determined by Formula (1) based on Fig.9-4. Voltage-Brightness Characteristics.

$$= \frac{L_W \text{ (Brightness at white)}}{L_B \text{ (Brightness at black)}} \quad \text{----- (1)}$$

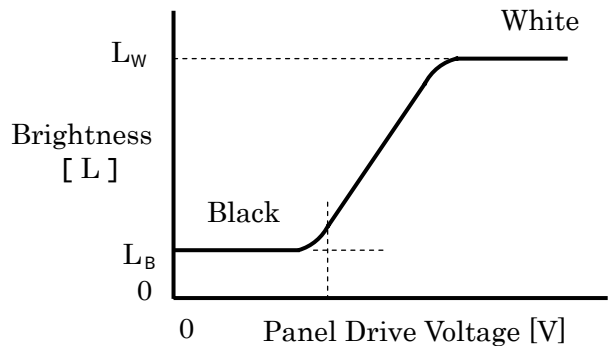

Fig.9-4. Voltage-Brightness Characteristics

DOCUMENT CONTROL SECTION

DATE

						FLC43XWC8V-06A	
						Tech Bes LCD-00281	
						FUJITSU DISPLAY TECHNOLOGIES CORPORATION	
EDIT	DATE	DESIG.	CHECK	APPR.	DESCRIPTION	STAFF	CUST.
DESIG.			CHECK		APPR.	9 /	

Note 4) Definition of Response Time

Based on Figure 9-4.

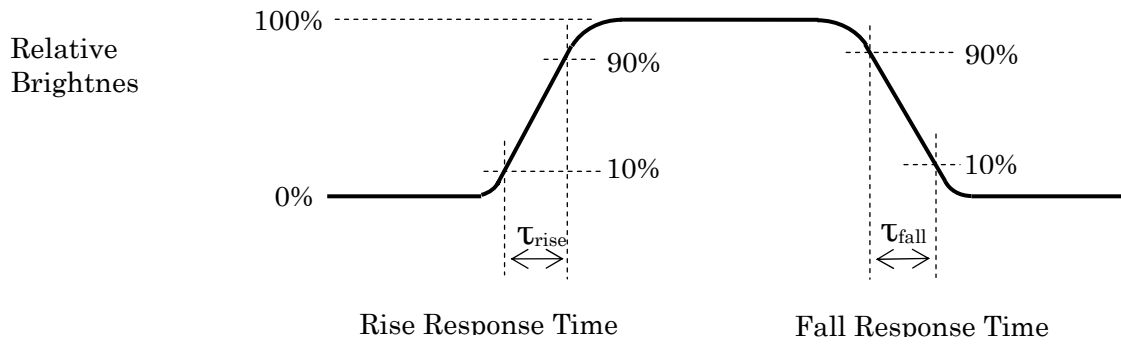

Figure 9-5 Definition of Response Time

Note 5) Contrast Ratio and Response Measurement System

Based on Fig.9-6.

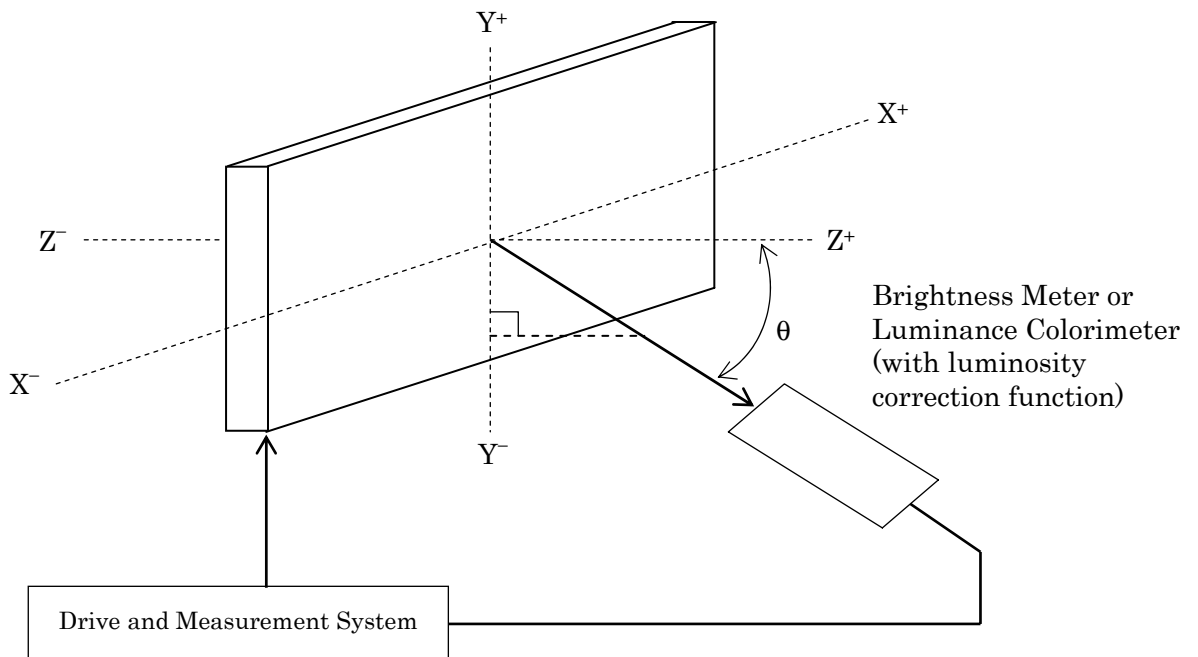

Fig.9-6. Contrast Ratio and Response Time Measurement System

DATE	DOCUMENT CONTROL SECTION

						FLC43XWC8V-06A		
						Tech Bes LCD-00281		CUST.
EDIT	DATE	DESIG.	CHECK	APPR.	DESCRIPTION	FUJITSU DISPLAY TECHNOLOGIES CORPORATION		ST/10/
DESIG.			CHECK	APPR.				10/

Note 6) Definition of Optimum Viewing Angle

Based on Fig.9-7.

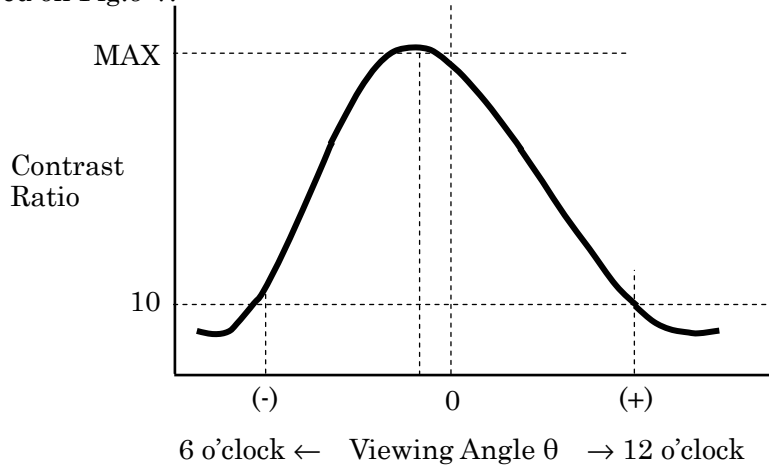

Fig.9-7. Definition of Viewing Angle

Note 7) Definition of Brightness Uniformity

Brightness uniformity is defined by the following formula.

Brightness (I1~I9) are measured at the following 9 points (① ~ ⑨) on the display area shown in Fig.9-8.

$$\text{Brightness Uniformity } (\Delta L) = \frac{|\text{Min. In}|}{|\text{Max. In}|} \times 100 (\%), n=1 \text{ to } 9$$

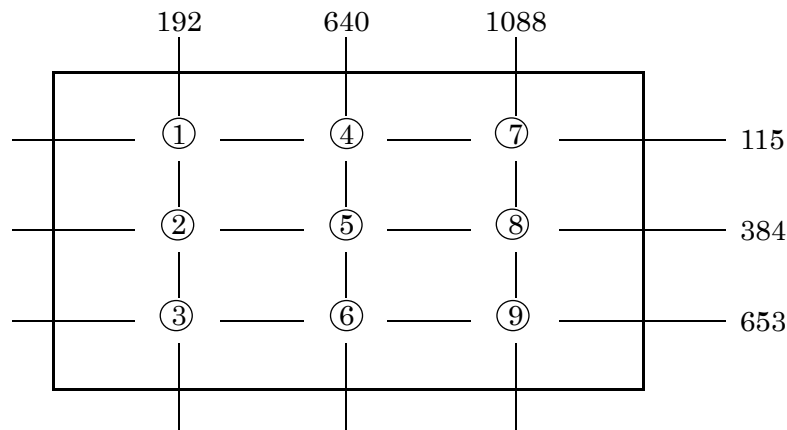

Note) Each measurement point (① ~ ⑨) defines the center spot of Brightness Meter view. The tolerance of measurement position is $\pm 3\text{mm}$.

Fig.9-8. Measurement Points

DOCUMENT CONTROL SECTION	
	DATE

						FLC43XWC8V-06A	
						Tech Bes LCD-00281	
						CUST.	
EDIT	DATE	DESIG.	CHECK	APPR.	DESCRIPTION	FUJITSU DISPLAY TECHNOLOGIES CORPORATION	11 /
DESIG.			CHECK		APPR.		

10. INTERFACE SPECIFICATIONS

10-1-1. Signal descriptions

Table 10-1 shows the description and configuration of Interface signals (CN1).

Table 10-1-1. Interface signals (CN1)

Pin	Symbol	I/O	Function
1	VDD	-	+5V Power suply
2	VDD	-	+5V Power suply
3	GND	-	Ground
4	GND	-	Ground
5	RX0-	↓	LVDS Receiver Signal(-)
6	RX0+	↓	LVDS Receiver Signal(+)
7	GND	-	Ground
8	RX1-	↓	LVDS Receiver Signal(-)
9	RX1+	↓	LVDS Receiver Signal(+)
10	GND	-	Ground
11	RX2-	↓	LVDS Receiver Signal(-)
12	RX2+	↓	LVDS Receiver Signal(+)
13	GND	-	Ground
14	RXCLK-	↓	LVDS Receiver Clock Signal(-)
15	RXCLK+	↓	LVDS Receiver Clock Signal(+)
16	GND	-	Ground
17	RX3-	↓	LVDS Receiver Signal(-)
18	RX3+	↓	LVDS Receiver Signal(+)
19	GND	-	Ground
20	Data Mapping Select Input	I	Low : table 10-1-2 Open or Hi : table 10-1-3

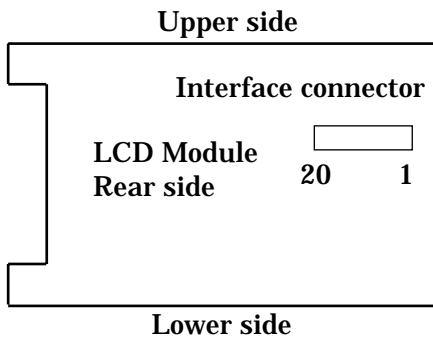

Connector : D14H-20P-1.25H(HIROSE)

User's connector : DF14-20S-1.25 (HIROSE)

Note)When using a interface connector other than the recommended one, a defect in the initial stage or a problem concerning long term reliabilitating may occur.

DATE DOCUMENT CONTROL SECTION

						FLC43XWC8V-06A	
						Tech Bes LCD-00281	
						CUST.	
EDIT	DATE	DESIG.	CHECK	APPR.	DESCRIPTION	FUJITSU DISPLAY TECHNOLOGIES CORPORATION	
DESIG.			CHECK	APPR.			
						12 /	

10-1-2. LVDS Data Mapping 1

Table 10-1-2 shows the LVDS data mapping 1.(DataMappingSelectInput = Low)

Table 10-1-2. LVDS Data Mapping 1

Transmitter (DS90CF385)		Symbol	Interface connector			Receiver (DS90CF386)		LCD Control input
Pin	INPUT		System side	Pin	LCD module	Pin	OUTPUT	
51	TxIN0	R 0	TxOUT0- TxOUT0+	5 6	RX0- RX0+	27	RxOUT0	IR 0
52	TxIN1	R 1				29	RxOUT1	IR 1
54	TxIN2	R 2				30	RxOUT2	IR 2
55	TxIN3	R 3				32	RxOUT3	IR 3
56	TxIN4	R 4				33	RxOUT4	IR 4
2	TxIN5	R 7	TxOUT3- TxOUT3+	17 18	RX3- RX3+	34	RxOUT5	IR 7
3	TxIN6	R 5	TxOUT0- TxOUT0+	5 6	RX0- RX0+	35	RxOUT6	IR 5
4	TxIN7	G 0				37	RxOUT7	IG 0
6	TxIN8	G 1	TxOUT1- TxOUT1+	8 9	RX1- RX1+	38	RxOUT8	IG 1
7	TxIN9	G 2				39	RxOUT9	IG 2
8	TxIN10	G 6	TxOUT3- TxOUT3+	17 18	RX3- RX3+	41	RxOUT10	IG 6
10	TxIN11	G 7				42	RxOUT11	IG 7
11	TxIN12	G 3	TxOUT1- TxOUT1+	8 9	RX1- RX1+	43	RxOUT12	IG 3
12	TxIN13	G 4				45	RxOUT13	IG 4
14	TxIN14	G 5				46	RxOUT14	IG 5
15	TxIN15	B 0				47	RxOUT15	IB 0
16	TxIN16	B 6	TxOUT3- TxOUT3+	17 18	RX3- RX3+	49	RxOUT16	IB 6
18	TxIN17	B 7				50	RxOUT17	IB 7
19	TxIN18	B 1	TxOUT1- TxOUT1+	8 9	RX1- RX1+	51	RxOUT18	IB 1
20	TxIN19	B 2	TxOUT2- TxOUT2+	11 12	RX2- RX2+	53	RxOUT19	IB 2
22	TxIN20	B 3				54	RxOUT20	IB 3
23	TxIN21	B 4				55	RxOUT21	IB 4
24	TxIN22	B 5				1	RxOUT22	IB 5
25	TxIN23	RESERVED	TxOUT3- TxOUT3+	17 18	RX3- RX3+	2	RxOUT23	Not use
27	TxIN24	RESERVED	TxOUT2- TxOUT2+	11 12	RX2- RX2+	3	RxOUT24	Not use
28	TxIN25	RESERVED				5	RxOUT25	Not use
30	TxIN26	ENAB				6	RxOUT26	ENAB
50	TxIN27	R 6	TxOUT3- TxOUT3+	17 18	RX3- RX3+	7	RxOUT27	IR 6
31	TxCLKIN	DCLK	TxCLKOUT- TxCLKOUT+	14 15	RXCLK- RXCLK+	26	RxCLKOUT	DCLK

DOCUMENT CONTROL SECTION

DATE

						FLC43XWC8V-06A		
						Tech Bes LCD-00281		CUST.
EDIT	DATE	DESIG.	CHECK	APPR.	DESCRIPTION	FUJITSU DISPLAY TECHNOLOGIES CORPORATION		13 /
DESIG.			CHECK	APPR.				

10-1-3. LVDS Data Mapping 2

Table 10-1-3 shows the LVDS data mapping 2.(DataMappingSelectInput = Open or Hi)

Table 10-1-3. LVDS Data Mapping 2

Transmitter (DS90CF385)		Symbol	Interface connector		Receiver (DS90CF386)		LCD Control input	
Pin	INPUT		System side	Pin	LCD module	Pin		OUTPUT
51	TxIN0	R 2	TxOUT0- TxOUT0+	5 6	RX0- RX0+	27	RxOUT0	IR 2
52	TxIN1	R 3				29	RxOUT1	IR 3
54	TxIN2	R 4				30	RxOUT2	IR 4
55	TxIN3	R 5				32	RxOUT3	IR 5
56	TxIN4	R 6				33	RxOUT4	IR 6
2	TxIN5	R 1	TxOUT3- TxOUT3+	17 18	RX3- RX3+	34	RxOUT5	IR 1
3	TxIN6	R 7	TxOUT0- TxOUT0+	5 6	RX0- RX0+	35	RxOUT6	IR 7
4	TxIN7	G 2				37	RxOUT7	IG 2
6	TxIN8	G 3	TxOUT1- TxOUT1+	8 9	RX1- RX1+	38	RxOUT8	IG 3
7	TxIN9	G 4				39	RxOUT9	IG 4
8	TxIN10	G 0	TxOUT3- TxOUT3+	17 18	RX3- RX3+	41	RxOUT10	IG 0
10	TxIN11	G 1				42	RxOUT11	IG 1
11	TxIN12	G 5	TxOUT1- TxOUT1+	8 9	RX1- RX1+	43	RxOUT12	IG 5
12	TxIN13	G 6				45	RxOUT13	IG 6
14	TxIN14	G 7				46	RxOUT14	IG 7
15	TxIN15	B 2				47	RxOUT15	IB 2
16	TxIN16	B 0				TxOUT3- TxOUT3+	17 18	RX3- RX3+
18	TxIN17	B 1	50	RxOUT17	IB 1			
19	TxIN18	B 3	TxOUT1- TxOUT1+	8 9	RX1- RX1+	51	RxOUT18	IB 3
20	TxIN19	B 4	TxOUT2- TxOUT2+	11 12	RX2- RX2+	53	RxOUT19	IB 4
22	TxIN20	B 5				54	RxOUT20	IB 5
23	TxIN21	B 6				55	RxOUT21	IB 6
24	TxIN22	B 7				1	RxOUT22	IB 7
25	TxIN23	RESERVED	TxOUT3- TxOUT3+	17 18	RX3- RX3+	2	RxOUT23	Not use
27	TxIN24	RESERVED	TxOUT2- TxOUT2+	11 12	RX2- RX2+	3	RxOUT24	Not use
28	TxIN25	RESERVED				5	RxOUT25	Not use
30	TxIN26	ENAB				6	RxOUT26	E N A B
50	TxIN27	R 0	TxOUT3- TxOUT3+	17 18	RX3- RX3+	7	RxOUT27	IR 0
31	TxCLKIN	DCLK	TxCLKOUT- TxCLKOUT+	14 15	RXCLK- RXCLK+	26	RxCLKOUT	D C L K

DOCUMENT CONTROL SECTION

DATE

						FLC43XWC8V-06A		
						Tech Bes LCD-00281		CUST.
EDIT	DATE	DESIG.	CHECK	APPR.	DESCRIPTION	FUJITSU DISPLAY TECHNOLOGIES CORPORATION		14 /
DESIG.			CHECK		APPR.			

10-2. Color Data Assignment

Table 10-2 shows the color data assignment.

Table 10-2. Color Data Assignment

Color and Brightness		Input data (0 : Low level , 1 : High level)																							
		R7	R6	R5	R4	R3	R2	R1	R0	G7	G6	G5	G4	G3	G2	G1	G0	B7	B6	B5	B4	B3	B2	B1	B0
Basic Color	Black	0	0	0	0	0	0	0	0	0	0	0	0	0	0	0	0	0	0	0	0	0	0	0	0
	Blue	0	0	0	0	0	0	0	0	0	0	0	0	0	0	0	0	1	1	1	1	1	1	1	1
	Green	0	0	0	0	0	0	0	0	0	1	1	1	1	1	1	1	0	0	0	0	0	0	0	0
	Cyan	0	0	0	0	0	0	0	0	0	1	1	1	1	1	1	1	1	1	1	1	1	1	1	1
	Red	1	1	1	1	1	1	1	1	1	0	0	0	0	0	0	0	0	0	0	0	0	0	0	0
	Magenta	1	1	1	1	1	1	1	1	1	0	0	0	0	0	0	0	0	1	1	1	1	1	1	1
	Yellow	1	1	1	1	1	1	1	1	1	1	1	1	1	1	1	1	0	0	0	0	0	0	0	0
	White	1	1	1	1	1	1	1	1	1	1	1	1	1	1	1	1	1	1	1	1	1	1	1	1
Red	Black	0	0	0	0	0	0	0	0	0	0	0	0	0	0	0	0	0	0	0	0	0	0	0	
	↑	1	0	0	0	0	0	0	0	0	0	0	0	0	0	0	0	0	0	0	0	0	0	0	
	Darker	2	0	0	0	0	0	0	1	0	0	0	0	0	0	0	0	0	0	0	0	0	0	0	
	↑	...	:	:	:	:	:	:	:	:	:	:	:	:	:	:	:	:	:	:	:	:	:	:	
	↓	...	:	:	:	:	:	:	:	:	:	:	:	:	:	:	:	:	:	:	:	:	:	:	
	Brighter	253	1	1	1	1	1	1	0	1	0	0	0	0	0	0	0	0	0	0	0	0	0	0	
Green	Black	0	0	0	0	0	0	0	0	0	0	0	0	0	0	0	0	0	0	0	0	0	0	0	
	↑	1	0	0	0	0	0	0	0	0	0	0	0	0	0	0	1	0	0	0	0	0	0	0	
	Darker	2	0	0	0	0	0	0	0	0	0	0	0	0	0	0	0	0	0	0	0	0	0	0	
	↑	...	:	:	:	:	:	:	:	:	:	:	:	:	:	:	:	:	:	:	:	:	:	:	
	↓	...	:	:	:	:	:	:	:	:	:	:	:	:	:	:	:	:	:	:	:	:	:	:	
	Brighter	253	0	0	0	0	0	0	0	0	1	1	1	1	1	1	0	1	0	0	0	0	0	0	
Blue	Black	0	0	0	0	0	0	0	0	0	0	0	0	0	0	0	0	0	0	0	0	0	0	0	
	↑	1	0	0	0	0	0	0	0	0	0	0	0	0	0	0	0	0	0	0	0	0	0	1	
	Darker	2	0	0	0	0	0	0	0	0	0	0	0	0	0	0	0	0	0	0	0	0	0	0	
	↑	...	:	:	:	:	:	:	:	:	:	:	:	:	:	:	:	:	:	:	:	:	:	:	
	↓	...	:	:	:	:	:	:	:	:	:	:	:	:	:	:	:	:	:	:	:	:	:	:	
	Brighter	253	0	0	0	0	0	0	0	0	0	0	0	0	0	0	0	1	1	1	1	1	1	0	1
Blue	↑	254	0	0	0	0	0	0	0	0	0	0	0	0	0	0	0	1	1	1	1	1	1	0	
	↓	255	0	0	0	0	0	0	0	0	0	0	0	0	0	0	0	1	1	1	1	1	1	0	
Blue	↑	255	0	0	0	0	0	0	0	0	0	0	0	0	0	0	0	1	1	1	1	1	1	1	
	↓	255	0	0	0	0	0	0	0	0	0	0	0	0	0	0	0	1	1	1	1	1	1	1	

Note.1) Definition of gray scale : Color (n) ---"n" indicates gray scale level. The gray scale is brighter as the number is larger.

Note.2) Data; 1: High, 0: Low

Note.3) By inputting 8-bit data signal for each red, green and blue, this module can display 256 gray scale independently for each color. Therefore, the module is able to display 16 million colors. Color data are 24 lines.

DOCUMENT CONTROL SECTION

DATE

										FLC43XWC8V-06A													
										Tech Bes LCD-00281										CUST.			
EDIT	DATE	DESIG.	CHECK	APPR.	DESCRIPTION					FUJITSU DISPLAY TECHNOLOGIES CORPORATION					15 /								
DESIG.			CHECK					APPR.															

10-3. Input Signal Timing

Table 10-3 and Fig.10-3 shows the input signal timing.

Table 10-3. Timing Characteristics

(T=0~50°C, Vcc=5±0.25V)

Item		Symbol	Min.	Typ.	Max.	Unit	Remark		
DCLK signal (Clock)	Period	Tc	12.195	15.382	20.000	ns	fc=1/Tc *1		
	Frequency	fc	50.00	65.01	82.00	MHz			
	Duty	Tch/Tc	45	50	55	%			
	High time	TclkH	5.0	—	—	ns			
	Low time	TclkL	5.0	—	—	ns			
	Rise time	Tclkr	—	—	5.0	ns			
	Fall time	Tclkf	—	—	5.0	ns			
DCLK-Data Timing	Setup time	Tset	4	—	—	ns			
	Hold time	Thold	4	—	—	ns			
Data-ENAB timing	Horizontal	Period	Th	1310	1344	1688	DCLK	*2,3	
		Frequency	fh	35.0	48.3	75.0	kHz		
		Display period	Thd	1280	1280	1280	DCLK		
	Vertical	Period	Tv	776	806	806	Th		16.67ms
		Frequency	1/Tv	50	60	75	Hz		WXGA mode
		Display period	Tvd	768	768	768	Th		*2,3
Data-ENAB timing		Tdn	0	0	0	DCLK	*4		

*1) DCLK signal input must be valid while power supply is applied.

*2) Display position is specified by the ENAB signal only.

·Horizontal display position is specified by the rise of ENAB signal. The data which is latched by the falling edge of 1st DCLK right after the rise of ENAB, is displayed on the left edge of the screen.

·Vertical display position is specified by the rise of ENAB after a "Low" level period equivalent to eight times of horizontal period. The 1st data corresponding to one horizontal line after the rise of ENAB is displayed at the top line of screen.

*3) If a period of ENAB "High" is less than 1280 DCLK or less than 768 lines, the rest of the screen displays black.

*4) The display position does not fit to the screen if a period of ENAB "High" and the effective data period do not synchronize with each other.

*5) The specifications of all are not provided individually.

It is necessary that all of those specifications are satisfied at the same time.

*6)The display quality is guaranteed by the Typ timing.

DOCUMENT CONTROL SECTION

DATE

						FLC43XWC8V-06A	
						Tech Bes LCD-00281	
						CUST.	
EDIT	DATE	DESIG.	CHECK	APPR.	DESCRIPTION	FUJITSU DISPLAY TECHNOLOGIES CORPORATION	
DESIG.			CHECK	APPR.		16 /	

【FLC43XWC8V-06A】

A

DCLK

R0-7
G0-7
B0-7

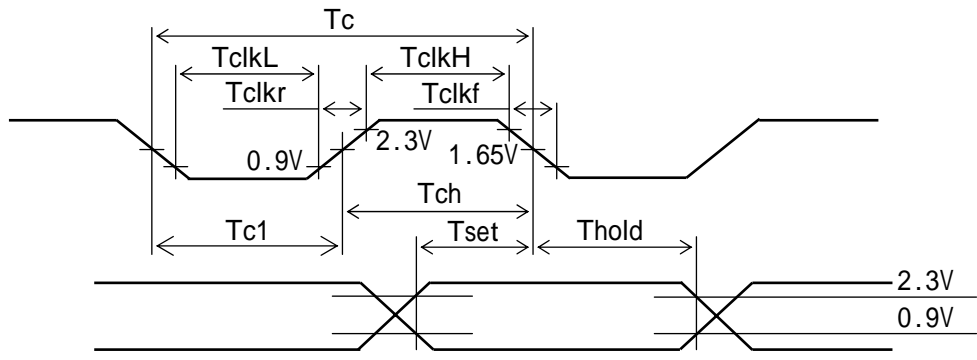

B

R0-7
G0-7
B0-7

ENAB

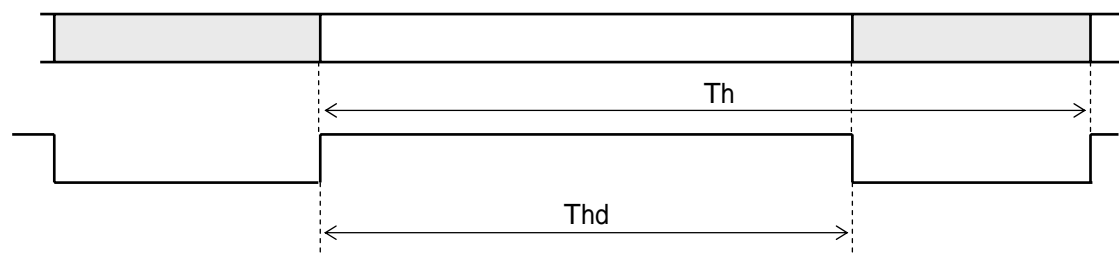

C

R0-7
G0-7
B0-7

ENAB

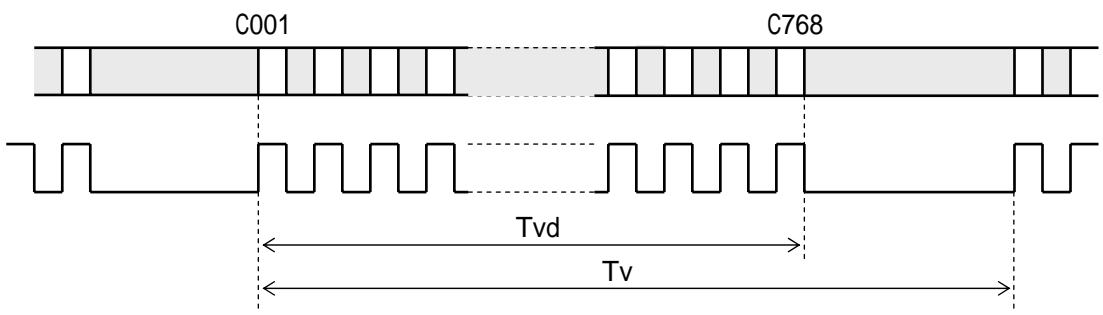

D

DCLK

R0-7
G0-7
B0-7

ENAB

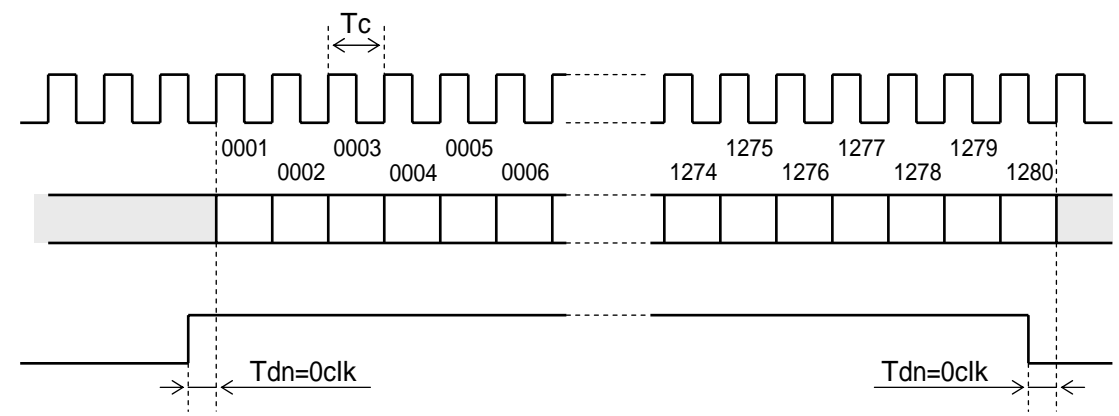

Fig.10-3.Input Signal Timing Chart

DATE DOCUMENT CONTROL SECTION

						FLC43XWC8V-06A		
						Tech Bes LCD-00281		CUST.
EDIT	DATE	DESIG.	CHECK	APPR.	DESCRIPTION	FUJITSU DISPLAY TECHNOLOGIES CORPORATION		17 /
DESIG.			CHECK		APPR.			

10-4. Correspondence between Data and Display Position

Fig.10-4 shows the Correspondence between Data and Display Position.

	S0001	S0002	S0003	S0004	S0005	S0006	S0007	S0008	-----	S3839	S3840
C001	R 0001	G 0001	B 0001	R 0002	G 0002	B 0002	R 0003	G 0003		G 1280	B 1280
C768	R 0001	G 0001	B 0001	R 0002	G 0002	B 0002	R 0003	G 0003		G 1280	B 1280

Fig.10-4. Correspondence Data and Display Position

10-5. Power Supply Sequence

The sequence of input signals and On/Off of the power supply of this LCD module should be in the specification shown in Fig.10-5 to prevent latch-up of the driver ICs and DC driving of the LCD panel.

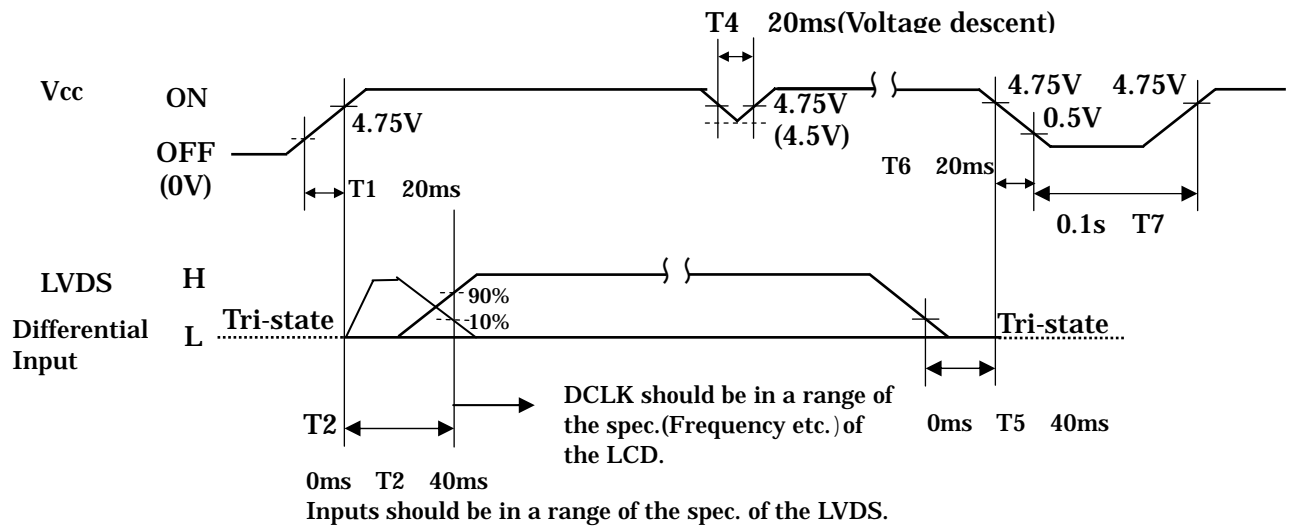

Fig.10-5. Power Supply Sequence

DOCUMENT CONTROL SECTION

DATE

						FLC43XWC8V-06A	
						Tech Bes LCD-00281	
						CUST.	
EDIT	DATE	DESIG.	CHECK	APPR.	DESCRIPTION	FUJITSU DISPLAY TECHNOLOGIES CORPORATION	
DESIG.			CHECK	APPR.		18 /	

11. BACKLIGHT SPECIFICATIONS

11-1. Pin Configuration for Backlight

Table 11-1(a) and 11-1(b) shows the description and pin assignment of the connectors (CN-A and B) for the Backlight of this LCD module.

Table 11-1(a) Pin Assignment of CN-A

Table 11-1(b) Pin Assignment of CN-B

Pin	Signal	Function	Cable color
1	VL1	Power supply for CCFL 1	Red
2	VL2	Power supply for CCFL 2	Red
3	NC		-
4	GND	Ground (for VL1, 2)	White

Pin	Signal	Function	Cable color
1	VL3	Power supply for CCFL 3	Red
2	VL4	Power supply for CCFL 4	Red
3	NC		-
4	GND	Ground (for VL3, 4)	White

Connector : Housing : BHR-04VS-1
 : Contact : SBH-001T-P0.5
 User's Connector : Post with base : SM04(4.0)B-BHS-1-TB
 Supplier : Japan Solderless Terminal Trading Company LTD. (J.S.T.)

11-2. CCFL

Supplier : SANKEN ELECTRIC CO., LTD Part No. SD26E3850E8350B3113000

11-3. Life

The life of the backlight is a minimum of 25,000 hours at the following conditions.

(1) Working conditions

Ambient temperature : 25 ± 5°C
 Tube current(I_L) : (10.5mA or less)

(2) Definition of life

Brightness becomes 50% or below 50% of the minimum brightness value shown in Table 9-1.
 The lamp cannot be lit by the breakdown voltage of 1600Vrms.
 Lamp is flashing.

11-4. Lamp Assembly set (for replacement)

Lamp Assembly set (with charge) is prepared for maintenance.
 This set consists of an upper lamp assembly and a lower lamp assembly.

Type number : FLCL-39

DATE DOCUMENT CONTROL SECTION

						FLC43XWC8V-06A	
						Tech Bes LCD-00281	
						CUST.	
EDIT	DATE	DESIG.	CHECK	APPR.	DESCRIPTION	FUJITSU DISPLAY TECHNOLOGIES CORPORATION	
DESIG.			CHECK		APPR.	19 /	

12. APPEARANCE SPECIFICATIONS

12-1. Zone

- Inside display dot area (369.6× 221.8mm)
- Display dot area means active area.
- One pixel consists of 3 dots (red, green and blue).
- Foreign particle and scratch unharful to display image, such as the foreign particle under polarizer film but outside of the display area and scratch on metal bezel, backlight module or polarizer film out of the display area, etc., are not counted.

12-2. Bright spots

(1) Bright spots by the defect of TFT.

- Visible under bias of 2% ND filterHigh bright spot R•G
- Visible under 5% but invisible under 2% ND filter.....Low bright spot R•G•B
- Invisible under bias of 5% ND filterNot counted

(2) Bright spots by the light passing through tears, breaks, etc in color filter.

- Exceed size of a half dot.....High bright spot
- A half dot or less.....Not counted

(3) Bright spots by the light passing through tears, breaks, etc in chromium mask.

- Exceed 50μmHigh bright spot
- 50μm or lessNot counted

12-3. Test condition

- Inspector must observe the LCD screen from the normal direction under the illumination by a single 20W fluorescent lamp. The distance between the LCD screen and the inspector should be a height of 50cm above the worktable.
The vertical illuminance is 300 to 600lux (reference value).
- Bright spot should be counted under entire black screen.
- Dark spot should be counted under entire white screen.
- Frame frequency should be 60Hz.

12-4. Specifications

Table 12-4 shows the appearance standard.

(Note1) Please do not mistake a single bright spot for a bright spot connection due to Cs(supplemental capacitance) line at the center of each dot.

(Note2) If a pixel is dark partially, it connects into the number of dark spots in accordance with following rule.

(a) $S < 1/3$: Not count. Only one of 4 dark connection is allowed.

(b) $1/3 \leq S < 2/3$: Considered as 0.5 dot.

(c) $2/3 \leq S$: Considered as 1 dot.

(S=Dark spot size/dot size)

(Note3) Min. distance between foreign particles : 100mm

DOCUMENT CONTROL SECTION

DATE

						FLC43XWC8V-06A	
						Tech Bes LCD-00281	
						CUST.	
EDIT	DATE	DESIG.	CHECK	APPR.	DESCRIPTION	FUJITSU DISPLAY TECHNOLOGIES CORPORATION	
DESIG.			CHECK		APPR.	20/	

【FLC43XWC8V-06A】

No.	Item	Judgment method and standard		
1	Bright spot (high and Low)	≤3 dots (Note 1)		
2	Bright spot connection (high and low)	≤1 pair (2 dot connection in horizontal) (Note 1)		
3	Total of bright spot	≤3 dots		
4	Dark spot	≤5 dots (Note 2)		
5	Dark spot connection	≤2 pairs (2 dot connection in horizontal) (Note 2)		
6	Total of dark spot	≤ 5dots (Note 2)		
7	Total of dot defect(bright and dark)	≤ 8 dots		
8	Distance of bright spot	high-high high	≥15mm	
		others	≥ 5mm	
9	Distance of dark spot	≥ 5mm		
10	Scratch on polarizer	W 0.03	Not count	
		0.03 < W 0.05	L 6	Not count
			6 < L 12	5
			12 < L	0
		0.05 < W 0.10	L 0.6	Not count
			0.6 < L 5	3
			5 < L, W × L < 0.5	1
5 < L, 0.5 W × L	0			
0.10 < W	0			
11	Dent on polarizer	D 0.3	Not count	
		0.3 < D 0.4	6	
		0.4 < D	0	
12	Bubble in polarizer	D 0.5	Not count	
		0.5 < D	0	
13	Spot (black/white) by foreign particle	D < 0.5	5	
		0.5 < D	0	
14	Bright spot by fiber foreign particle (under the polarizer. i.e. between the polarizer and the glass) (Note 3)	D 0.2	Not count	
		0.2 < D 0.3	2	
		0.3 < D 0.35	1	
		0.35 < D	0	
15	Line (black /white), scratch by fiber foreign particle	W 0.03	Not count	
		0.03 < W 0.05	L 6	Not count
			6 < L 12	5
			12 < L	0
		0.05 < W 0.1	L 0.6	Not count
			0.6 < L 5	3
5 < L	0			
0.1 < W	(W+L)/2 = D	Count as spot (black/white) of No.13		
16	Mura	Invisible under 6%ND filter from center of display. (Display pattern : Black, White, 50%gray)		

D:Average diameter [mm], W:Width [mm], L:Length [mm], S=(bright spot size)/(dot size)

DOCUMENT CONTROL SECTION

DATE

						FLC43XWC8V-06A	
						Tech Bes LCD-00281	
						CUST.	
EDIT	DATE	DESIG.	CHECK	APPR.	DESCRIPTION	FUJITSU DISPLAY TECHNOLOGIES CORPORATION	
DESIG.			CHECK		APPR.	21/	

Applied area	Item	Condition	Specification										
Display dot area	Display location	Non-lighting	<p>As for the display position in the display dot area, the variation of tolerance between window frame of the upper bezel and dot display area (right, left, up and down) is shown in the following table.</p> <table border="1"> <thead> <tr> <th>Tolerance (X direction)</th> <th>Tolerance (Y direction)</th> </tr> </thead> <tbody> <tr> <td> E-F 1.0mm</td> <td> A-B 1.0mm</td> </tr> <tr> <td> E-H 0.7mm</td> <td> A-D 0.7mm</td> </tr> <tr> <td> F-G 0.7mm</td> <td> B-C 0.7mm</td> </tr> <tr> <td> G-H 1.0mm</td> <td> C-D 1.0mm</td> </tr> </tbody> </table> <p>*The dimension of effective display area, dot display area and display frame should follow the dimensions described in each specification.</p>	Tolerance (X direction)	Tolerance (Y direction)	E-F 1.0mm	A-B 1.0mm	E-H 0.7mm	A-D 0.7mm	F-G 0.7mm	B-C 0.7mm	G-H 1.0mm	C-D 1.0mm
Tolerance (X direction)	Tolerance (Y direction)												
E-F 1.0mm	A-B 1.0mm												
E-H 0.7mm	A-D 0.7mm												
F-G 0.7mm	B-C 0.7mm												
G-H 1.0mm	C-D 1.0mm												

DOCUMENT CONTROL SECTION

DATE

						FLC43XWC8V-06A	
						Tech Bes LCD-00281	
						CUST.	
EDIT	DATE	DESIG.	CHECK	APPR.	DESCRIPTION	FUJITSU DISPLAY TECHNOLOGIES CORPORATION	
DESIG.			CHECK		APPR.	22 /	

13. ENVIRONMENTAL SPECIFICATIONS

Table 13-1 shows the environmental specifications.

Table 13-1. Environmental Specifications

Item	Condition		Remark
Temperature	Operation	0~57°C (Note1)	Temperature on surface of LCD panel (display area.)
	Storage	-20~60°C	
Humidity	Operation	20~85%RH	Maximum wet-bulb temperature should not exceed 29°C. No condensation.
	Storage	5~85%RH	
Vibration	Non-operation	10~500Hz, 1 cycle/20minute, 2G, 1.5mm max, 2hour each X, Y and Z directions	For single module without package.(Note2)
Shock	Non-operation	30G, 6ms, 1time each ± X, ± Y and ± Z directions.	

Note1: Temperature on surface of LCD panel should be under 57 .

Note2: Table 13-2 and Fig. 13-1 show the shock resistance standard when module is packaged.

Table 13-2. Shock Resistance Standard when Module is Packaged

Dropping location	Dropping height	Count
A ~ J	60cm	1 time

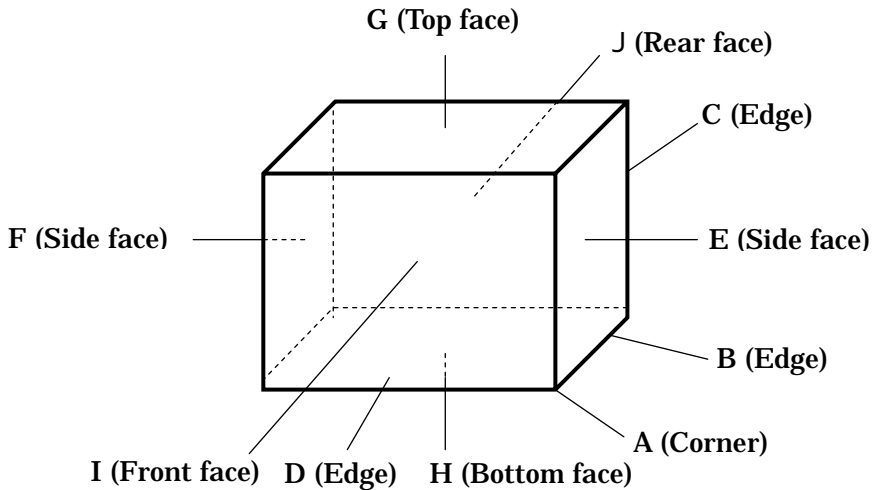

Fig.13-1. Direction to apply shock to package

DOCUMENT CONTROL SECTION

DATE

						FLC43XWC8V-06A	
						Tech Bes LCD-00281	
						CUST.	
EDIT	DATE	DESIG.	CHECK	APPR.	DESCRIPTION	FUJITSU DISPLAY TECHNOLOGIES CORPORATION	
DESIG.			CHECK		APPR.	23/	

14. INDICATIONS

This module has the following indications.

- (1) Product name : LCD unit
- (2) Model number : FLC43XWC8V-06A
- (3) Product drawing number: NA19027-C052

(4) Manufacturing number : 3 X 0 0 0 0 1

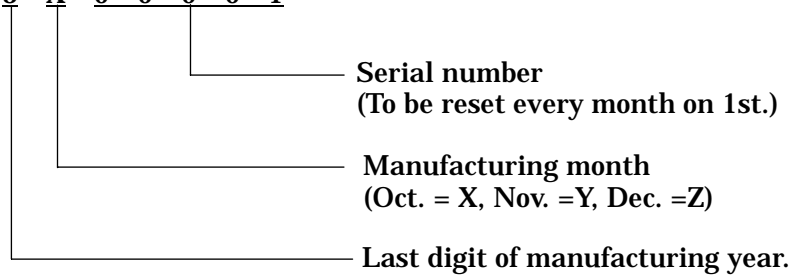

- (5) Version number : 01A (Example)
-1st 2 digits "01" means operational version.
-3rd alphabet means functional version.

(6) Country of origin : MADE IN TAIWAN

(7) Company name : FUJITSU DISPLAY TECHNOLOGIES CORP.

(8) Caution when changing cold-cathode tubes and disposal method of them. (See Fig. 14-1)

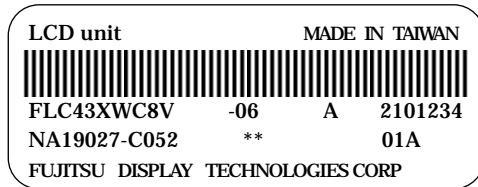
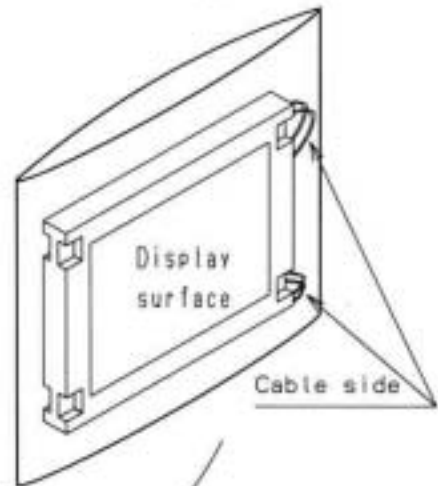
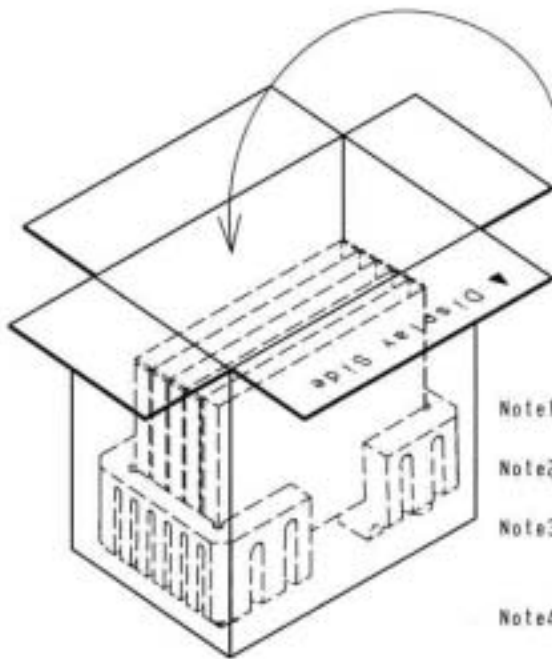

Fig.14-2 Product label (example)

DATE DOCUMENT CONTROL SECTION

						FLC43XWC8V-06A		
						Tech Bes LCD-00281		CUST.
EDIT	DATE	DESIG.	CHECK	APPR.	DESCRIPTION		FUJITSU DISPLAY TECHNOLOGIES CORPORATION	24/
DESIG.			CHECK		APPR.			

Place the unit-packed product in the corrugated carton one by one.



- Note1) When modules are shown from the display side, the cable is located on the right.
- Note2) Insert them with care so that the cable will not be stuck in the partition box.
- Note3) The display side of LCD module and the side of the partition box where the model number is marked should face the same direction.
- Note4) Please confirm that the display side of LCD module and the indication of the display side on the corrugated carton face the same direction.

Fold the anti-electric bag in the same direction.

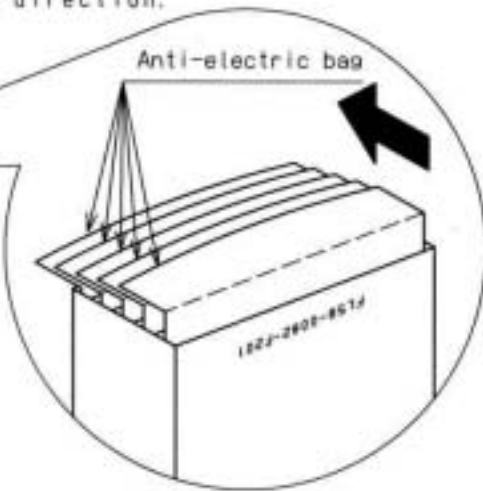
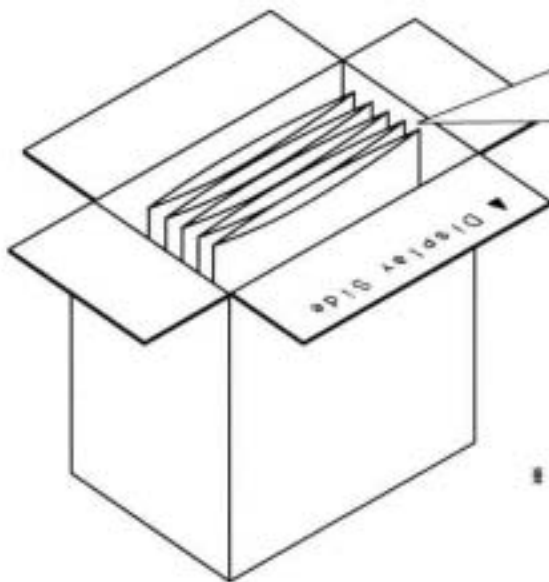

※ Fold each anti-electric bag together to a certain direction as the arrow.

Fig.15-2(d) Packaging Method

DOCUMENT CONTROL SECTION

DATE

EDIT	DATE	DESIG.	CHECK	APPR.	DESCRIPTION
DESIG.			CHECK		APPR.

FLC43XWC8V-06A	
Tech Bes LCD-00281	CUST.
FUJITSU DISPLAY TECHNOLOGIES CORPORATION	29/

Shipping Label

State the following items on shipping label.
Stick the label according to the locating mark on a side face of corrugated carton.

(1) Item to state

- Model No. section : indicate the product model number
- Drawing No. section : indicate the product drawing number
- Quantity section : indicate the quantity of packing
- Revision No. section : indicate the product revision number
- Serial No. of the same packing unit

(2) Position of sticking shipping label

Standard of sticking label

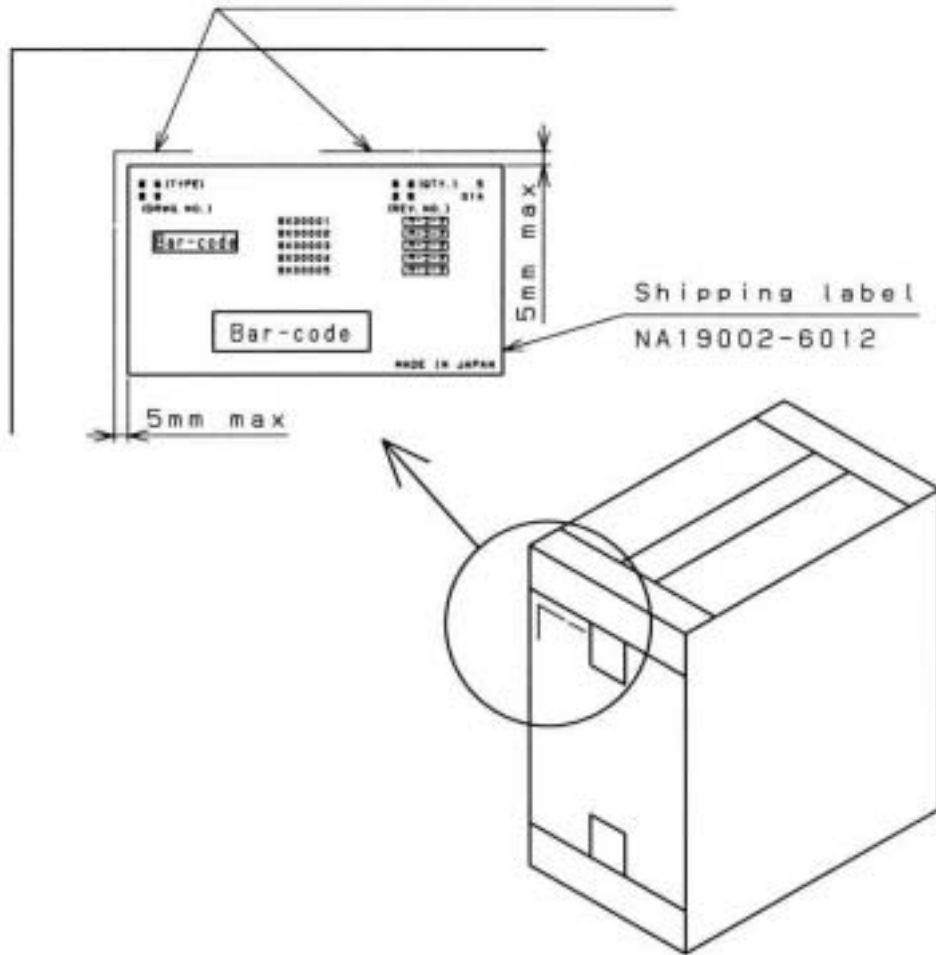

Fig.15-2(i) Packaging Method

DATE DOCUMENT CONTROL SECTION

						FLC43XWC8V-06A	
						Tech Bes LCD-00281	
						CUST.	
EDIT	DATE	DESIG.	CHECK	APPR.	DESCRIPTION	FUJITSU DISPLAY TECHNOLOGIES CORPORATION	
DESIG.			CHECK	APPR.		31/	

16.WARRANTY

The warranty period is one year after manufacturing. Products which fail during this period are repaired or replaced without charge, unless the failure is caused by user.

17.PRECAUTIONS

Adhere to the following precautions to properly use this LCD module.

(1) Fail safe design

LCD module has an inherent chance of failure. Customers must protect against injury, damage or loss from such failures by incorporating safety design measures into your facility and equipment such as redundancy, fire protection, and prevention of over-current levels and other abnormal operating conditions.

(2) Handling of LCD panel

Do not apply any strong mechanical shock to the LCD panel.

Since the LCD panel is made of glass, excessive shock may damage the panel or cause a malfunction.

Do not press hard on the LCD panel surface. (Max 2.0kg/cm²)

In the LCD panel, the gap between two glass plates is kept precisely and uniformly to maintain display's characteristics and reliability.

If the pressure is over 2.0kg/cm², the problem don't return to normal condition.

- (a) Ununiformity of color
- (b) Orientation of liquid crystal becomes disordered

Problem (a) returns to normal after a while. Problem (b) returns to normal if power is shut off once then turned on again.

However these operations should be avoided to insure reliability.

Do not scratch the polarizer film on the LCD panel surface.

- Do not press or rub the display surface with a hard tool, pincet, etc.
- For handling, use cotton or conductive gloves so that the display surface is not stained.
- For If the display surface is stained by dust or dirt, clean it as follows with a soft cloth (deer skin, etc.)

[Dust] Wipe off with a soft cloth. (do not rub.)

[Dirt] Wipe off lightly with a soft cloth after soaking in the clear water and squeezing hard out of water drops. Only if the dirt is hardly wiped off, use isopropyl alcohol or ethanol.

Be careful not to splash the water or the solvent and water penetrated between the polarizer and the LCD panel.

Do not use solvents such as ketone (acetone, etc.) and aromatics (xylene, toluene, etc.)

- If saliva or water drops are left for long time, it may deform partial deformation or discolored. Wipe off immediately in the same way as for dirt.
- Do not allow oil to adhere to the module, since the cleaning of oil is difficult.

Do not place or contact objects on the display surface for a long period of time.

That's because this may make some parts of the LCD module distorted and the display quality may decline.

DOCUMENT CONTROL SECTION

DATE

						FLC43XWC8V-06A	
						Tech Bes LCD-00281	
						CUST.	
EDIT	DATE	DESIG.	CHECK	APPR.	DESCRIPTION		FUJITSU DISPLAY TECHNOLOGIES CORPORATION
DESIG.			CHECK		APPR.		33/

(3) Handling of LCD module

Do not pull the cold-cathode tube cable strongly.

If the cable is pulled with the load of 2kg or more, the cable may be damaged or reliability may decrease.

Assemble the module into user's system in a dust free environment.

If conductive foreign matter adheres to the module, failures may occur.

Take anti-static measures for assembling the module.

Since the LCD module contains CMOS-ICs, the following considerations are necessary.

- For assembling the module, operator should be grounded and wear cotton or conductive gloves.
- Floor of work area and work table to assemble the LCD module should be covered with electrostatic shielding in order to discharge static electricity via an earth wire.
- If necessary, ground operation tools (soldering iron, radio pliers, pincet, etc.).
- Do not take the module out of the conductive bag until the time when the module is assembled.
- Assemble the module under low humidity (50%RH or less).

Do not pull the connecting cable on the rear face of the LCD module strongly.

Do not disassemble or remodel the LCD module.

If this LCD module is disassembled or remodeled, it may have some trouble, or the display quality and reliability may not be assured.

(4) Precautions for operating the LCD module

Adhere to the specified power supply sequence.

If not followed, the CMOS-IC may cause a latch-up, or the DC voltage may be applied the liquid crystal, and a failure or serious deterioration in display quality may occur.

Do not operate the LCD module when condensation is present.

If the LCD module is operated when condensation is on the terminals of the LCD panel, the terminals cause electrochemical reaction, and may reach disconnection. Condensation easily occurs especially when the module is moved from a cold environment to a warm environment.

Trouble that occurs when the LCD module is used at not recommended temperature.

- Operation at high temperature(>60°C) :Display colors shift to blue.
- Storage at high temperature (>60°C) :The polarizer film deteriorates and contrast decreases.
- Operation at low temperature(<0°C) :The response speed decreases considerably.
- Storage at low temperature (<-20°C) :The liquid crystal may solidify and become damaged.

Always input the control signals at the correct timing.

If control signals (DCLK, or ENAB) are not input, or if the timing is out of the specified timing, DC voltage may be applied to the liquid crystal and, as a result, cause image sticking or deterioration of contrast.

DOCUMENT CONTROL SECTION

DATE

						FLC43XWC8V-06A	
						Tech Bes LCD-00281	
						CUST.	
EDIT	DATE	DESIG.	CHECK	APPR.	DESCRIPTION		FUJITSU DISPLAY TECHNOLOGIES CORPORATION
DESIG.			CHECK		APPR.		34/

(5) Precautions on designing module mounting

Do not press the display surface and bottom face of the LCD module.

Display quality or reliability may be deteriorated if the installation of the LCD module is inappropriate and, as a result, excessive pressure is applied to the surface of LCD screen. Brightness uniformity or the reliability of CCFL may decrease if the pressure is applied to the backlight module.

Consider the module mounting design, so that twisting and bending do not occur to the LCD module.

Excessive twisting and bending may damage display quality and reliability.

The power cable length between the LCD module and inverter should not be extended.

Otherwise the backlight may not light or flickering may occur.

Do not make the power cable of the backlight clung to a metal plate, etc.

Backlight frequency current for backlight driving may leak to the metal and desired brightness may not be assured.

When Mounting LCD module with M4 screw(x4) should be screw up under 5.75kgf-cm torque.

(6) Storage method

Do not store the LCD module in an atmosphere of organic solvent or corrosive gas.

In an organic solvent atmosphere, the polarizer film discolors and display quality deteriorates.

In a corrosive gas environment, various problems may occur.

Store the LCD module in a Fujitsu package.

At storing, Fujitsu packages can be stacked up to 4 boxes.

The LCD module is in an anti-static bag. Keep the module in that status.

It is recommended that the storage environment should be humidity controlled, cool and dark.

Recommended storage environment

- Place :Dark (avoid direct sunlight)
- Temperature : 10~35°C
- Humidity : 50~60%RH

Note) If the module is left in an environment of 60 or more for a long period of time, optical characteristics may deteriorate.

(7) Storage method

If the LCD panel is damaged, do not inhale or allow the liquid crystal to enter the mouth

If the liquid crystal contacts the body or cloths, wash it off with soap immediately. Follow precautions for regular electronic components.

Solder flux on the printed circuit board is harmless to the quality and reliability of LCD module.

Fujitsu is practicing non-wash technology on module assembly process.

DOCUMENT CONTROL SECTION

DATE

						FLC43XWC8V-06A	
						Tech Bes LCD-00281	
						CUST.	
EDIT	DATE	DESIG.	CHECK	APPR.	DESCRIPTION		FUJITSU DISPLAY TECHNOLOGIES CORPORATION
DESIG.			CHECK		APPR.		35 /

(8) CAUTION IN DESIGNING INVERTER

A

Fluorescent lamps driven by high voltage are included in this LCD module. Please stand to the instructions below when designing inverter that lights the fluorescent lamps. Otherwise it may lead to FATAL FAILURE, such as SMOKING or FIRING.

A

APPLY PROTECTIVE CIRCUIT in preparation for lamp breaking, wire breaking and short circuit. The protective circuit should also detect half open circuit and wire breaking in narrow gap etc.. Otherwise it may lead to fatal failure.

B

KEEP ENOUGH CURRENT CAPACITY of inverter output for leakage current, which leaks from lamps and wire to surrounding metal material. Usually output current of about 1.5 times as same as the lamp current is necessary. But it sometimes varies due to characteristics of the inverter itself. So before determining design, please check characteristics of the inverter by connecting it to the LCD module.

B

KEEP ENOUGH TEMPERATURE MARGIN for each parts mounted on inverter. Temperature of the parts becomes higher when they are mounted in the final products due to heating inside. The temperature of each parts MUST NOT increase over the guaranteed temperature.

C

C

D

D

DOCUMENT CONTROL SECTION

DATE

E

F

						FLC43XWC8V-06A	
						Tech Bes LCD-00281	
						CUST.	
EDIT	DATE	DESIG.	CHECK	APPR.	DESCRIPTION		FUJITSU DISPLAY TECHNOLOGIES CORPORATION
DESIG.			CHECK		APPR.		36 /

18. PRECAUTIONS FOR USE

A

This Product is designed, developed and manufactured as contemplated for general use, including without limitation, general office use, personal use, household use, and ordinary industrial use, but is not designed, developed and manufactured as contemplated for use accompanying fatal risks or dangers that, unless extremely high safety is secured, could lead directly to death, personal injury, severe physical damage or other loss (hereinafter "High Safety Required Use"), including without limitation, nuclear reaction control in nuclear facility, aircraft flight control, air traffic control, mass transport control, medical life support system, missile launch control in weapon system. If customer's product possibly falls under the category of High Safety Required Use, please consult with our sales representatives in charge before such use. In addition, FDTC shall not be liable against the customer and/or any third party for any claims or damages arising in connection with the High Safety Required Use of the Product without permission.

A

B

B

19. MISCELLANEOUS

Specifications of the TFT-LCD panel and other components used in the LCD module are subject to change. Both parties shall discuss together before change.

C

If any doubt is raised in the content of the specifications, both parties shall discuss and make best effort for the agreement.

C

D

D

DOCUMENT CONTROL SECTION

DATE

						FLC43XWC8V-06A	
						Tech Bes LCD-00281	
						CUST.	
EDIT	DATE	DESIG.	CHECK	APPR.	DESCRIPTION		FUJITSU DISPLAY TECHNOLOGIES CORPORATION
DESIG.			CHECK		APPR.		37/

F

1 2 3 4 5 6 7 8

A
B
C
D
E

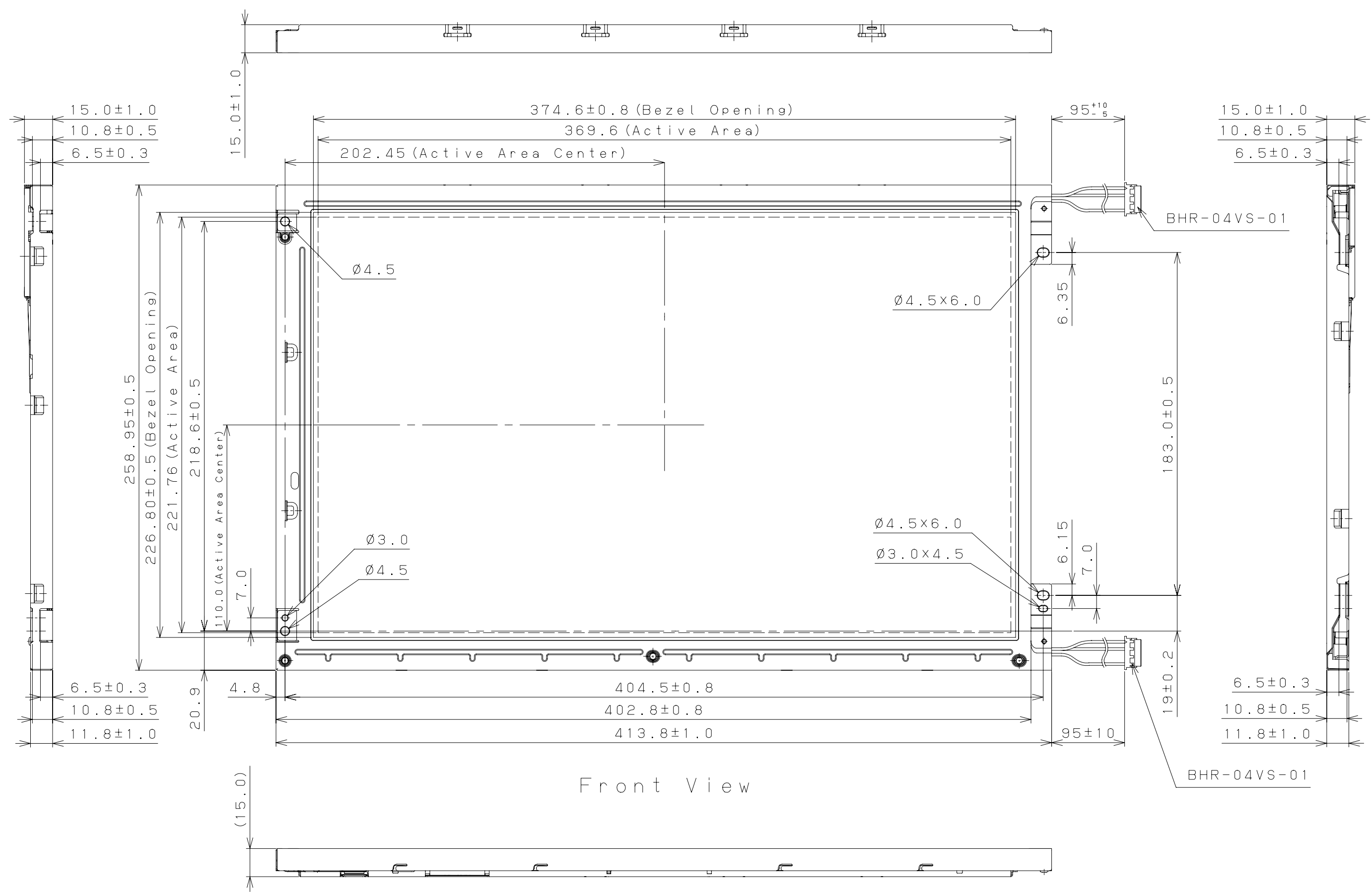

Front View

DATE DOCUMENT CONTROL SECTION

				TITLE FLC43XWC8V-06A	
				DRAW. NO. Tech Bes LCD-00281	
				CUST.	
EDIT.	DATE	DESIG.	CHECK	DESCRIPTION	
DESIG.			CHECK	APPR.	
				FUJITSU DISPLAY TECHNOLOGIES CORPORATION	
				38/	

1 2 3 4 5 6 7 8

A A

B B

C C

D D

E

F

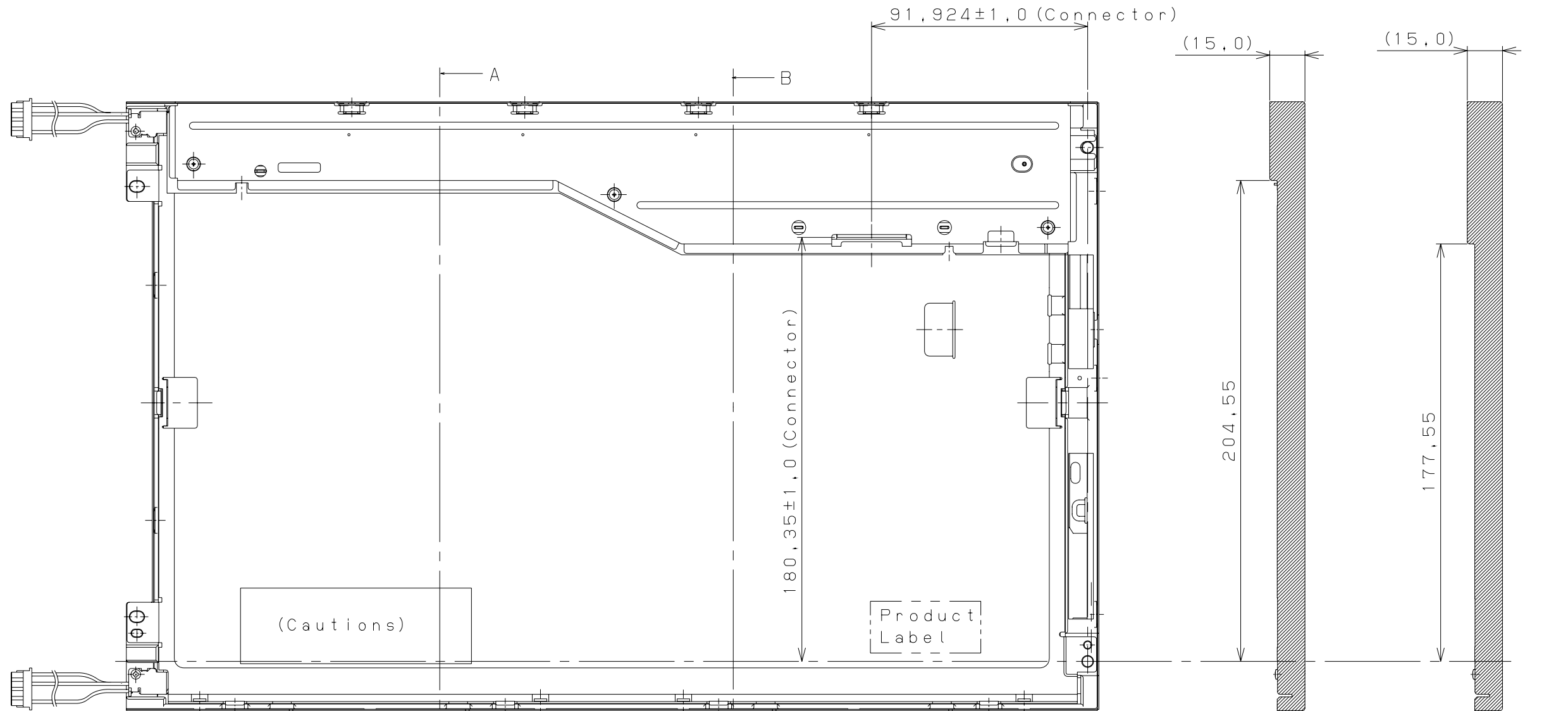

(Cautions)

Product Label

Rear View

DOCUMENT CONTROL SECTION

DATE

				TITLE		FLC43XWC8V-06A	
				DRAW. NO.		Tech Bes LCD-00281	
				CUST.			
EDIT.	DATE	DESIG.	CHECK	DESCRIPTION			
DESIG.			CHECK	APPR.	FUJITSU DISPLAY TECHNOLOGIES CORPORATION		
							39/39

1 2 3 4 5 6 7 8 93.04 FDN C39013