

TYPE SMTSO ReelFast™ SMT SPACERS/NUTS

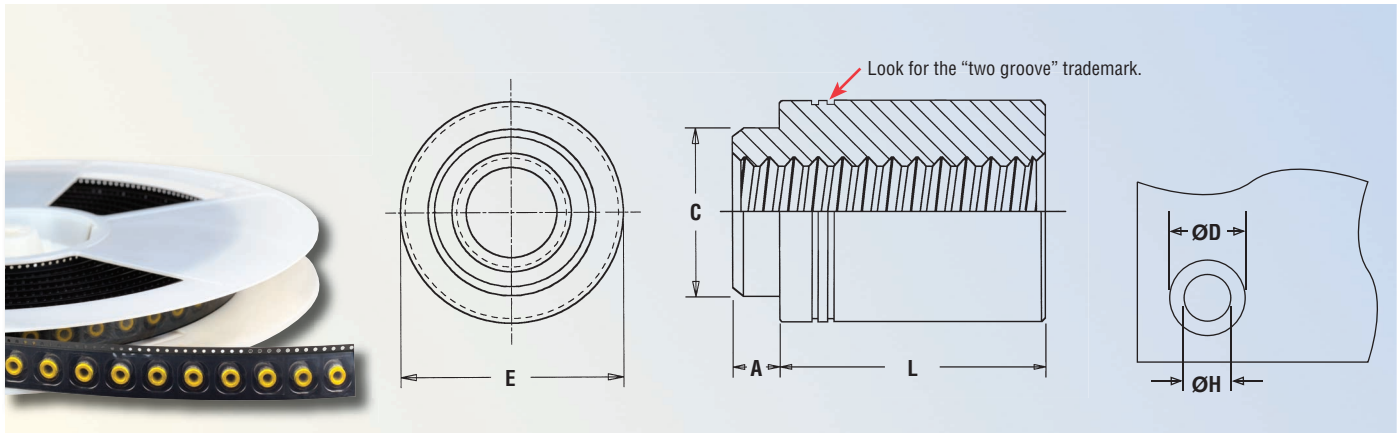

All dimensions are in inches.

UNIFIED	Thread Size	Thru Hole +.004 - .003	Type	Thread or Thru Hole Code	Length Code "L" ±.005 (Length code in 32nds of an inch)				Min. Sheet Thickness	A Max.	C Max.	E ±.005	ØH Hole Size In Sheet +.003 - .000	ØD Min. Solder Pad
					.065	.125	.250	.375						
	.112-40 (#4-40)	—	SMTSO	440	2	4	8	12	.060	.060	.161	.219	.166	.244
	.138-32 (#6-32)	—	SMTSO	632	2	4	8	12	.060	.060	.208	.281	.213	.306
	.164-32 (#8-32)	—	SMTSO	832	2	4	8	12	.060	.060	.245	.344	.25	.369
	—	.116	SMTSO	116	2	4	8	12	.060	.060	.161	.219	.166	.244
	—	.143	SMTSO	143	2	4	8	12	.060	.060	.208	.281	.213	.306

All dimensions are in millimeters.

METRIC	Thread Size x Pitch	Thru Hole +0.10 - 0.08	Type	Thread or Thru Hole Code	Length Code "L" ±0.13 (Length code in millimeters)						Min. Sheet Thickness	A Max.	C Max.	E ±0.13	ØH Hole Size In Sheet +0.08	ØD Min. Solder Pad
					2	3	4	6	8	10						
	M3 x 0.5	—	SMTSO	M3	2	3	4	6	8	10	1.53	1.53	4.09	5.56	4.22	6.2
	M3.5 x 0.6	—	SMTSO	M35	2	3	4	6	8	10	1.53	1.53	5.28	7.14	5.41	7.77
	M4 x 0.7	—	SMTSO	M4	2	3	4	6	8	10	1.53	1.53	6.27	8.74	6.4	9.37
	—	3.6	SMTSO	3.6	2	3	4	6	8	10	1.53	1.53	5.28	7.14	5.41	7.77
	—	4.2	SMTSO	4.2	2	3	4	6	8	10	1.53	1.53	6.27	8.74	6.4	9.37

Number Of Parts Per Reel For Each Size

Thread/Thru-Hole Size	Length Code						
	2	3	4	6	8	10	12
440, 632, 116, 143	1500	—	1000	—	650	—	300
832	1100	—	800	—	500	—	300
M3, M3.5, 3.6	1500	1000	900	650	375	300	—
M4, 4.2	1100	800	675	500	375	300	—

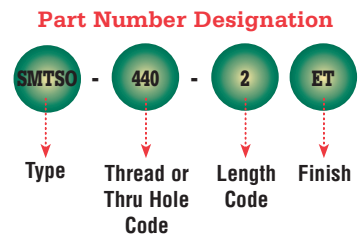

©Copyright 2004 PennEngineering.

Specifications subject to change without notice.

PennEngineering® Fastening Technologies

World Headquarters:
5190 Old Easton Road
Danboro, PA 18916 USA
E-mail: info@pennfast.com
Toll Free: 800-342-5736 (USA Only)
Tel: 215-766-8853 • Fax: 215-766-3633

U.K. And Europe:
Kirk Sandall Industrial Estate
Doncaster, South Yorkshire
DN3 1QR, England
E-mail: uk@pennfast.com
Tel: 01302 893100 • Fax: 01302 885341

Asia/Pacific:
Citipoint Industrial Complex
152 Paya Lebar Road #03-06
Singapore 409020
E-mail: arconix-sing@arconix.com
Tel: 6 745 0660 • Fax: 6 745 2400

Visit our PENNFAST™ Resource Center at www.pennfast.com

Printed in U.S.A.
CAGE-46384

Free Datasheet <http://www.datasheet4u.com/>