

PAL/NTSC encoder

TDA8501

FEATURES

- Two input stages: R, G, B and $-(R-Y)$, $-(B-Y)$, Y with multiplexing
- Chrominance processing, highly integrated, includes low frequency filters for the colour difference signals, and after the modulator a bandpass filter
- Fully controlled modulator produces a signal according to the PAL or NTSC standard without adjustments
- A free running oscillator. Can be tuned by crystal or by an external frequency source
- Output stages with separated Y + SYNC and chrominance (Y + C, SVHS), and a CVBS output. Signal amplitudes are correct for 75 Ω driving via an external emitter follower. Internal generation of NTSC setup
- Sync separator circuit and pulse shaper, to generate the required pulses for the processing, clamping, blanking, FH/2, and burst pulse
- H/2 control pin. In PAL mode the internally generated H/2 is connected to this pin and the phase of this signal can be reset
- Internal bandgap reference.

GENERAL DESCRIPTION

The TDA8501 is a highly integrated PAL/NTSC encoder IC which is designed for use in all applications where R, G and B or Y, U and V signals require transformation to PAL or NTSC values. the specification of the input signals are fully compatible with the specification of those of the TDA8505 SECAM-encoder.

ORDERING INFORMATION

EXTENDED TYPE NUMBER	PACKAGE			
	PINS	PIN POSITION	MATERIAL	CODE
TDA8501	24	DIL	plastic	SOT234AH2
TDA8501T	24	SO	plastic	SOT137AH1

PAL/NTSC encoder

TDA8501

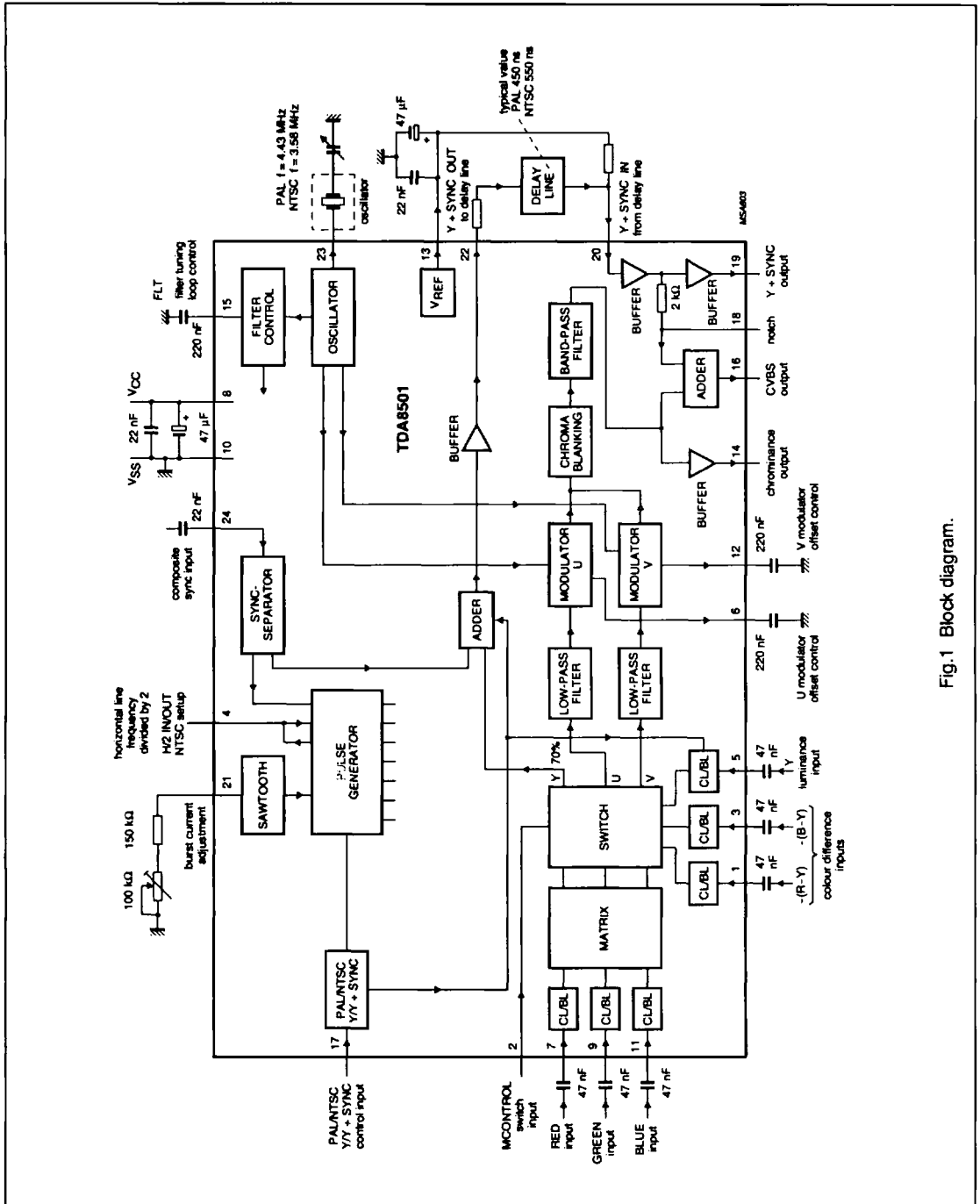

Fig.1 Block diagram.

PAL/NTSC encoder

TDA8501

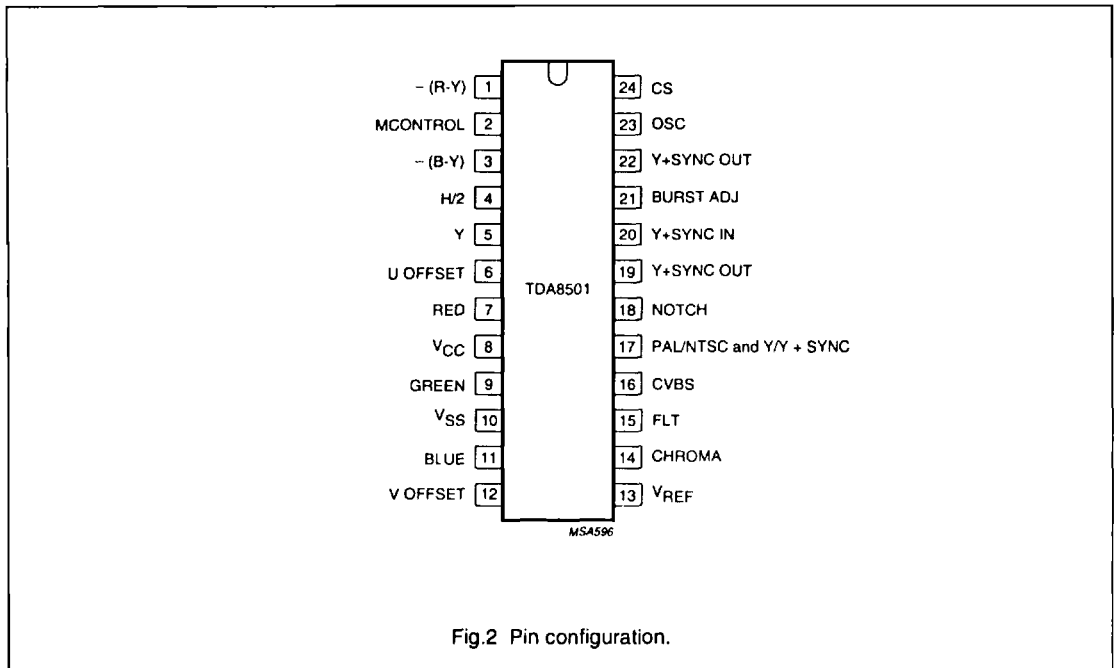

Fig.2 Pin configuration.

PINNING

U and V respectively, are the terms used to describe the colour difference signals at the output of the matrix.

SYMBOL	PIN	DESCRIPTION
-(R-Y)	1	colour difference input signal, for EBU bar (75%) 1.05 V (p-p)
MCONTROL	2	multiplexer switch control input; HIGH = RGB, LOW = -(R-Y), -(B-Y), Y
-(B-Y)	3	colour difference input signal, for EBU bar (75%) 1.33 V (p-p)
H/2	4	line pulse input/output divided-by-2 for synchronizing the internal H/2, if not used, this pin dependent on mode selected, is either left open-circuit, or connected to V _{CC} or to ground (note 1)
Y	5	luminance input signal 1 V nominal without sync
U OFFSET	6	U modulator offset control capacitor
R	7	RED input signal for EBU bar of 75% 0.7 V (p-p)
V _{CC}	8	supply voltage; 5 V nominal
G	9	GREEN input signal for EBU bar of 75% 0.7 V (p-p)
V _{SS}	10	ground (0 V)
B	11	BLUE input signal for EBU bar of 75% 0.7 V (p-p)
V OFFSET	12	V modulator offset control capacitor
V _{REF}	13	2.5 V internal reference voltage output
CHROMA	14	chrominance output
FLT	15	filter tuning loop capacitor

PAL/NTSC encoder

TDA8501

SYMBOL	PIN	DESCRIPTION
CVBS	16	composite PAL or NTSC output, 2 V (p-p) nominal
PAL/NTSC and Y/Y + SYNC	17	four level control pin (note 2)
NOTCH	18	Y + SYNC output via an internal resistor of 2 k Ω ; a notch filter can be connected to this pin
Y + SYNC OUT	19	2 V (p-p) nominal Y + SYNC output
Y + SYNC IN	20	Y + SYNC input; (from pin 22) connected to the output of the external delay line
BURST ADJ	21	burst current adjustment via external resistor
Y + SYNC OUT	22	Y + SYNC output 1 V (p-p) nominal, connected to the input of the external delay line
OSC	23	oscillator tuning: connected to either a crystal in series with capacitor to ground, or to an external frequency source via a resistor in series with a capacitor
CS	24	composite sync input, 0.3 V (p-p) nominal

Notes

- Pin 4: in PAL mode, if not connected to external H2 pulse, this pin is the output for the internally generated H/2 signal.
Pin 4: in NTSC mode, for internal set-up this pin is connected to ground; when internal set-up is switched off, this pin is connected to V_{CC} .
- The listed voltages connected to pin 17 (if $V_{CC} = +5\text{ V}$) enable the following Y (via pin 5) input signal states:
0 V = PAL mode; at pin 5, Y without sync and input blanking on
5 V = NTSC mode; at pin 5, Y without sync and input blanking on
1.8 V = PAL mode; at pin 5, Y with sync and input blanking off
3.2 V = NTSC mode; at pin 5, Y with sync and input blanking off

PAL/NTSC encoder

TDA8501

FUNCTIONAL DESCRIPTION

The TDA8501 device comprises:

- encoder circuit
- oscillator and filter control
- sync separator and pulse shaper.

Within this functional description, the term Y is used to describe the luminance signal and the terms U and V respectively, are used to describe the colour difference signals.

Encoder circuit**INPUT STAGE**

The input stage of the device uses two signal paths (see Fig.1). Fast switching between the two signal paths is achieved by means of the signal path selection switch MCONTROL (pin 2).

R, B AND G INPUT SIGNALS PATH

One signal path provides the connection for R, G and B signal inputs (via pins 7, 9 and 11) which are connected to a matrix via clamping and line blanking circuits. The signal outputs from the matrix are U, V and Y.

For an EBU colour bar of 75% the amplitude of the signal must be 0.7 V (peak-to-peak):

$$U = 0.493 (B-Y)$$

$$V = 0.877 (R-Y)$$

$$Y = 0.299 R + 0.587 G + 0.114 B$$

When selected (via MCONTROL), the U, V signals from the matrix are routed through the selection switch to the low pass filters. The Y signal from the matrix is routed through the selection switch to the adder and combined with the sync pulse from the sync separator and then connected via a buffer internally to pin 22 (Y + SYNC OUT to delay line).

-(R-Y), -(B-Y) AND Y INPUT SIGNALS PATH

A second signal path provides the connection for negative colour difference signal inputs -(R-Y), -(B-Y) i.e. V, U (via pins 1, 3) and luminance Y (via pin 5), which are routed directly to the switch inputs via clamping and line blanking circuits.

The Y input signal (via pin 5) differs from other signal inputs, in that the timing of the internal clamp is after the sync period.

The amplitude and polarity of these colour difference and luminance input signals are processed to provide suitable switch inputs of U, V and Y signal values.

The condition for 75% colour bar is:

$$\text{pin 1} \quad -(R-Y) = 1.05 \text{ V (peak-to-peak)}$$

$$\text{pin 3} \quad -(B-Y) = 1.33 \text{ V (peak-to-peak)}$$

$$\text{pin 5} \quad Y = 1 \text{ V (peak-to-peak) without sync}$$

When selected (via MCONTROL), the U and V signals (via the switch) are routed to the low pass filters. The Y signal (via the switch) is routed via the adder and buffer to pin 22 (Y + SYNC OUT to delay line). Dependent on pin 17 conditioning, the Y signal may have external or internal sync added (see section Four level control pin).

FOUR LEVEL CONTROL PIN

The Y input signal (via pin 5) is conditioned by use of the 4-level control pin (pin 17) to emulate either the PAL or NTSC modes, with sync and input blanking off or without sync and input blanking on.

Pin 17 may be hard wire connected to either ground (LOW for PAL mode) or V_{CC} (HIGH for NTSC mode). External resistors can further modify the voltage level input at pin 17 to condition (pin 5) Y with sync and input blanking off or Y without sync and input blanking on. (see section PAL/NTSC and Y/Y + SYNC).

U AND V SIGNALS

In PAL and NTSC modes the U and V (colour difference) signals at the output of the switch are configured differently as follows:

PAL mode:

- after the adding of the burst pulse to U and V, these signals are connected to the input of the low pass filters. During the vertical sync period the burst pulse is suppressed.

NTSC mode:

- the burst pulse is only added to U and the gain of the U and V signals is 0.95 of the gain in PAL mode. During the vertical sync period the burst pulse is suppressed.

LOW PASS FILTERS

The -3dB nominal frequency response level of the low pass filters are different in PAL and NTSC modes.

PAL/NTSC encoder

TDA8501

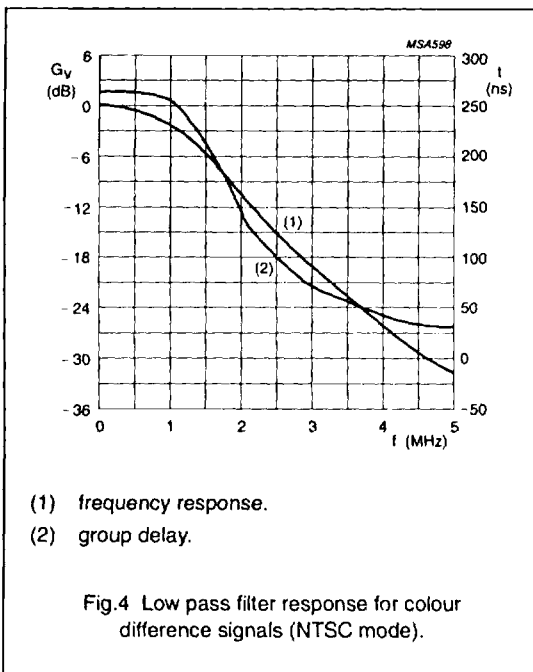
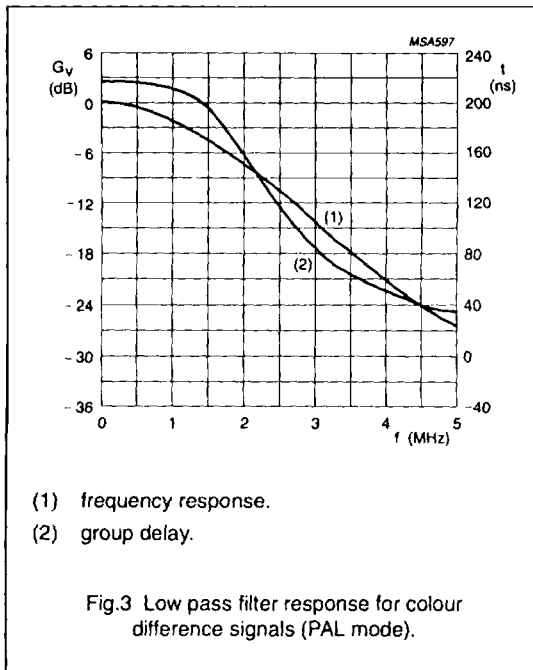

PAL mode: bandwidth = 1.35 MHz nominal (see Fig.3).
NTSC mode: bandwidth = 1.1 MHz nominal (see Fig.4).

The signal outputs of the low pass filters are connected to the signal inputs of the U and V modulators.

U AND V MODULATORS

Two four-quadrant multipliers are used for quadrature amplitude modulation of the U and V signals. The level of harmonics produced by the modulated signals are minimal, because of real multiplication with sinewave carriers.

The unbalance of the modulators is minimized by means of a control loop and two external capacitors, pin 6 for the U modulator and pin 12 for the V modulator. The timing of the control loop is triggered by the H/2 pulse, so that during one sync period the U control is active and during the next sync period the V control is active. In this way, when U and V are both zero, the suppressed carrier is guaranteed to be at a low level.

The internal oscillator circuit generates two sinewave carriers (0 degree and 90 degree). The '0 degree' (0) carrier is connected to the U modulator and the '90 degree' (1) carrier is connected to the V modulator.

PAL mode:

- switched sequentially by the H/2 pulse, the V signal is modulated alternately with the direct and inverse carrier.
- the internal H/2 pulse can be forced into a specific phase by means of an external pulse connected to pin 4 (H/2). Forcing is active at HIGH level. If not used pin 4 can be left open-circuit or connected to ground. If pin 4 is left open, the internally generated H/2 pulse (output) is connected to this pin.

NTSC mode:

- alternation of the V modulation is not allowed. If pin 4 is not used for set-up control (see Y + SYNC, CVBS and Chrominance outputs), it can be left open-circuit or connected to ground.

CHROMINANCE BLANKING

The signal outputs from the modulators are connected to the signal input of the chrominance blanking circuit. To avoid signal distortion that may be caused by the control loop, the signal outputs of the modulators are blanked during the sync period. This prevents signal distortion during the adding of the sync pulse at the CVBS output circuit.

PAL/NTSC encoder

TDA8501

BANDPASS FILTER

A wide symmetrical bandpass filter is used so that a maximum performance of the chrominance for Y + C (SVHS) is guaranteed. This wide curve is possible because of the minimal signal level of the harmonics within the modulators see Figs (PAL mode: 5 and 6); (NTSC mode: 7 and 8) which illustrate the nominal response for PAL and NTSC modes.

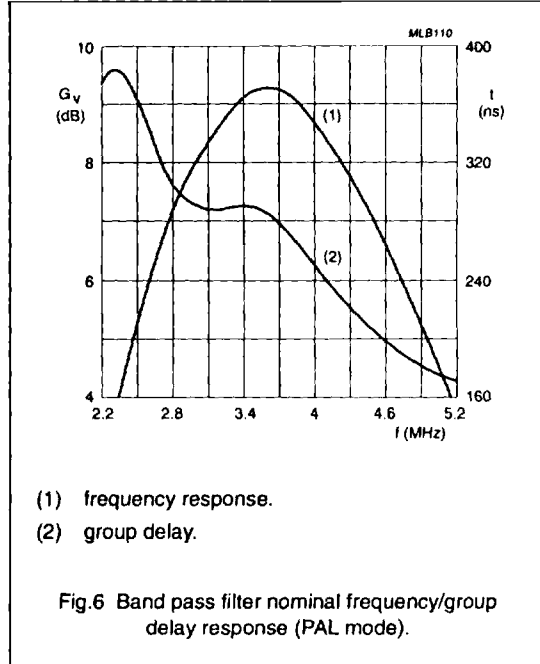
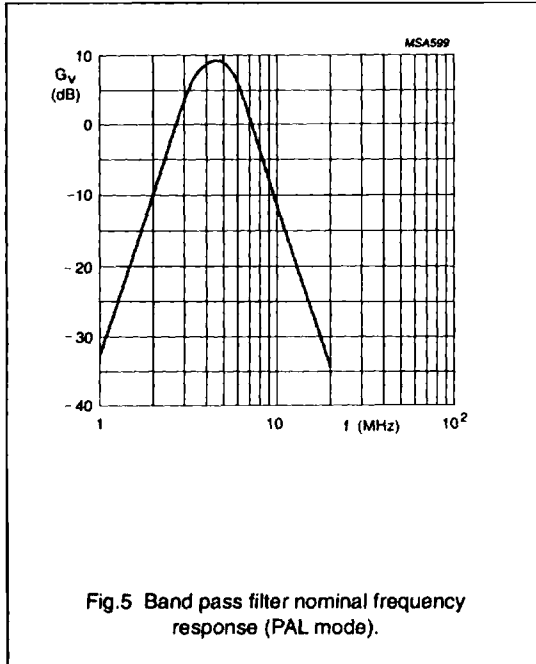

PAL/NTSC encoder

TDA8501

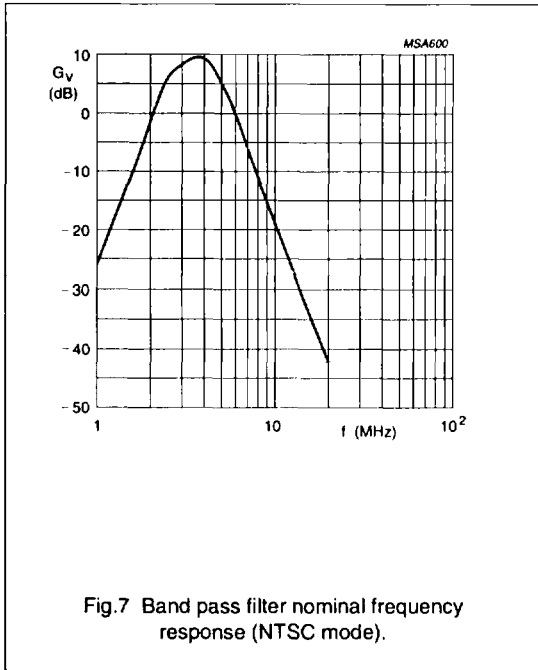
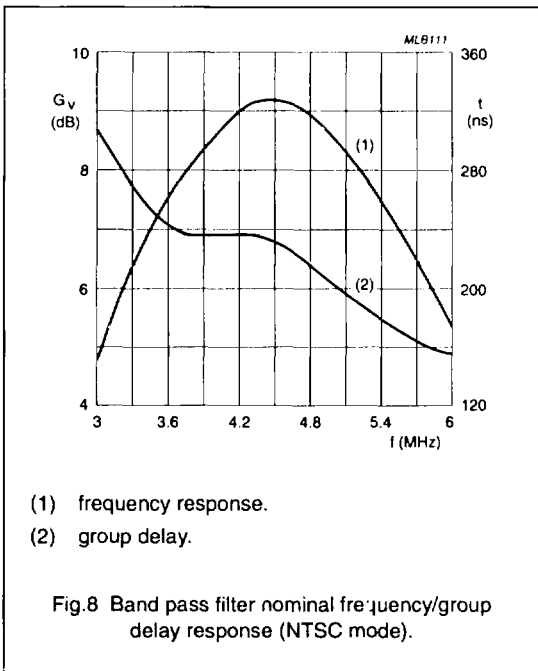

Fig.7 Band pass filter nominal frequency response (NTSC mode).



- (1) frequency response.
- (2) group delay.

Fig.8 Band pass filter nominal frequency/group delay response (NTSC mode).

Y + SYNC, CVBS AND CHROMINANCE OUTPUTS

The Y signal from the matrix, or the Y signal from pin 5, (selected via the switch) is added with the composite sync signal of the sync separator (dependent on pin 17 conditioning). The output of the adder, nominal 1 V (peak-to-peak), is connected to pin 22 (see Fig.1). Pin 22 is connected to an external delay line.

The delay line is necessary for correct timing of the Y + SYNC signal with the chrominance signal. The output resistor of the delay line is connected to V_{REF} (pin 13). The output of the external delay line is connected to (input) pin 20.

The Y + SYNC (delayed) input signal at pin 20 is amplified via a buffer to a level of 2 V (peak-to-peak) nominal and connected to pin 19 (Y + SYNC output).

The Y + SYNC (delayed) input signal at pin 20 is also connected via an internal resistor of 2 k Ω to the input of the CVBS adder stage. After the internal resistor of 2 k Ω , and before the input of the CVBS adder, an external notch filter can be connected via pin 18.

The chrominance output of the bandpass filter is added with Y + SYNC signal via the CVBS adder. The CVBS (combined video and blanking signal) output of the adder is connected to pin 16 with a nominal amplitude of 2 V (peak-to-peak).

The chrominance output of the bandpass filter is amplified via a buffer and connected to pin 14. The chrominance amplitude corresponds with the value of Y + SYNC signal output at pin 19. Together both outputs give the Y + C (SVHS) signals.

BLACK AND BLANKING LEVELS IN PAL AND NTSC MODES

PAL mode: Fig.9 illustrates the nominal Y + SYNC signal at pin 22, the difference between black and blanking level is 0 mV.

NTSC mode: Fig.10 illustrates the nominal Y + SYNC signal at pin 22, the difference between black and blanking level is 53 mV.

Because of the difference between the black and blanking level in the NTSC mode, there are two options for NTSC.

PAL/NTSC encoder

TDA8501

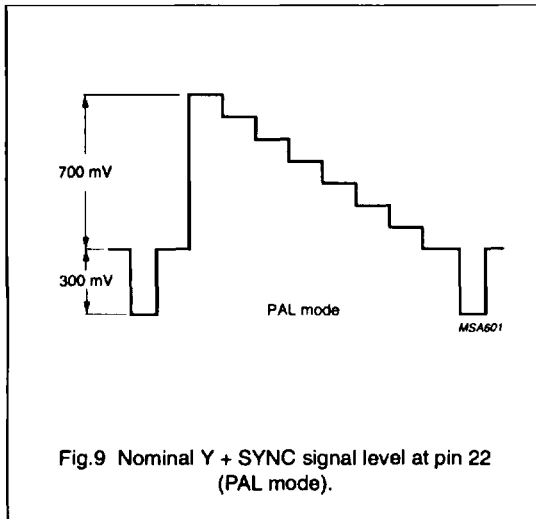

Fig.9 Nominal Y + SYNC signal level at pin 22 (PAL mode).

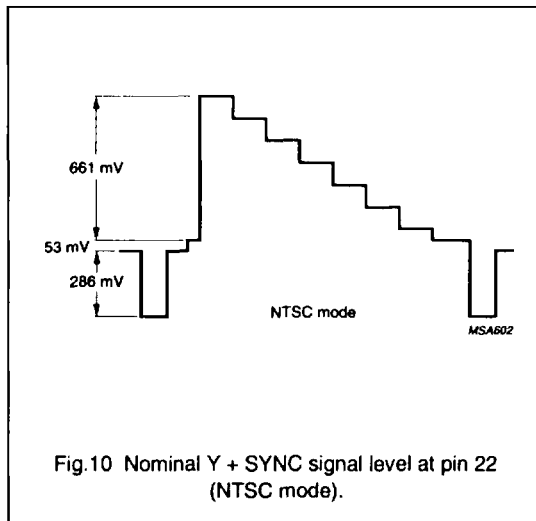

Fig.10 Nominal Y + SYNC signal level at pin 22 (NTSC mode).

NTSC option with internal set-up generation

Pin 4 connected to ground or left open-circuit. The set-up is generated internally and the input signals have the values already specified in section Input stage. The set-up is not suppressed during vertical sync.

NTSC option without internal set-up generation

Pin 4 connected to V_{CC} . This option places some restrictions on the input signals as follows:

- if the output signal must be according to the NTSC standard, the input signals must be generated with a specific set-up level
- for R, G and B inputs a set-up level of 53 mV is required, therefore the specified amplitude must be 753 mV (peak-to-peak) instead of 700 mV (peak-to-peak)
- for U, V and Y inputs a set-up level for Y of 76 mV is required, therefore the specified amplitude must be 1076 mV (peak-to-peak) (without sync) instead of 1 V (peak-to-peak). This option, combined with U, V and Y inputs, is not possible if V_{CC} is < 4.75 V.

PAL/NTSC encoder

TDA8501

Oscillator and Filter Control

The internal crystal oscillator is connected to pin 23 which provides for the external connection of a crystal in series with a trimmer to ground. It is possible to connect an external signal source to pin 23, via a capacitor in series with a resistor. The signal shape is not important. Figure 11 shows the external components connected to pin 23 and the required conditions. The minimum AC current of 50 μ A must be determined by the resistors (R_{int} and R_{ext}) and the voltage of the signal source. For example, in this way an external sub-carrier, locked to the sync, can be used.

PAL mode: frequency of the oscillator is 4.433618 MHz.

NTSC mode: frequency of the oscillator is 3.579545 MHz.

The -3 dB of the low pass filters and the centre frequency of the bandpass filter are controlled by the filter control loop and directly coupled to the value of the frequency of the oscillator. The external capacitor of the control loop is connected to pin 15.

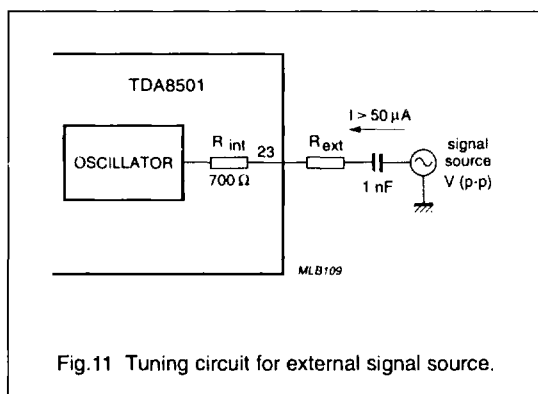

Fig.11 Tuning circuit for external signal source.

Sync separator and Pulse shaper

The composite sync (CS) input at pin 24 (via the sync separator) together with a sawtooth generator provide the source for all pulses necessary for the processing.

Pulses are used for:

- clamping
- video blanking
- H/2
- chrominance blanking
- burst pulse generation for adding to U, V
- pulses for the modulator offset control.

The value of the sawtooth generator output (current) is determined by the value of a fixed resistor to ground which is connected externally at pin 21 (BURST ADJ). When finer tolerance of the burst position is required, the fixed resistor is connected in series with a variable potentiometer to ground. By use of the potentiometer the burst position at the outputs can be finely adjusted, after which the pulse width of the burst and the position and pulse width of all other internal pulses are then determined. When using a fixed resistor with a tolerance of 2%, a tolerance of 10% of the burst position can be expected. Timing diagrams of the pulses are provided by Figs 12 and 13.

H/2 at pin 4 is only necessary in the PAL mode when the internal H/2 pulse requires locking with an external H/2 phase (two or more encoders locked in same phase). The forcing of the internal H/2 to a desired phase is possible by means of an external pulse. Forcing is active at HIGH level.

For the functioning of Pin 4 in the NTSC mode see also section Black and Blanking levels in PAL and NTSC modes.

PAL/NTSC encoder

TDA8501

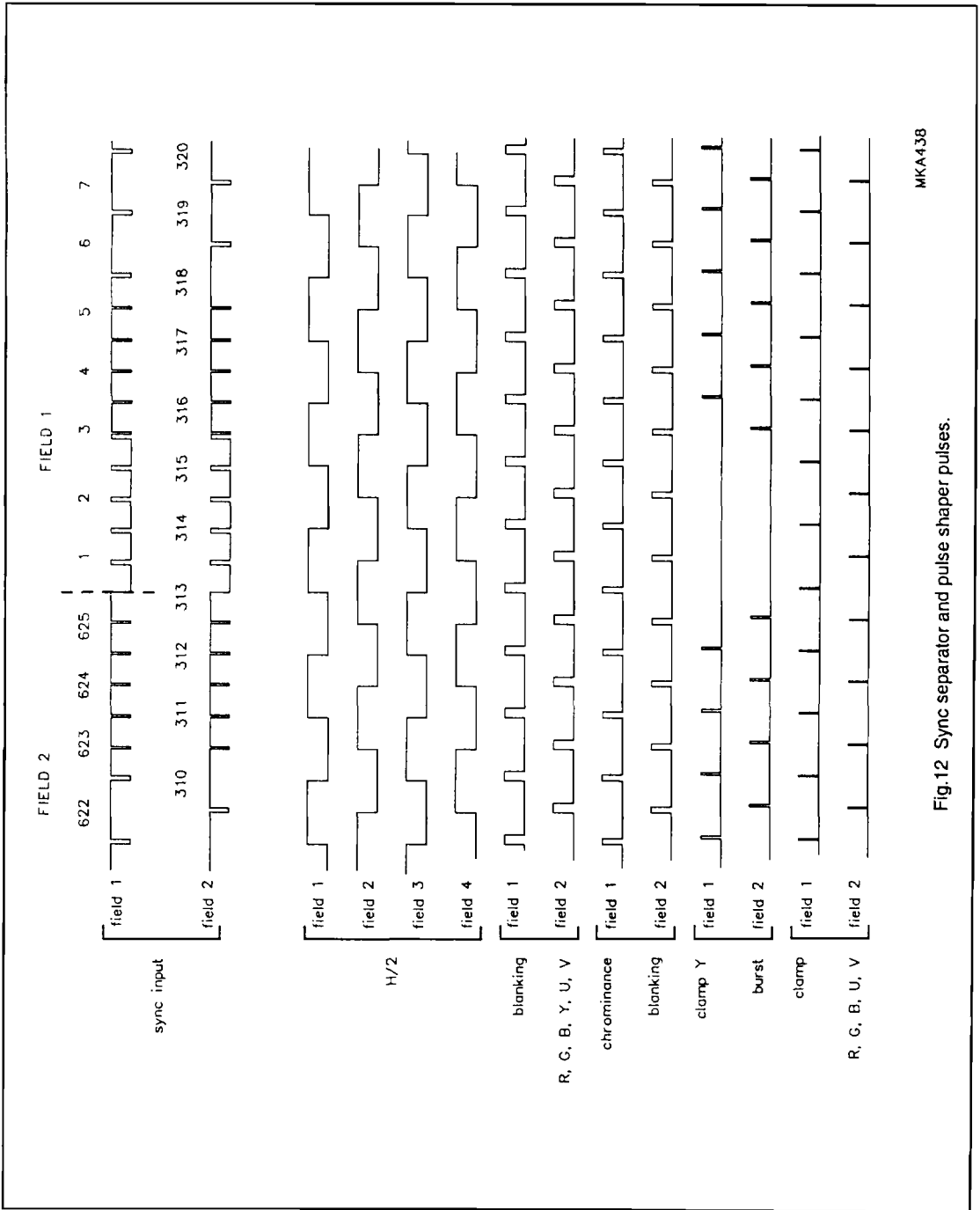
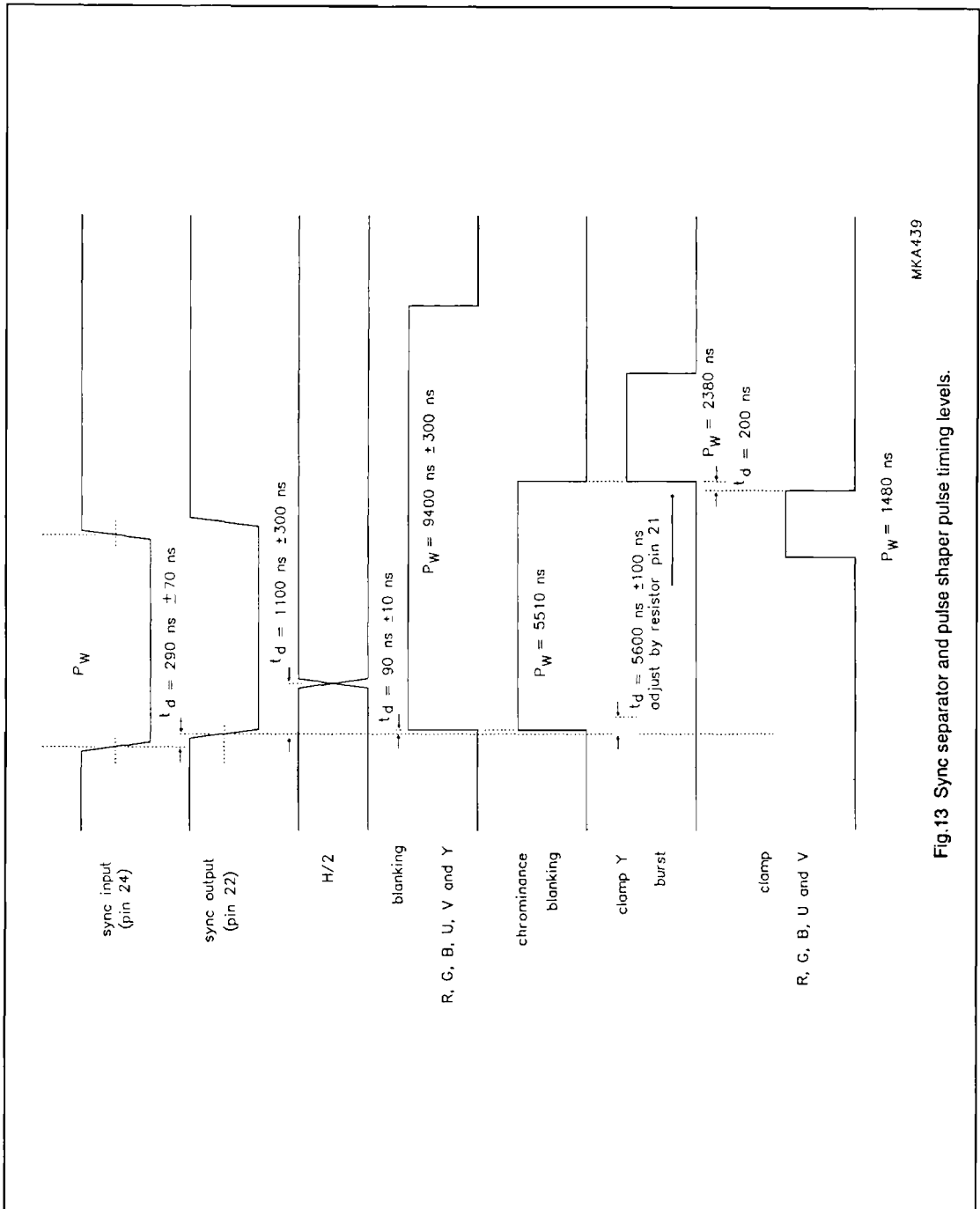

Fig.12 Sync separator and pulse shaper pulses.

PAL/NTSC encoder

TDA8501



MKA439

Fig.13 Sync separator and pulse shaper pulse timing levels.

PAL/NTSC encoder

TDA8501

PAL/NTSC and Y/Y + SYNC

Pin 17 is used as a four level control pin to condition the Y/Y + SYNC input signal (via pin 5). Pin 17 is normally connected to ground for PAL mode, or to V_{CC} for the NTSC mode. By use of external resistors (potential divider connected to pin 17), the input blanking at pin 5 can be switched on and off. (see Table 1 and Fig 14).

Table 1 PAL/NTSC Y/Y + SYNC pin 5 options (pin 17 connection configurations).

MODE	PIN 5 STATUS	PIN 17 CONNECTION REQUIREMENT
PAL	Y without sync and input blanking on	pin 17 LOW, connected to V_{SS}
NTSC	Y without sync and input blanking on	pin 17 HIGH, connected to V_{CC}
PAL	Y with sync and input blanking off	pin 17 with 39 k Ω connected to V_{CC} and 22 k Ω connected to V_{SS}
NTSC	Y with sync and input blanking off	pin 17 with 22 k Ω connected to V_{CC} and 39 k Ω connected to V_{SS}

LIMITING VALUES

In accordance with the Absolute Maximum System (IEC134); all voltages referenced to V_{SS} (pin 10).

SYMBOL	PARAMETER	MIN.	MAX.	UNIT
V_{CC}	positive supply voltage	0	5.5	V
T_{sig}	storage temperature	-65	+150	$^{\circ}$ C
T_{amb}	operating ambient temperature	-25	+70	$^{\circ}$ C

THERMAL RESISTANCE

SYMBOL	PARAMETER	THERMAL RESISTANCE
$R_{th j-a}$	from junction to ambient in free air SOT234 SOT137	66 K/W 75 K/W

DC CHARACTERISTICS

$V_{CC} = 5$ V; $T_{amb} = 25$ $^{\circ}$ C; all voltages referenced to ground (pin 10); unless otherwise specified.

SYMBOL	PARAMETER	CONDITIONS	MIN.	TYP.	MAX.	UNIT
Supply (pin 8)						
V_{CC}	supply voltage		4.5	5.0	5.5	V
I_{CC}	supply current		-	40	-	mA
P_{tot}	total power dissipation		-	200	-	mW
V_{REF}	reference voltage output (pin 13)		2.425	2.5	2.575	V

PAL/NTSC encoder

TDA8501

AC CHARACTERISTICS

 $V_{CC} = 5\text{ V}$; $T_{amb} = 25\text{ }^{\circ}\text{C}$; composite sync signal connected to pin 24; unless otherwise specified.

SYMBOL	PARAMETER	CONDITIONS	MIN.	TYP.	MAX.	UNIT
Encoder circuit						
Input stage (pins 1, 3, 5, 7, 9 and 11); black level = clamping level						
$V_{r(max)}$	maximum signal from black level positive		–	1.2	–	V
$V_{r(min)}$	from black level negative	only pins 1, 3 and 5	–	0.9	–	V
I_{bias}	input bias current	$V_i = V_{i3}$	–	–	< 1	μA
V_i	input voltage clamped	input capacitor connected to ground	tbf	V_{i3}	tbf	V
$ Z_i $	input clamping impedance	$I_i = 1\text{ mA}$ $I_o = 1\text{ mA}$	–	80	–	Ω
	matrix and gain tolerance of R, G and B signals		–	–	< 5	%
G	gain tolerance of Y, $-(R-Y)$ and $-(B-Y)$		–	–	< 5	%
MCONTROL (pin 2; note 1)						
V_{L}	LOW level input voltage Y, $-(R-Y)$ and $-(B-Y)$		0	–	0.4	V
V_{H}	HIGH level input voltage R, G and B		1	–	5	V
I_i	input current		–	–	–3	μA
t_{sw}	switching time		–	50	–	ns
U modulator offset control (pin 6)						
V_6	DC voltage control level		–	2.5	–	V
I_{LI}	input leakage current		–	–	100	nA
V_{LL}	limited level voltage LOW		–	1.8	–	V
V_{HL}	limited level voltage HIGH		–	3.2	–	V
V modulator offset control (pin 12)						
V_{12}	DC voltage control level		–	2.5	–	V
I_{LI}	input leakage current		–	–	100	nA
V_{LL}	limited level voltage LOW		–	1.8	–	V
V_{HL}	limited level voltage HIGH		–	3.2	–	V
Y + SYNC (pin 22 out to delay circuit)						
R_O	output resistance		–	–	< 25	Ω
I_{sink}	maximum sink current		350	–	–	μA
I_{source}	maximum source current		1000	–	–	μA
V_{BL}	black level output voltage		–	2.5	–	V

PAL/NTSC encoder

TDA8501

SYMBOL	PARAMETER	CONDITIONS	MIN.	TYP.	MAX.	UNIT
PAL mode; pin 17 = 0 V						
V_{SYNC}	sync voltage amplitude		285	300	315	mV
V_Y	Y voltage amplitude		665	700	735	mV
V_{DIF}	difference between black and blanking level		–	0	–	mV
NTSC mode; pin 17 = 5 V and pin 4 open-circuit or ground						
V_{SYNC}	sync voltage amplitude		270	286	300	mV
V_Y	Y voltage amplitude		628	661	694	mV
V_{DIF}	difference between black and blanking level		–	53	–	mV
BW	frequency response	pin 22 with external load of $R = 10 \text{ k}\Omega$ and $C = 10 \text{ pF}$	10	–	–	MHz
	group delay tolerance		–	–	20	ns
t_d	sync delay from pin 24 to pin 22		220	290	360	ns
t_d	Y delay from pin 5 to pin 22		–	10	–	ns
α	Chrominance cross talk	0 dB = 1330 mV (peak-to-peak) = 75% RED	–	–	–60	dB
Y + SYNC IN (pin 20 from delay circuit; note 2)						
I_{bias}	input bias current		–	–	1	μA
V_i	maximum voltage amplitude		–	–	1	V
Y + SYNC OUT (pin 19 output Y (SVHS); note 2)						
R_O	output resistance		–	120	–	ω
I_{sink}	maximum sink current		650	–	–	μA
I_{source}	maximum source current		1000	–	–	μA
V_{BL}	black level output voltage		–	1.65	–	V
G	Y + SYNC gain; from pin 20 to pin 19		–	12	–	dB
BW	frequency response	pin 19 with external load of $R = 10 \text{ k}\Omega$ and $C = 10 \text{ pF}$	10	–	–	MHz
	group delay tolerance		–	–	20	ns
α	Chrominance cross talk	0 dB = 1330 mV (peak-to-peak) = 75% RED	–	–	–54	dB

Notes

1. The threshold level of this pin is 700 mV \pm 20 mV. The specification of the HIGH and LOW levels is according to the SCART fast blanking.
2. Pin 20 condition: black level of input signal must be 2.5 V; amplitude 0.5 V (peak-to-peak) nominal.

PAL/NTSC encoder

TDA8501

AC CHARACTERISTICS (continued)

SYMBOL	PARAMETER	CONDITIONS	MIN.	TYP.	MAX.	UNIT
NOTCH (pin 18)						
R_o	output resistance		1750	2000	2500	Ω
V_{CC}	DC voltage level		–	2.5	–	V
I_{sink}	maximum sink current		350	–	–	μA
Chrominance output (pin 14)						
I_{sink}	maximum sink current		700	–	–	μA
I_{source}	maximum source current		1000	–	–	μA
R_o	output resistance		–	120	–	Ω
ΔV_{DC}	variation of DC voltage level when chrominance signal is blanked and chrominance signal is not blanked		–	–	5	mV
PAL mode; pin 17 = 0 V						
V_o	chrominance output voltage (peak-to-peak) amplitude burst ratio: chrominance (75% RED)/burst		480 2.1	600 2.2	720 2.3	mV
NTSC mode; pin 17 = 5 V						
V_o	chrominance output voltage (peak-to-peak) amplitude burst ratio: chrominance (75% RED)/burst		460 2.1	570 2.2	680 2.3	mV
	carrier suppression when input-signals are 0 V	0 dB = 1330 mV (peak-to-peak)	–	37	–	dB
	phase accuracy (difference between 0 and 90 degree carriers)		–	–	2	degrees
LPF	Low-pass filters	see Figs 3 and 4				
BPF	Band-pass filters	see Figs 5 and 6				
V_n	noise level (RMS value)		–	–	4	mV
BP	burst phase; 0 degrees = phase U carrier					
	PAL mode NTSC mode		– –	± 135 180	– –	degrees degrees
α	Y + SYNC cross talk (0 to 6 MHz)	0 dB = 1400 mV (peak-to-peak)	–	–	–60	dB

PAL/NTSC encoder

TDA8501

SYMBOL	PARAMETER	CONDITIONS	MIN.	TYP.	MAX.	UNIT
CVBS output (pin 16)						
I_{sink}	maximum sink current		650	–	–	μA
I_{source}	maximum source current		1000	–	–	μA
V_{O}	DC voltage level	$Y + \text{SYNC} = 0$	–	1.6	–	V
G	Y + SYNC gain; from pin 20 to pin 16		–	12	–	dB
G	chrominance difference; from pin 14 to pin 16		–	0	–	dB
G_{e}	differential phase	note 1	–	–	3	degrees
G_{v}	differential gain	note 2	–	–	3	dB
R_{O}	output resistance		–	120	–	Ω
Oscillator output (pin 23)						
OSC	series-resonance	the resonance resistance of the crystal should be $< 60 \Omega$ and the parallel capacitance of the crystal should be $< 10 \text{ pF}$.				
Filter tuning loop (pin 15)						
V_{DC}	DC control voltage level NTSC		–	0.83	–	V
V_{DC}	DC control voltage level PAL		–	0.88	–	V
V_{OCL}	limited DC-level LOW	$I_{\text{O}} = 200 \mu\text{A}$	–	0.27	–	V
V_{DCH}	limited DC-level HIGH	$I_{\text{I}} = 200 \mu\text{A}$	–	1.8	–	V
H2 (pin 4)						
V_{L}	LOW level input voltage	inactive	0	–	1	V
V_{IH}	HIGH level input voltage	active	4	–	5	V
I_{I}	current for forcing HIGH		220	–	–	μA
I_{O}	current for forcing LOW		260	–	–	μA
V_{O}	voltage out LOW		–	–	< 0.5	V
V_{O}	voltage out HIGH		4	–	–	V
I_{sink}	maximum sink current		50	–	–	μA
I_{source}	maximum source current		50	–	–	μA
Composite sync input (pin 24)						
V_{SYNC}	SYNC pulse amplitude		75	300	600	mV(p-p)
	slicing level		–	50	–	%
I_{I}	input current		–	4	–	μA
I_{O}	maximum output current during SYNC		–	100	–	μA
BURST ADJ (pin 21; note 3)						
BP	DC voltage level		–	V_{REF} (V13)	–	V

PAL/NTSC encoder

TDA8501

SYMBOL	PARAMETER	CONDITIONS	MIN.	TYP.	MAX.	UNIT
Control pin PAL/NTSC and Y/Y + SYNC (pin 17; note 4)						
V _I	PAL mode and blanking pin 5 active internal sync added to Y		0	–	1	V
V _I	PAL mode and blanking pin 5 inactive internal sync not added to Y		1.6	–	2.0	V
V _I	NTSC mode and blanking pin 5 active internal sync added to Y		4	–	5	V
V _I	NTSC mode and blanking pin 5 inactive internal sync not added to Y		3	–	3.4	V
I _{bias}	input bias current		–	–	–10	μA

Notes

1. Definition: *maximum phase – minimum phase = difference phase*
2. Definition: $\frac{\text{maximum gain} - \text{minimum gain}}{\text{maximum gain}} \times 100 = \text{difference gain \%}$
3. The output impedance of this pin is low (< 100 Ω). The nominal value of the external resistor is 196 kΩ (see also section Sync separator and Pulse shaper).
4. The threshold levels are: 0.25 times V_{CC}, 0.5 times V_{CC} and 0.75 times V_{CC}.

PAL/NTSC encoder

TDA8501

Table 2 Internal circuitry.

PIN	NAME	CIRCUIT	DESCRIPTION
1	-(R-Y)		<p>-(R-Y) input; connected via 47 nF capacitor 1.05 V (p-p) for EBU bar of 75% see also pins 3, 5, 7, 9 and 11</p>
2	MCONTROL		<p>multiplexer switch control input < 0.4 V Y, U and V > 1 V R, G and B</p>
3	-(B-Y)	<p>see pin 1</p>	<p>-(B-Y) input; connected via 47 nF capacitor 1.33 V (p-p) for EBU bar of 75%</p>
4	H/2 IN/OUT		<p>H/2 input PAL MODE: pin open, output of internal H/2 Forcing possibility NTSC mode: 0 V set-up 5 V no set-up</p>

PAL/NTSC encoder

TDA8501

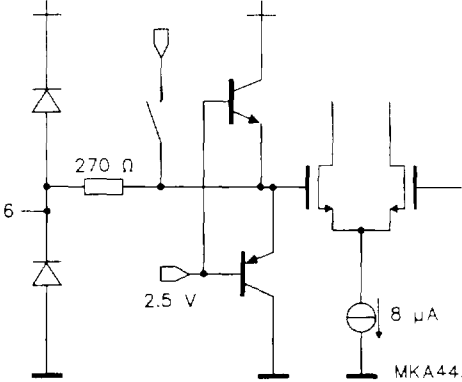
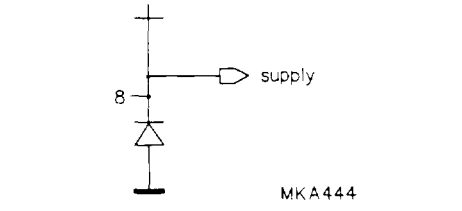
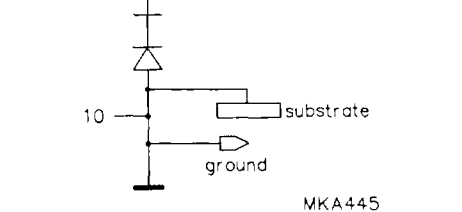
PIN	NAME	CIRCUIT	DESCRIPTION
5	Y	see pin 1	Y input; connected via 47 nF capacitor 1 V (p-p) for EBU bar of 75%
6	U OFFSET		220 nF (low-leakage) connected to ground see also pin 12
7	R	see pin 1	RED input; connected via 47 nF capacitor 0.7 V (p-p) for EBU bar of 75%
8	V _{CC}		supply voltage 5 V nominal
9	G	see pin 1	GREEN input; connected via 47 nF capacitor 0.7 V (p-p) for EBU bar of 75%
10	V _{SS}		ground
11	B	see pin 1	BLUE input; connected via 47 nF capacitor 0.7 V (p-p) for EBU bar of 75%

PAL/NTSC encoder

TDA8501

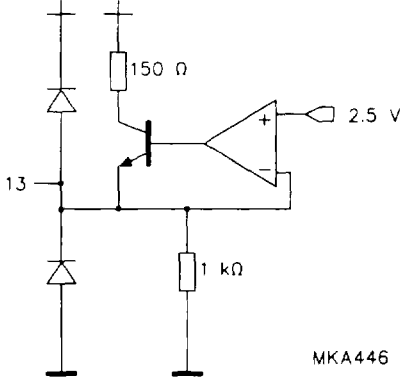
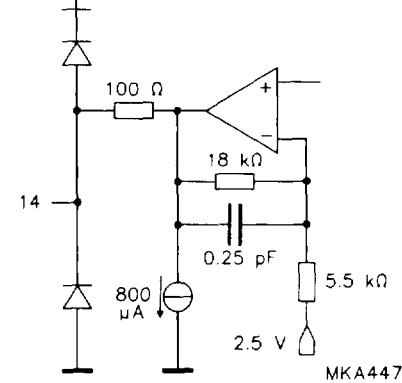
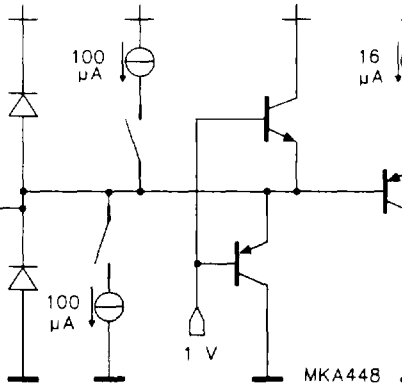
PIN	NAME	CIRCUIT	DESCRIPTION
12	V OFFSET	see pin 6	220 nF (low-leakage) connected to ground
13	V_{REF}		2.5 V reference voltage decoupling with 47 μ F and 22 nF capacitors
14	CHROMA		chrominance output; together with pin 19 the Y + C (SVHS) output
15	FLT		filter control pin 220 nF capacitor to ground

PAL/NTSC encoder

TDA8501

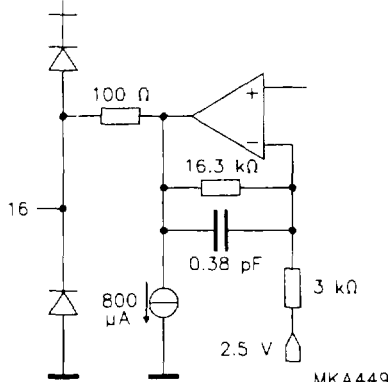
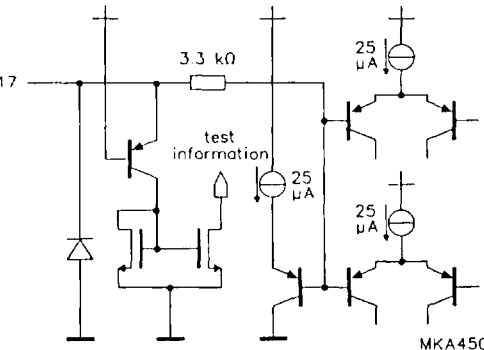
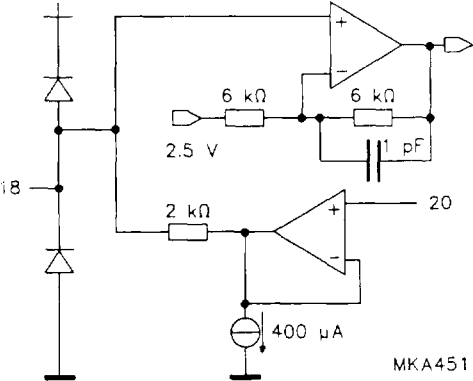
PIN	NAME	CIRCUIT	DESCRIPTION
16	CVBS	 <p>MKA449</p>	CVBS output
17	PAL/NTSC Y/Y + SYNC	 <p>MKA450</p>	4-level control pin Pin 5: 0 V PAL, Y 1.8 V PAL Y + SYNC 3.2 V NTSC Y + SYNC 5 V NTSC Y
18	NOTCH	 <p>MKA451</p>	pin for external notch filter

PAL/NTSC encoder

TDA8501

PIN	NAME	CIRCUIT	DESCRIPTION
19	Y + SYNC OUT		output of the Y + SYNC signal; together with pin 14 the Y + C (SVHS) output
20	Y + SYNC IN		input of the delayed Y + SYNC signal of the delay line black level must be 2.5 V
21	BURST ADJ		external resistor to ground for adjusting the position of the burst

PAL/NTSC encoder

TDA8501

PIN	NAME	CIRCUIT	DESCRIPTION
22	Y + SYNC OUT	<p style="text-align: right;">MKA455</p>	<p>output of the Y + SYNC signal, connected to the delay line via a resistor</p>
23	OSC	<p style="text-align: right;">MKA456</p>	<p>subcarrier-crystal in series with a trimmer, or an external subcarrier signal, via 1 nF in series with a resistor</p>
24	CS	<p style="text-align: right;">MKA457</p>	<p>composite SYNC signal input amplitude < 600 mV (p-p)</p>

PAL/NTSC encoder

TDA8501

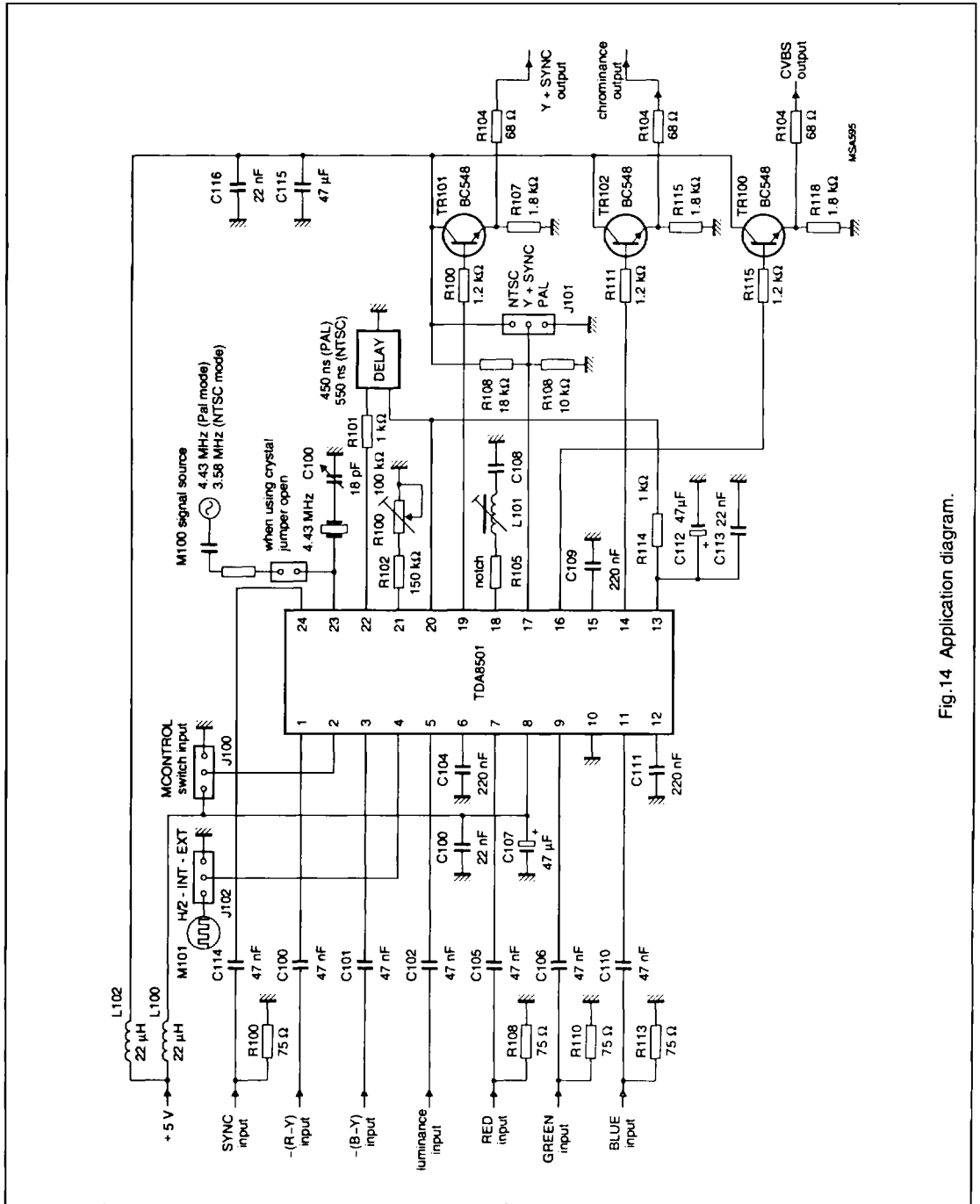

Fig. 14 Application diagram.