

Agilent HSMx-A4xx-xxxxx SMT LED

Surface Mount LED Indicator

Data Sheet

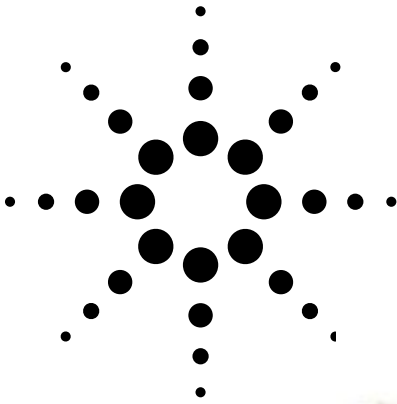

Description

Agilent Power PLCC-4 is an extension of our PLCC-2 SMT LEDs. The package can be driven at higher current due to its superior package design. The product is able to dissipate heat more efficiently compared to the conventional PLCC-2 SMT LEDs. In proportion to the increase in driving current, this family of LEDs is able to produce higher light output compared to the conventional PLCC-2 SMT LEDs.

These SMT LEDs have higher reliability and better performance and are designed to work under a wide range of environmental conditions. This higher reliability makes them suitable for use under harsh environment and conditions like automotive. In addition, they are also suitable to be used in electronic signs and signals.

To facilitate easy pick and place assembly, the LEDs are packed in EIA-compliant tape and reel. Every reel will be shipped in single intensity and color bin (except for red color), to provide close uniformity.

These LEDs are compatible with IR solder reflow process. Due to the high reliability feature of these products, they also can be mounted using through-the-wave soldering process.

There are a variety of colors and various viewing angles (30°, 60° and 120°) available in these SMT LEDs. Ideally, the 30° parts are suitable for light piping where focused intensities are required. As for the 60° and 120°, they are most suitable for automotive interior and exterior lighting and electronic signs applications.

Features

- Industry standard PLCC-4
- High reliability LED package
- High brightness using AlInGaP and InGaN dice technologies
- High optical efficiency
- Higher ambient temperature at the same current possible compared to TLED
- Available in full selection of colors
- Super wide viewing angle at 120°
- Available in 8mm carrier tape on 7-inch reel
- Compatible with both IR and TTW soldering process

Applications

- Interior automotive
 - Instrument panel backlighting
 - Central console backlighting
 - Cabin backlighting
 - Navigation and audio system
 - Dome lighting
 - Push button backlighting
- Exterior automotive
 - Turn signals
 - CHMSL
 - Rear combination lamp
 - Puddle light
- Electronic signs and signals
 - Interior and exterior full color sign
 - Variable message sign
 - Garden lighting
- Office automation, home appliances, industrial equipment
 - Front panel backlighting
 - Push button backlighting
 - Display backlighting

CAUTION: HSMN-, HSMK-, HSM-A40x-xxxxx LEDs are Class 2 ESD sensitive. Please observe appropriate precautions during handling and processing. Refer to Agilent Application Note AN-1142 for additional details.



Package Dimensions

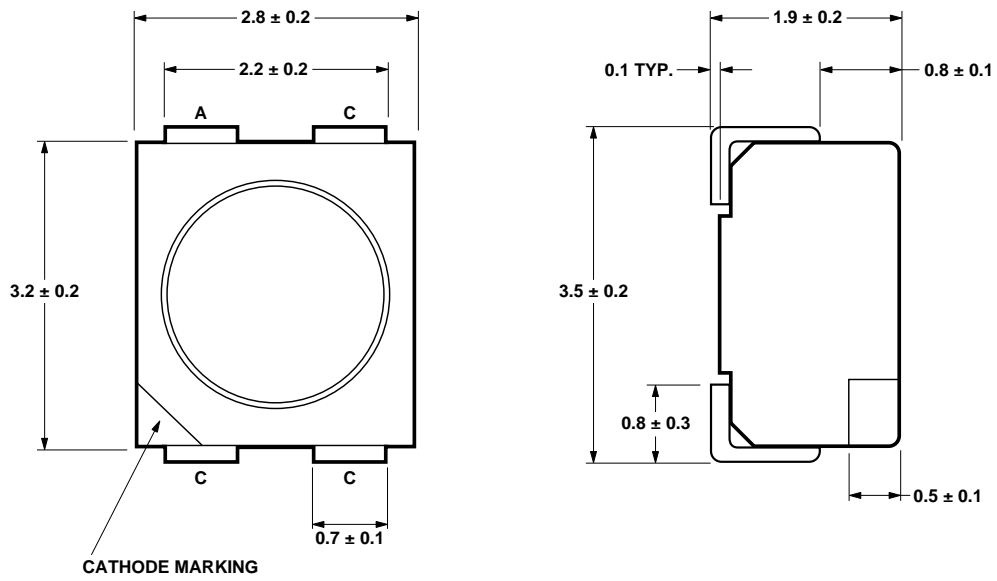

NOTE: ALL DIMENSIONS IN mm.

Device Selection Guide

Color	Part Number	Dice Technology	Luminous Intensity I_v (mcd) @ $I_F = 50$ mA	
			Min.	Typ.
Red	HSMC-A400-R00J1 ^[3]	AS AlInGaP	100	200
Red	HSMC-A401-T00J1 ^[3]	AS AlInGaP	250	400
Red Orange	HSMJ-A401-T00J1 ^[3]	AS AlInGaP	250	500
Orange	HSML-A401-U00J1 ^[3]	AS AlInGaP	400	700
Amber	HSMA-A400-R00J1 ^[3]	AS AlInGaP	100	150
Amber	HSMA-A401-U00J1 ^[3]	AS AlInGaP	400	550
Yellow Green	HSME-A400-P02J1	AS AlInGaP	40	100
Yellow Green	HSME-A401-Q02J1	AS AlInGaP	63	100
Emerald Green	HSME-A400-P01J1	AS AlInGaP	40	70

Color	Part Number	Dice Technology	Luminous Intensity I_v (mcd) @ $I_F = 30$ mA	
			Min.	Typ.
Green	HSMM-A401-R00J1	InGaN	100	280
Cyan	HSMK-A401-R00J1	InGaN	100	180
Blue	HSMN-A401-N00J1	InGaN	25	80

Notes:

1. The luminous intensity I_v is measured at the mechanical axis of the lamp package. The actual peak of the spatial radiation pattern may not be aligned with this axis.
2. $\theta_{1/2}$ is the off-axis angle where the luminous intensity is 1/2 the peak intensity.
3. Designed for Automotive Application.

Absolute Maximum Ratings ($T_A = 25^\circ\text{C}$)

Parameters	AS AlInGaP	InGaN
DC Forward Current ^[1]	70 mA ^[3,4]	30 mA
Peak Forward Current ^[2]	200 mA	90 mA
Power Dissipation	180 mW	114 mW
Reverse Voltage	5 V	5 V
Junction Temperature	110°C	110°C
Operating Temperature	-40°C to +100°C	-40°C to +100°C
Storage Temperature	-40°C to +100°C	-40°C to +100°C

Notes:

1. Derate linearly as shown in figure 5.
2. Duty factor = 10%, Frequency = 1 kHz.
3. Drive current between 10 mA and 70 mA is recommended for best long-term performance.
4. Operation at current below 5 mA is not recommended.

Optical Characteristic (T_A = 25°C)

Color	Dice Technology	Peak Wavelength λ_{PEAK} (nm) Typ.	Dominant Wavelength λ_D (nm) Typ.	Viewing Angle $2\theta_{1/2}$ (Degrees) Typ.	Luminous Efficacy $\eta_v^{[5]}$ (lm/W) Typ.	Luminous Intensity/ Total Flux I_v (mcd)/ Φ_v (mIm) Typ.
Red	AS AlInGaP	635	626	120	150	0.45
Red Orange	AS AlInGaP	621	615	120	240	0.45
Orange	AS AlInGaP	609	605	120	320	0.45
Amber	AS AlInGaP	592	590	120	480	0.45
Yellow Green	AS AlInGaP	576	575	120	560	0.45
Emerald Green	AS AlInGaP	568	567	120	610	0.45
Green	InGaN	518	525	120	500	0.45
Cyan	InGaN	502	505	120	300	0.45
Blue	InGaN	468	472	120	75	0.45

Notes:

1. The dominant wavelength, λ_D , is derived from the CIE Chromaticity Diagram and represents the color of the device.
2. $\theta_{1/2}$ is the off-axis angle where the luminous intensity is 1/2 the peak intensity.
3. Radiant intensity, I_e in watts/steradian, may be calculated from the equation $I_e = I_v/\eta_v$, where I_v is the luminous intensity in candelas and η_v is the luminous efficacy in lumens/watt.

Electrical Characteristic (T_A = 25°C)

Dice Technology	Forward Voltage V_F (Volts) @ $I_F = 50$ mA		Reverse Voltage V_R @ 100 μ A
	Typ.	Max.	Min.
AS AlInGaP	2.2	2.5	5

Dice Technology	Forward Voltage V_F (Volts) @ $I_F = 30$ mA		Reverse Voltage V_R @ 10 μ A
	Typ.	Max.	Min.
InGaN	3.8	4.6	5

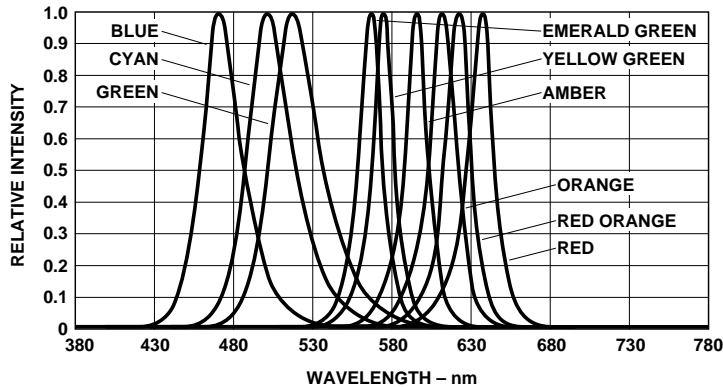

Figure 1. Relative intensity vs. wavelength.

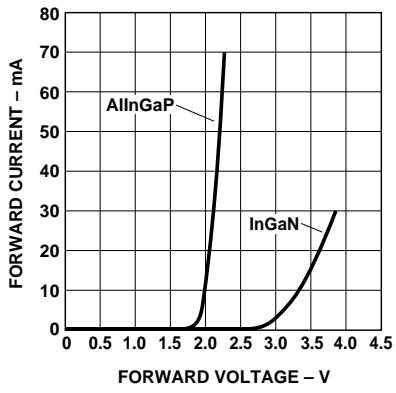

Figure 2. Forward current vs. forward voltage.

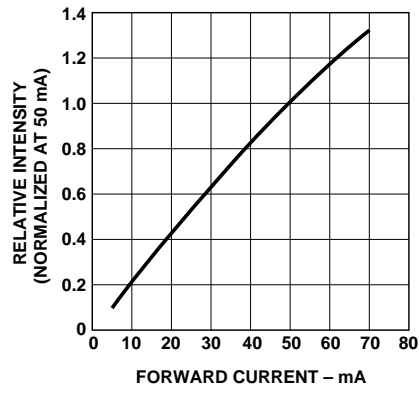

Figure 3. Relative intensity vs. forward current (AllInGaP).

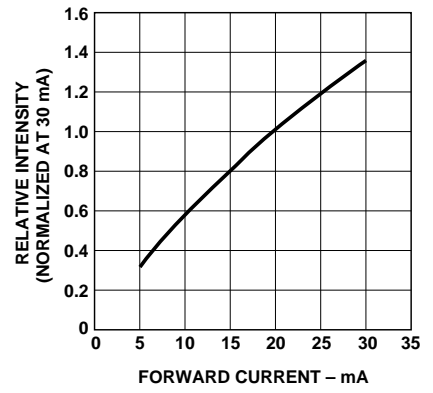

Figure 4. Relative intensity vs. forward current (InGaN).

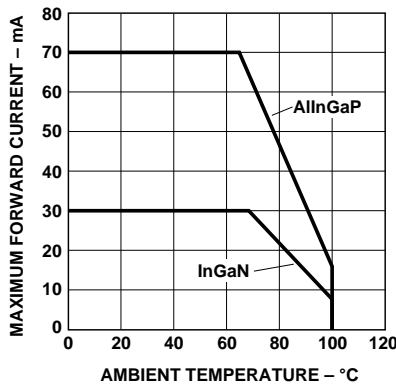

Figure 5. Maximum forward current vs. ambient temperature, derated based on $T_{jmax} = 110^{\circ}C$, $R_{\theta JA} = 300^{\circ}C/W$.

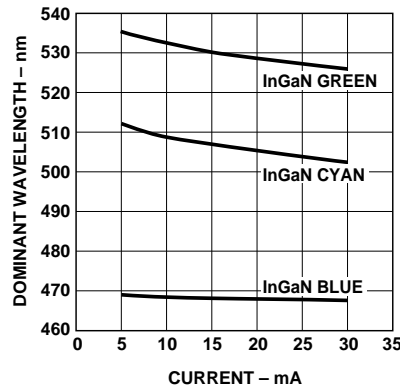

Figure 6. Dominant wavelength vs. forward current – InGaN devices.

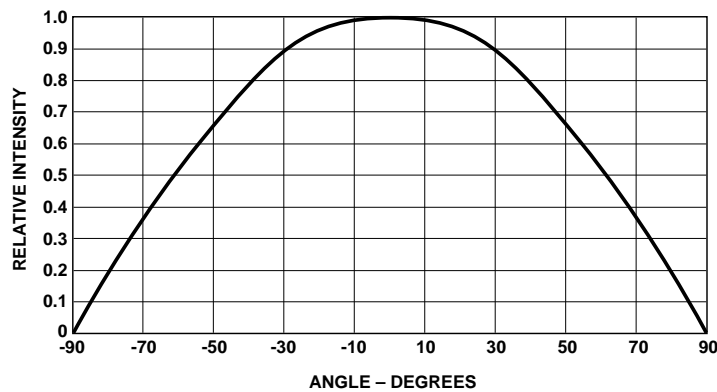
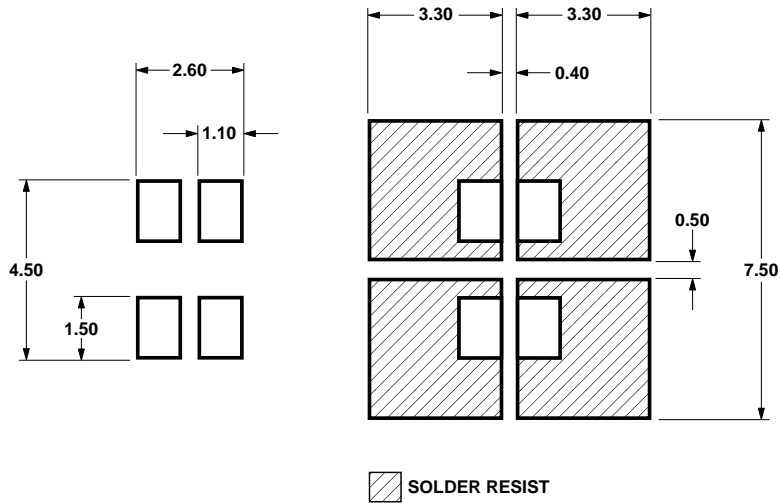

Figure 7. Radiation pattern.



DIMENSIONS IN mm.

Figure 8a. Recommended soldering pad pattern.

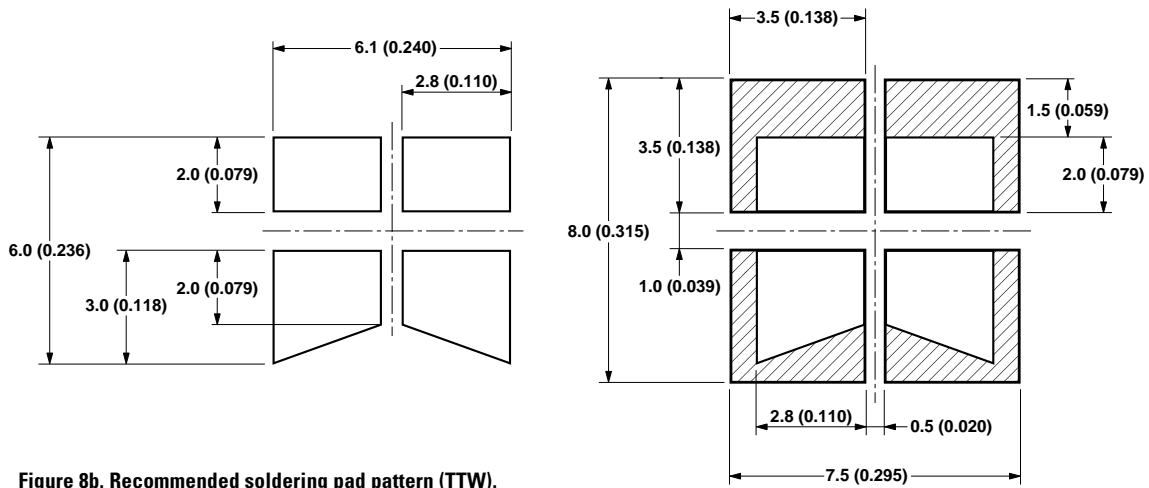

Figure 8b. Recommended soldering pad pattern (TTW).

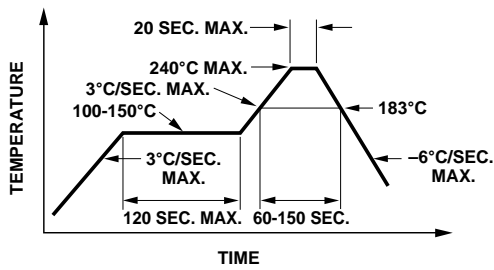

Figure 9. Recommended reflow soldering profile.

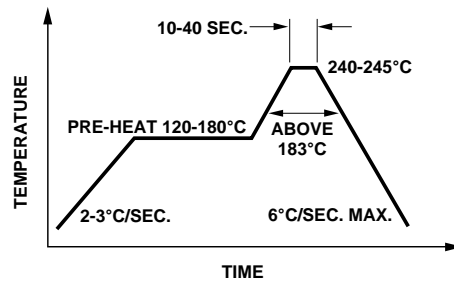

Figure 10. Recommended wave soldering profile.

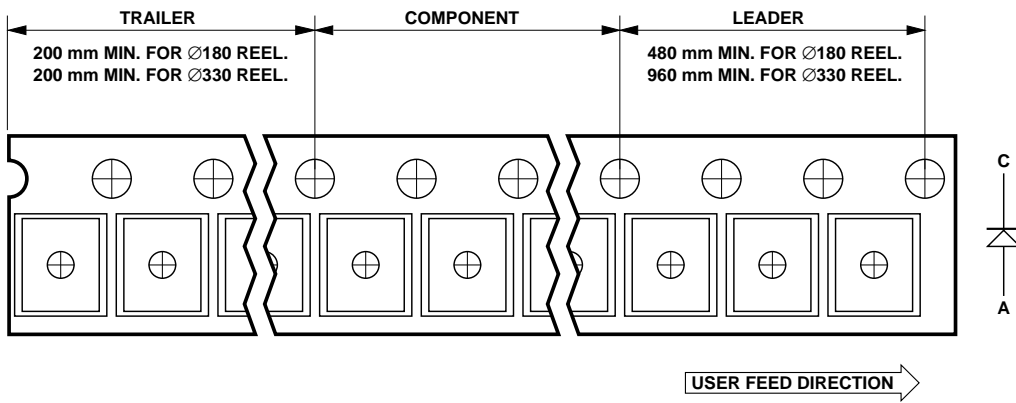

Figure 11. Tape leader and trailer dimensions.

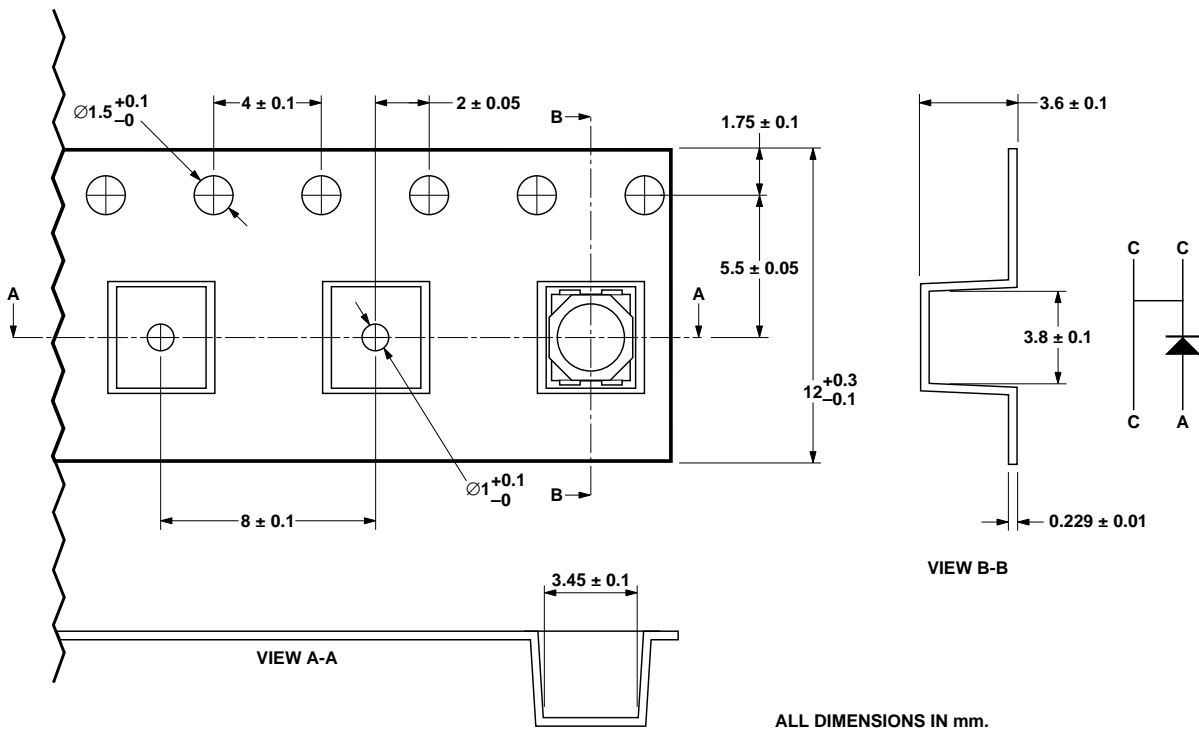

Figure 12. Tape dimensions.

ALL DIMENSIONS IN mm.

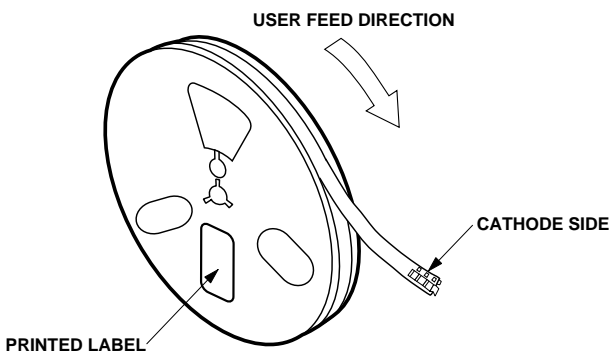

Figure 13. Reeling orientation.

Storage Condition: 5 to 30°C @ 60% relative humidity max.

Baking is required under the condition:

- a) the humidity indicator card color becoming pink
- b) the pack has been opened for more than 1 week

Baking recommended condition: 60 ± 5°C for 20 hours.

Intensity Bin Select (X5X6)

Individual reel will contain parts from one half bin only.

X5	Min. lv Bin
X6	
0	Full Distribution
3	3 half bins starting from X51
4	4 half bins starting from X51
5	5 half bins starting from X51
7	3 half bins starting from X52
8	4 half bins starting from X52
9	5 half bins starting from X52

Intensity Bin Limits

Bin ID	Min. (mcd)	Max. (mcd)
N1	28.50	35.50
N2	35.50	45.00
P1	45.00	56.00
P2	56.00	71.50
Q1	71.50	90.00
Q2	90.00	112.50
R1	112.50	140.00
R2	140.00	180.00
S1	180.00	224.00
S2	224.00	285.00
T1	285.00	355.00
T2	355.00	450.00
U1	450.00	560.00
U2	560.00	715.00
V1	715.00	900.00
V2	900.00	1125.00
W1	1125.00	1400.00
W2	1400.00	1800.00

Tolerance of each bin limit = $\pm 12\%$

Color Bin Select (X7)

Individual reel will contain parts from one full bin only.

X7	
0	Full Distribution
Z	A and B only
Y	B and C only
W	C and D only
V	D and E only
U	E and F only
T	F and G only
S	G and H only
Q	A, B and C only
P	B, C and D only
N	C, D and E only
M	D, E and F only
L	E, F and G only
K	F, G and H only
1	A, B, C and D only
2	E, F G and H only

Color Bin Limits

Blue	Min. (nm)	Max. (nm)
A	460.0	465.0
B	465.0	470.0
C	470.0	475.0
D	475.0	480.0

Cyan	Min. (nm)	Max. (nm)
A	490.0	495.0
B	495.0	500.0
C	500.0	505.0
D	505.0	510.0

Green	Min. (nm)	Max. (nm)
A	515.0	520.0
B	520.0	525.0
C	525.0	530.0
D	530.0	535.0

Color Bin Limits

Emerald		
Green	Min. (nm)	Max. (nm)
A	552.5	555.5
B	555.5	558.5
C	558.5	561.5
D	561.5	564.5

Yellow		
Green	Min. (nm)	Max. (nm)
E	564.5	567.5
F	567.5	570.5
G	570.5	573.5
H	573.5	576.5

Amber/ Yellow		
Min. (nm)	Max. (nm)	
A	582.0	584.5
B	584.5	587.0
C	587.0	589.5
D	589.5	592.0
E	592.0	594.5
F	594.5	597.0

Orange	Min. (nm)	Max. (nm)
A	597.0	600.0
B	600.0	603.0
C	603.0	606.0
D	606.0	609.0
E	609.0	612.0

Red		
Orange	Min. (nm)	Max. (nm)
A	611.0	616.0
B	616.0	620.0

Red	Min. (nm)	Max. (nm)
-----	-----------	-----------

Full Distribution

Tolerance of each bin limit = ± 1 nm

Packaging Option (X8X9)

X8X9	
J1	Top Mount, 7 inch Reel

www.agilent.com/semiconductors

For product information and a complete list of distributors, please go to our web site.

For technical assistance call:

Americas/Canada: +1 (800) 235-0312 or
(408) 654-8675

Europe: +49 (0) 6441 92460

China: 10800 650 0017

Hong Kong: (+65) 6271 2451

India, Australia, New Zealand: (+65) 6271 2394

Japan: (+81 3) 3335-8152(Domestic/International), or 0120-61-1280(Domestic Only)

Korea: (+65) 6271 2194

Malaysia, Singapore: (+65) 6271 2054

Taiwan: (+65) 6271 2654

Data subject to change.

Copyright © 2003 Agilent Technologies, Inc.

March 4, 2003

5988-8320EN



Agilent Technologies