

Resistor/Capacitor Networks, Molded SIP



FEATURES

- Custom schematics available
- NP0 or X7R capacitors for line terminator
- Wide operating temperature range (- 55 °C to 125 °C)
- Molded epoxy case
- Solder coated copper terminals
- Solderability per MIL-STD-202 method 208E
- Marking resistance to solvents per MIL-STD-202 method 215

STANDARD ELECTRICAL SPECIFICATIONS

MODEL	SCHEMATIC	RESISTOR CHARACTERISTICS				CAPACITOR CHARACTERISTICS			
		POWER RATING P _{70 °C} W	RESISTANCE (Ω)	RESISTANCE TOLERANCE ± %	TEMP. COEFF. ± ppm/°C	TYPE (2)	CAPACITANCE RANGE	CAPACITANCE TOLERANCE (3) ± %	CAPACITANCE VOLTAGE VDC
MRCN	10	0.20	50 - 1K	2 %, 5 % (1 %) ⁽¹⁾	150 ppm	NP0	33 pF - 3900 pF	10 %, 20 %	50
						X7R	470 pF - 0.1 μF	10 %, 20 %	
	20	0.20	50 - 1K	2 %, 5 % (1 %) ⁽¹⁾	150 ppm	NP0	33 pF - 3900 pF	10 %, 20 %	50
						X7R	470 pF - 0.1 μF	10 %, 20 %	
	30	0.20	50 - 1K	2 %, 5 % (1 %) ⁽¹⁾	150 ppm	NP0	33 pF - 3900 pF	10 %, 20 %	50
						X7R	470 pF - 0.1 μF	10 %, 20 %	

Notes

- (1) ± 1 % tolerance available on request
 (2) NP0 Capacitors may be substituted for X7R capacitors
 (3) Tighter tolerances available on request

SCHEMATICS

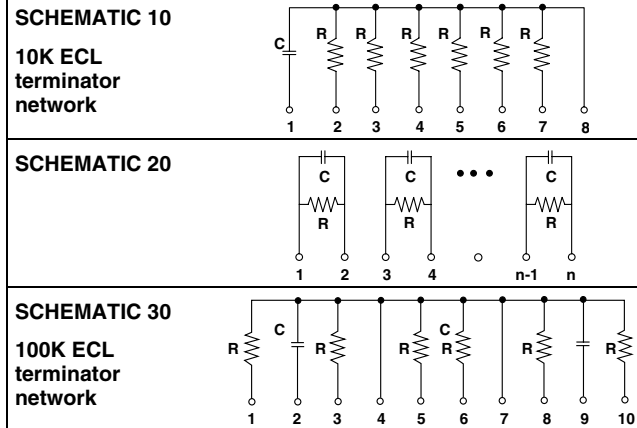

Note

- Custom schematics available

DIMENSIONS in inches [millimeters]

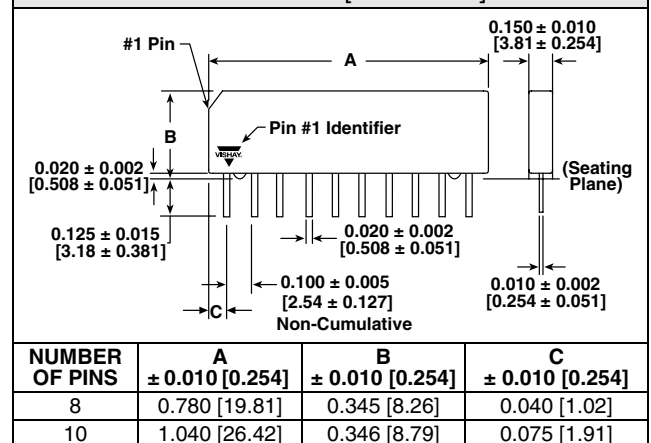

GLOBAL PART NUMBER INFORMATION

New Global Part Numbering: MRCN081N101J560KT B (preferred part number format)

M	R	C	N	0	8	1	N	1	0	1	J	5	6	0	K	T	B
GLOBAL MODEL	PIN COUNT	SCHEMATIC	CHARACTERISTIC	RESISTANCE VALUE	RESISTANCE TOLERANCE	CAPACITANCE VALUE	CAPACITANCE TOLERANCE	TERMINAL FINISH	PACKAGING								
MRCN	08 = 8 pin 10 = 10 pin	1 = 10 2 = 20 3 = 30	N = NP0 X = X7R	2 digit significant figure, followed by a multiplier 101 = 100 Ω 220 = 22 Ω 102 = 1 kΩ	F = 1 % G = 2 % J = 5 %	(in picofarads) 2 digit significant figure, followed by a multiplier 101 = 100 pF 392 = 3000 pF 104 = 0.1 μF	K = 10 % M = 20 %	T = Sn90/Pb10	B = Bulk T = Tray								

Historical Part Numbering: MRCN0801101J560KS10 (will continue to be accepted)

MRCN	08	01	101	J	560	K	S10
HISTORICAL MODEL	PIN COUNT	SCHEMATIC	RESISTANCE VALUE	RESISTANCE TOLERANCE	CAPACITANCE VALUE	CAPACITANCE TOLERANCE	TERMINAL FINISH



Disclaimer

All product specifications and data are subject to change without notice.

Vishay Intertechnology, Inc., its affiliates, agents, and employees, and all persons acting on its or their behalf (collectively, "Vishay"), disclaim any and all liability for any errors, inaccuracies or incompleteness contained herein or in any other disclosure relating to any product.

Vishay disclaims any and all liability arising out of the use or application of any product described herein or of any information provided herein to the maximum extent permitted by law. The product specifications do not expand or otherwise modify Vishay's terms and conditions of purchase, including but not limited to the warranty expressed therein, which apply to these products.

No license, express or implied, by estoppel or otherwise, to any intellectual property rights is granted by this document or by any conduct of Vishay.

The products shown herein are not designed for use in medical, life-saving, or life-sustaining applications unless otherwise expressly indicated. Customers using or selling Vishay products not expressly indicated for use in such applications do so entirely at their own risk and agree to fully indemnify Vishay for any damages arising or resulting from such use or sale. Please contact authorized Vishay personnel to obtain written terms and conditions regarding products designed for such applications.

Product names and markings noted herein may be trademarks of their respective owners.