

711 Series Single/Multi Way Bayonet Coupled Connectors

DB2

Data Bus Interconnection System

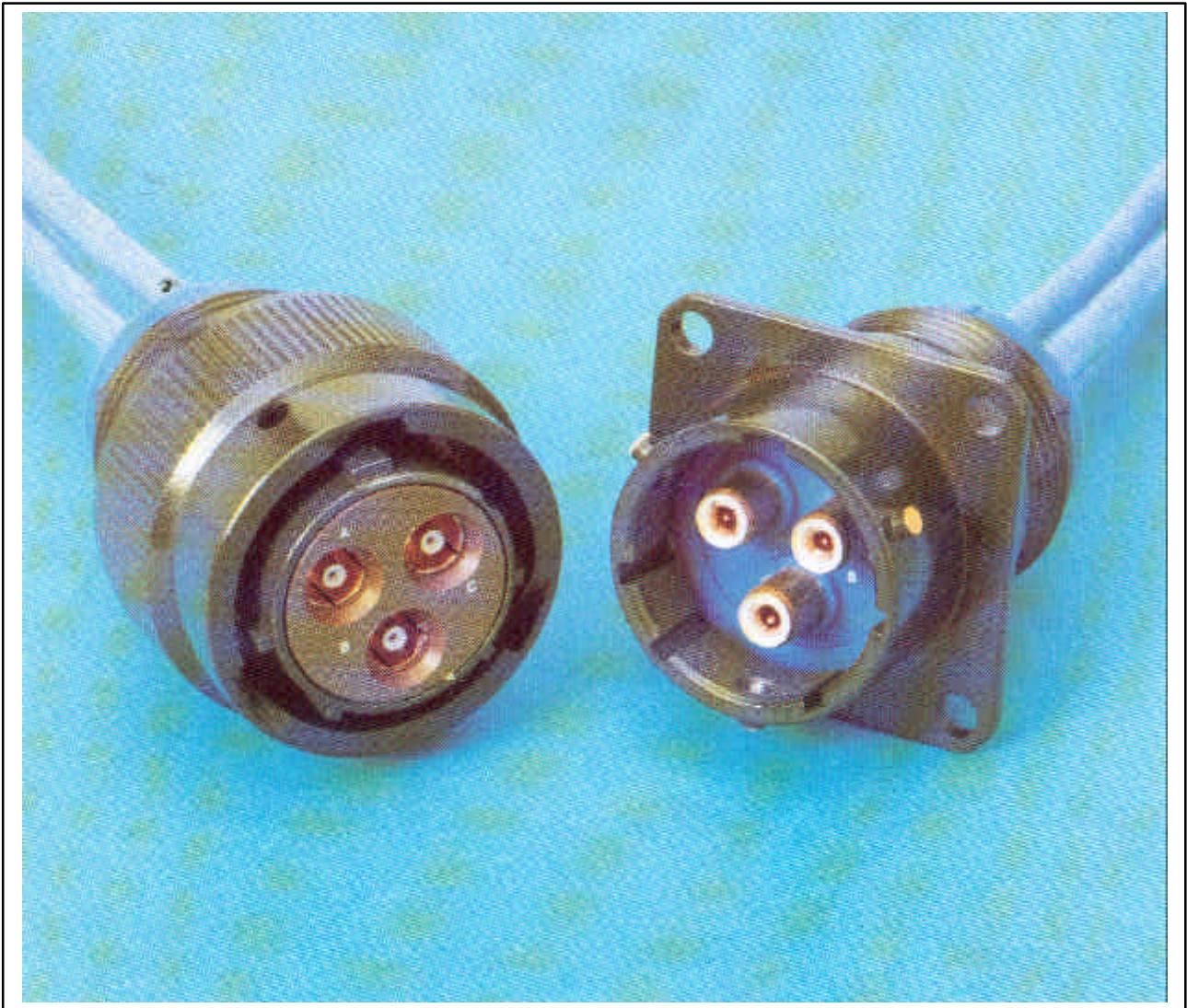

This high density Data Bus Interconnection System has been designed specifically for use with data transmission as defined MIL-STD-15538, STANAG 3838 and DEF STAN 00-18 (Part 2).

Approved to BS 9522 F0042 and qualified to PAN 6484/6499 this interconnection system is also ideal for use with video transmission systems and the termination of screened twisted pairs.

Amphenol

Single/Multi Way Bayonet Coupling Connectors

(All crimp contact. All contacts grounded to shell)

Single Way Plug (to accept EL 2112 Patt. 602 back end accessories) - 06E08-1 S

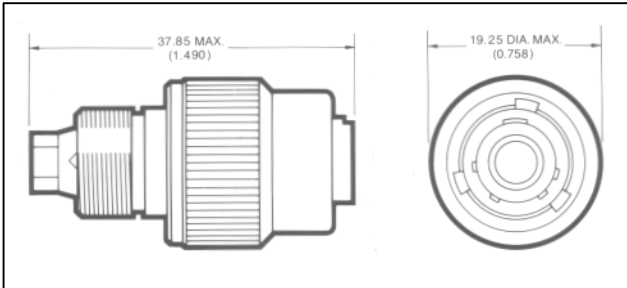

Single Way Plug 06E 08-1 S (510)

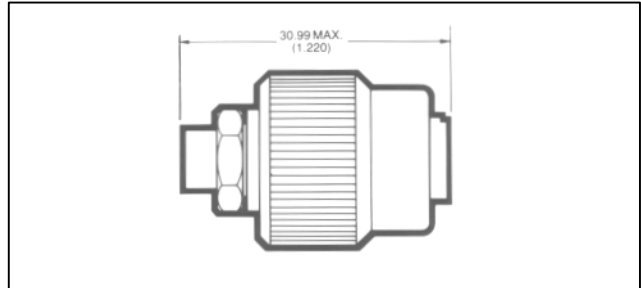

Multi Way Plug - 06E /C2811-/PAN 6486 F

Shell Size	C max. Dia.	G max.	H max.	L Thd UNEF 2A
14	30.05 (1.183)	7.50 (0.295)	31.24 (1.230)	7/8 - 20
16	33.15 (1.305)	7.50 (0.295)	31.24 (1.230)	1 - 20
18	35.33 (1.391)	7.50 (0.295)	31.24 (1.230)	1 1/16 - 18
20	38.89 (1.531)	7.50 (0.295)	31.24 (1.230)	1 3/16 - 18
22	42.06 (1.656)	7.50 (0.295)	31.24 (1.230)	1 5/16 - 18
24	45.14 (1.777)	7.50 (0.295)	31.24 (1.230)	1 7/16 - 18

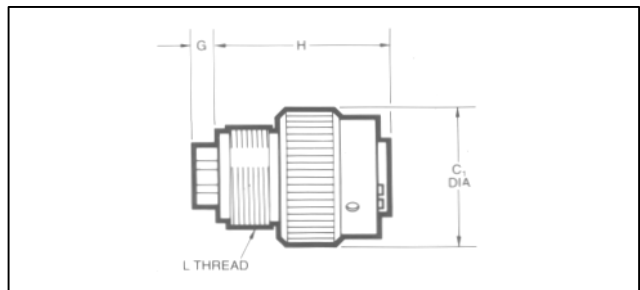

Single Way Plug with heavy duty Coupling Ring - 05E08-1 S (To accept EL 2112 Patt. 602 back end accessories)

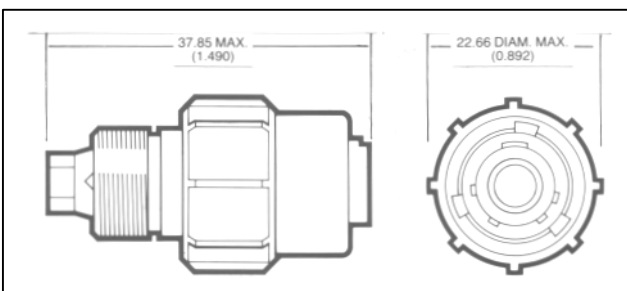

Single way plug with heavy duty coupling ring 05E08-1 S(510)

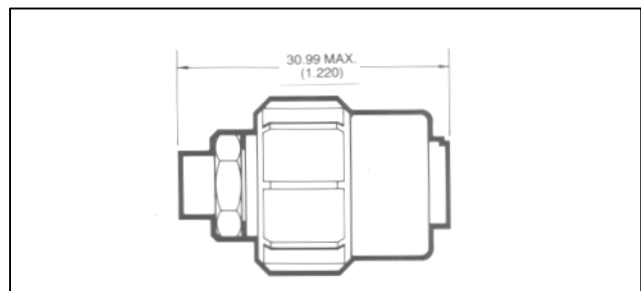

Multi Way Plug with heavy duty Coupling Ring - 05E /C2812

Shell Size	C ₂ Max. Dia.	G max.	H max.	L Thd UNEF 2A
14	31.18 (1.267)	7.50 (0.295)	31.24 (1.230)	7/8 - 20
16	36.93 (1.454)	7.50 (0.295)	31.24 (1.230)	1 - 20
18	39.70 (1.563)	7.50 (0.295)	31.24 (1.230)	1 1/16 - 18
20	42.85 (1.687)	7.50 (0.295)	31.24 (1.230)	1 3/16 - 18
22	45.64 (1.797)	7.50 (0.295)	31.24 (1.230)	1 5/16 - 18
24	48.82 (1.922)	7.50 (0.295)	31.24 (1.230)	1 7/16 - 18

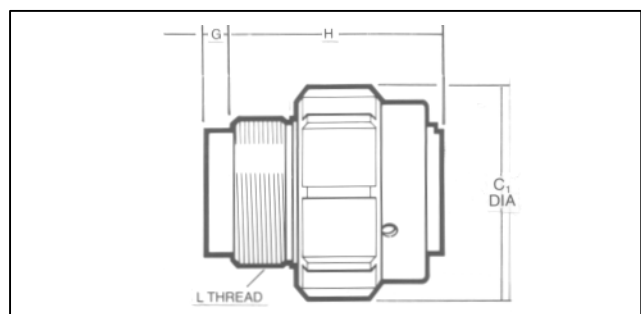

Single Way Single Hole Mtg. Receptacle - 07E08-1 P

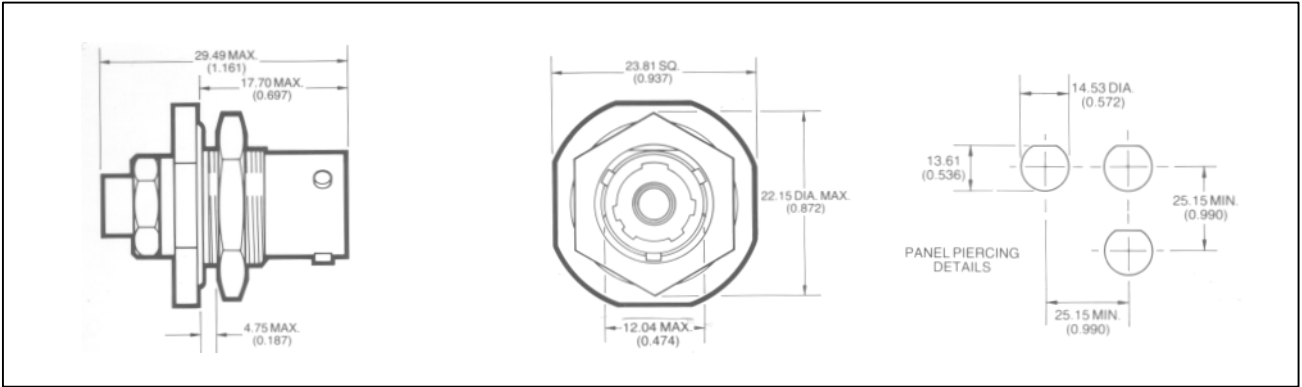

Multi Way Single Hole Mtg. Receptacle - 07E /C2814-/PAN 6486A

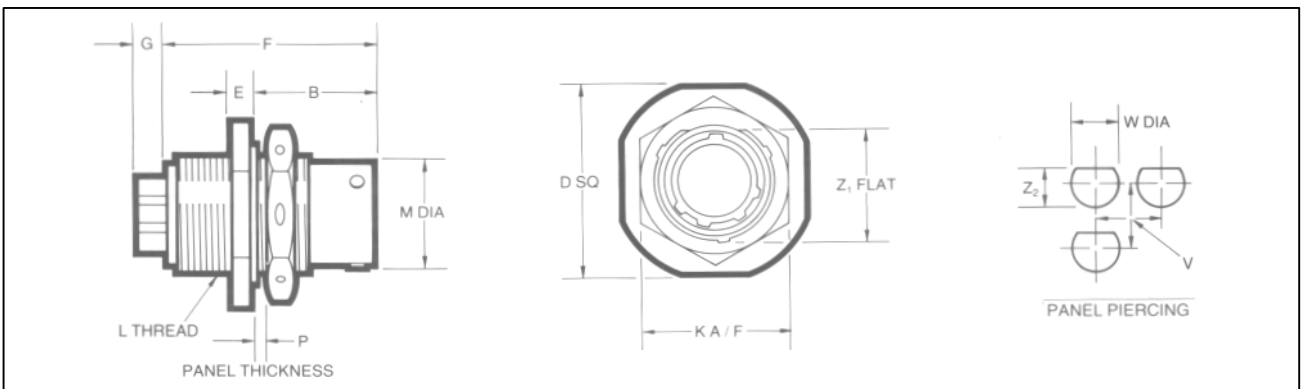

Shell Size	B Max.	D SQ	E max.	F max.	G max.	KA/F max.	L Thd UNEF 2A	M max. dia.	P Panel thickness		v min.	W dia ± 0.13 (± .005)	Z ₁ ± 0.13 (± .005)	Z ± 0.13 (± .005)
14	17.96 (0.707)	35.33 (1.391)	2.87 (0.113)	30.86 (1.215)	7.50 (0.295)	30.61 (1.205)	$\frac{7}{8} - 20$	22.25 (0.876)	4.75 (0.187)	1.57 (0.062)	36.32 (1.430)	25.65 (1.010)	23.80 (0.937)	24.08 (0.948)
16	17.96 (0.707)	38.51 (1.516)	2.87 (0.113)	30.86 (1.215)	7.50 (0.295)	33.76 (1.329)	1 - 20	25.43 (1.001)	4.75 (0.187)	1.57 (0.062)	39.88 (1.570)	28.83 (1.135)	26.95 (1.061)	27.23 (1.072)
18	17.96 (0.707)	41.68 (1.641)	2.87 (0.113)	30.86 (1.215)	7.50 (0.295)	36.96 (1.455)	1 $\frac{1}{16}$ - 18	28.60 (1.126)	4.75 (0.187)	1.57 (0.062)	43.69 (1.720)	32.00 (1.260)	30.12 (1.186)	30.40 (1.197)
20	19.61 (0.772)	46.43 (1.828)	3.76 (0.148)	32.38 (1.275)	7.50 (0.295)	40.11 (1.579)	1 $\frac{3}{16}$ - 18	31.78 (1.251)	6.35 (0.250)	1.57 (0.062)	47.37 (1.865)	35.18 (1.385)	33.30 (1.311)	33.58 (1.322)
22	19.61 (0.772)	49.63 (1.954)	3.76 (0.148)	32.38 (1.275)	7.50 (0.295)	43.31 (1.705)	1 $\frac{5}{16}$ - 18	34.95 (1.376)	6.35 (0.250)	1.57 (0.062)	50.93 (2.005)	38.35 (1.510)	36.47 (1.436)	36.75 (1.447)
24	19.61 (0.772)	52.78 (2.078)	3.76 (0.148)	32.38 (1.275)	7.50 (0.295)	46.46 (1.829)	1 $\frac{7}{16}$ - 18	38.13 (1.501)	5.56 (0.219)	1.57 (0.062)	54.61 (2.150)	41.53 (1.635)	39.65 (1.561)	39.93 (1.572)

Single Way Flange Mtg. Receptacle - OOE08-1 P

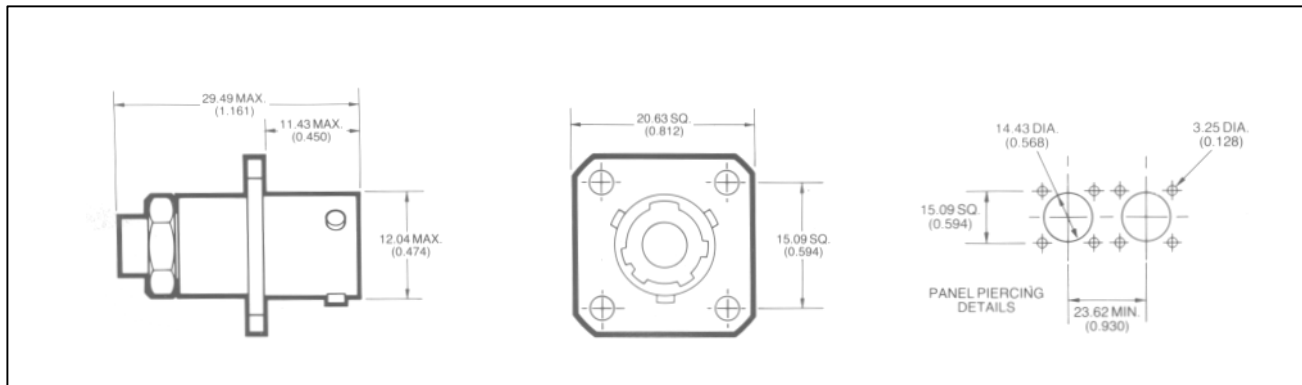

Multi Way Flange Mtg. Receptacle - OOE /C2813-/PAN 6486B-

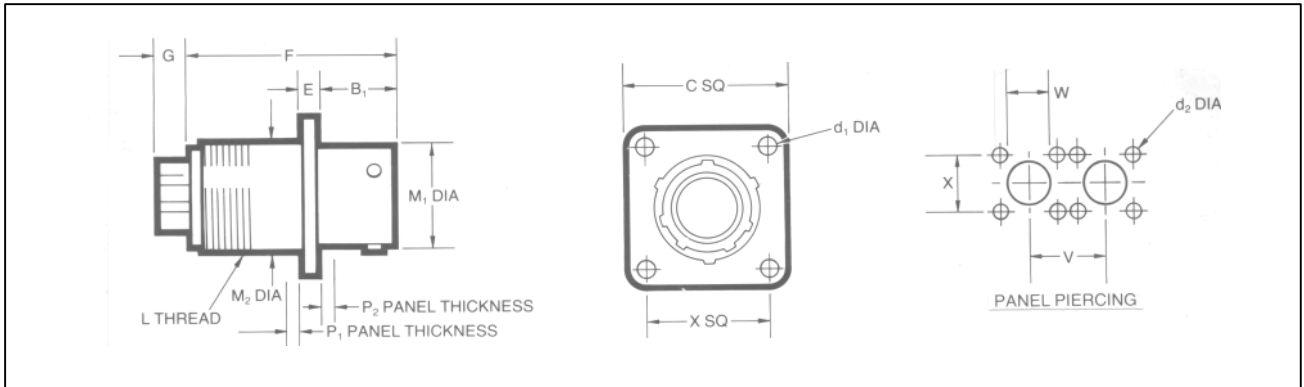

Shell Size	B ± 0.38 (± .015)	C sq. max.	d, dia ± 0.05 (± .002)	d ₂ dia ± 0.13 (± .005)	E ± 0.41 (± .016)	F max.	G max.	L Thd UNEQ 2A	M ₁ Dia. max.	M ₂ Dia. max.	P ₁ max.	P ₂ max.	V min.	W dia ± 0.13 (± .005)	x sq ± 0.13 (± .005)
14	11.33 (0.446)	28.98 (1.141)	3.18 (0.125)	3.25 (0.128)	1.57 (0.062)	30.86 (1.215)	7.50 (0.295)	7/8 - 20	22.25 (0.876)	22.22 (0.875)	3.18 (0.125)	2.21 (0.087)	33.15 (1.305)	25.12 (0.989)	23.01 (0.906)
	16	11.33 (0.446)	31.34 (1.234)	3.18 (0.125)	3.25 (0.128)	1.57 (0.062)	30.86 (1.215)		7.50 (0.295)	1 - 20	25.43 (1.001)	25.40 (1.000)	3.18 (0.125)	2.21 (0.087)	37.85 (1.490)
18	11.33 (0.446)	33.73 (1.328)	3.18 (0.125)	3.25 (0.128)	1.57 (0.062)	30.86 (1.215)	7.50 (0.295)	1 1/16 - 18	28.60 (1.126)		26.97 (1.062)	3.18 (0.125)	2.21 (0.087)	40.64 (1.600)	31.45 (1.238)
	20	14.50 (0.571)	36.91 (1.453)	3.18 (0.125)	3.25 (0.128)	2.39 (0.094)	32.38 (1.275)		7.50 (0.295)	1 3/16 - 18	31.78 (1.251)	30.15 (1.187)	3.18 (0.125)	5.38 (0.212)	43.81 (1.725)
22	14.50 (0.571)	40.08 (1.578)	3.18 (0.125)	3.25 (0.128)	2.39 (0.094)	32.38 (1.275)	7.50 (0.295)	1 5/16 - 18	34.95 (1.376)		33.32 (1.312)	3.18 (0.125)	5.38 (0.212)	46.61 (1.835)	37.80 (1.488)
	24	15.37 (0.605)	43.26 (1.703)	3.86 (0.152)	3.94 (0.155)	2.39 (0.094)	32.38 (1.275)		7.50 (0.295)	1 7/16 - 18	38.13 (1.501)	36.50 (1.437)	3.18 (0.125)	5.38 (0.212)	49.78 (1.960)

Multi Way Flange Mtg. Receptacle with P.C. Termination Contacts - 02A (219) Deviation /C2815-

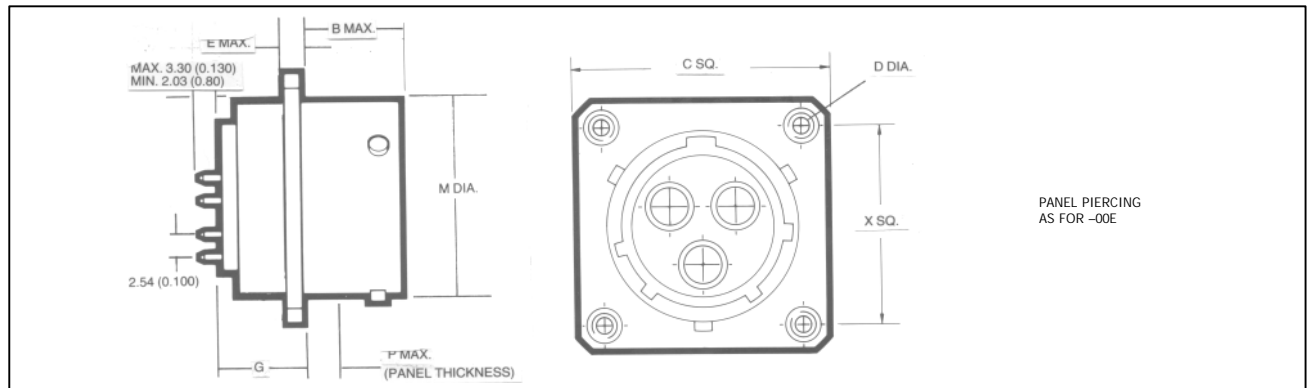

Shell Size	B max.	C Sq. max.	D Dia. ±0.05 (±0.002)	E max.	G max.	M Dia. max.	P max.
14	11.71 (0.461)	28.98 (1.141)	3.18 (0.125)	1.96 (0.077)	9.37 (0.369)	22.25 (0.876)	2.21 (0.087)
16	11.71 (0.461)	31.34 (1.234)	3.18 (0.125)	1.96 (0.077)	9.37 (0.369)	25.43 (1.001)	2.21 (0.087)
18	11.71 (0.461)	33.73 (1.328)	3.18 (0.125)	1.96 (0.077)	9.37 (0.369)	28.60 (1.126)	2.21 (0.087)

Single Way Plug Terminator 77± 1%-06ET08-1S (77)

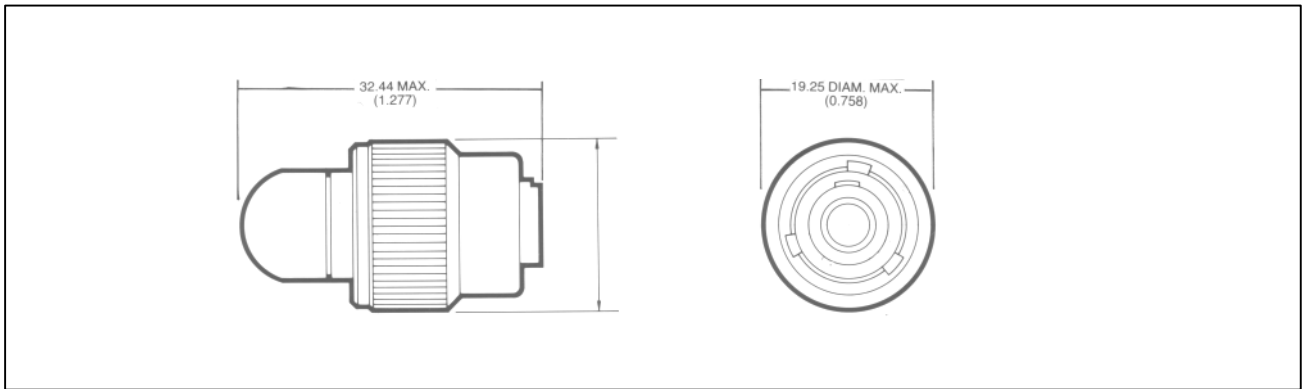

Multi Way Insert Availability

Lettering of inserts shown here corresponds to views of front (mating) surface of pin inserts.

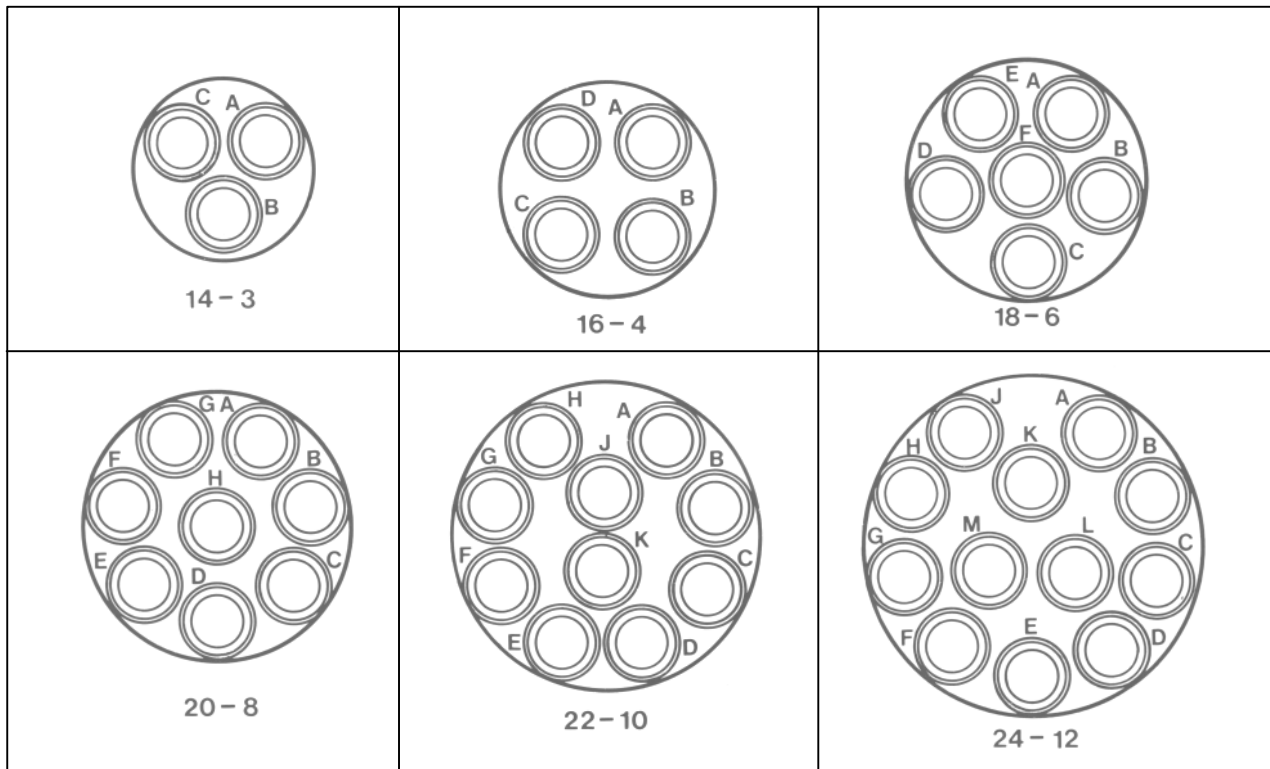

Protective Caps and Backshells

This series of connectors is designed to use EL2112 Patt. 602 accessories.

Terminating Contacts (for use with multi way connectors)

Pin terminator $3K\Omega\pm 5\%$ - 711-0176-3K also $77\Omega\pm 1\%$

Socket terminator $3K\Omega\pm 5\%$ - 711-0125-3K also $77\Omega\pm 1\%$

Dummy Contact and Seal Plug Kit (for use with multi way connectors)

Pin 711-0174-P

Socket 711-0174-S

Contacts

Pin 711-0013-2 Socket 711-0014-3

Tools for 711 Series Connectors

Centre contact crimp-Crimp tool M22520/2-01.

Positioner 2946 B-5027-1.

Intermediate/Outer crimp - Crimp tool 227-944 (M22520/5-01).

Die Set 294GB-5026-1.

Insertion/Removal tool -294GB-5028.

Metal removal tool - 294GB-5047.

Single/Multi Way

Ordering by Amphenol Part Numbers

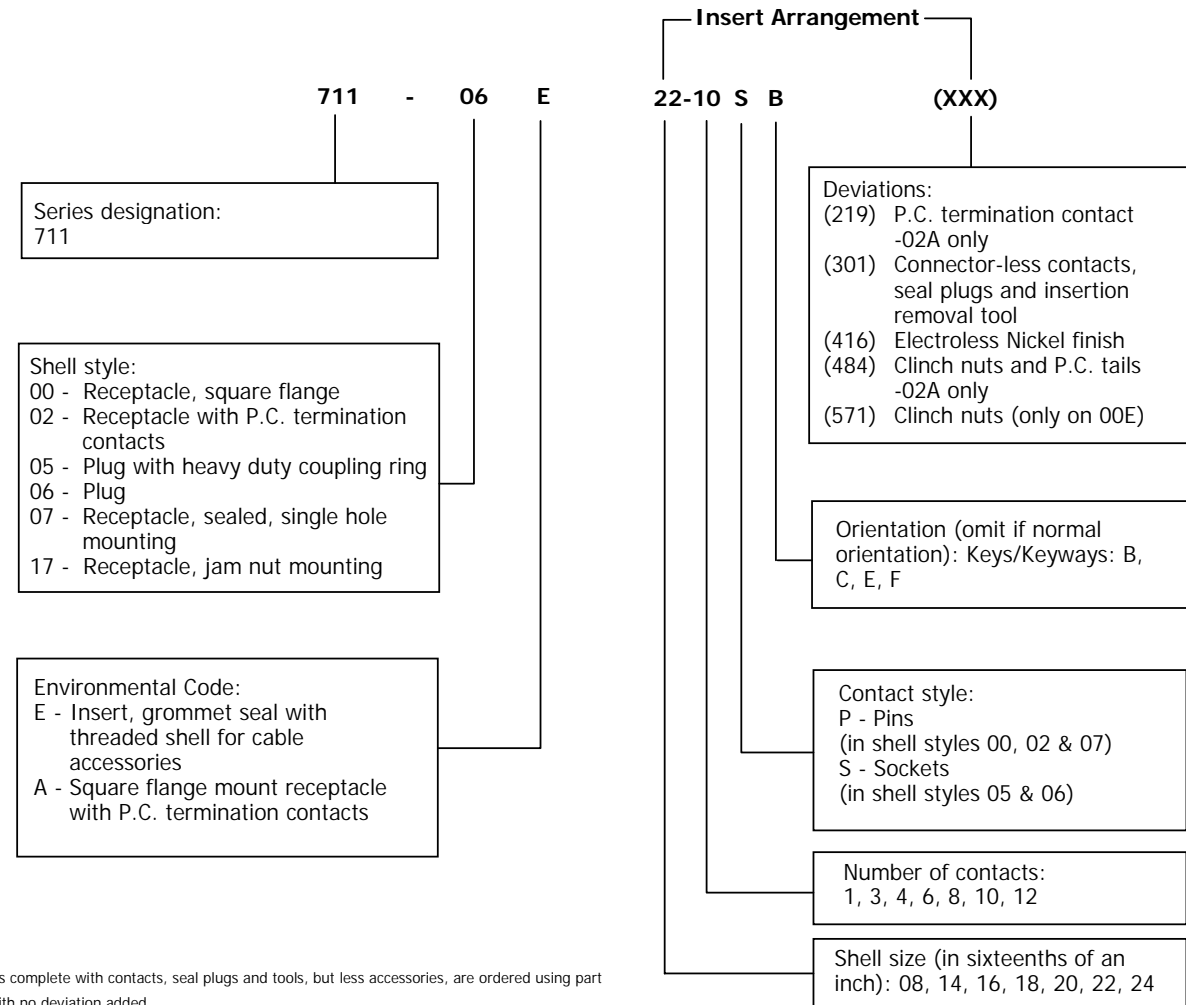

Connectors complete with contacts, seal plugs and tools, but less accessories, are ordered using part number with no deviation added.

Ordering by BS Part Number

BS 9522 F0042 C2811 14 03 F N 0

Basic Number

Shell Style	
C2811 as per shell style	06E-
C2812 as per shell style	05E-
C2813 as per shell style	00E-
C2814 as per shell style	07E-
C2815 as per shell style	02A-

Variant
 0 = CAD/Olive drab
 1 = Electroless nickel
 2 = Zinc Cobalt/Olive drab

Key polarisation
 N = Normal
 B,C,E,F available

Contact Type F = Socket contact M = Pin contact (All plugs have socket contacts) All receipts have Pin contacts)

Contact arrangement

Shell size

Ordering by Pan Part Number

PAN 6486 F 14 03 S N X

Basic number

Shell Style	
Pan 6486A as per shell style	07E
Pan 6486B	00E
Pan 6486E	06E

Deviation
 None = Inclusive of contacts, seal plugs and tools
 1 = Less contacts/Seal plugs and removal tools
 2 = Less contacts

Orientation
 N = Normal
 B,C,E,F available

Contact Type
 S = Socket
 P = Pin

Contact arrangements

Shell size

Key/Keyway Orientations

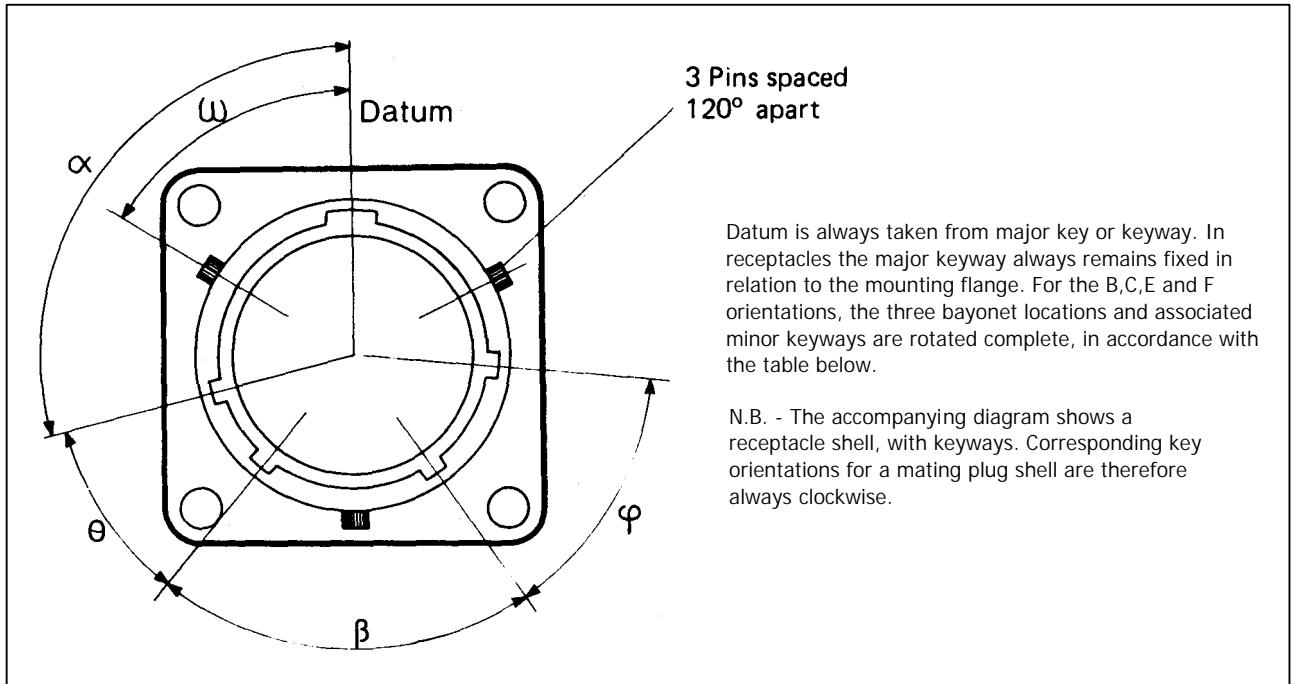

Shell Size	VALUES FOR a (degrees)					VALUES FOR q (degrees)					VALUES FOR b (degrees)				
	N	B	C	E	F	N	B	C	E	F	N	B	C	E	F
14	105	91	119	75	120	35	35	35	30	50	75	75	75	100	75
16	105	93	117	75	120	35	35	35	30	50	75	75	75	100	75
18	105	95	115	75	120	35	35	35	30	50	75	75	75	100	75
20	105	95	115	75	120	35	35	35	30	50	75	75	75	100	75
22	105	97	113	75	120	35	35	35	30	50	75	75	75	100	75
24	105	97	113	75	120	35	35	35	30	50	75	75	75	100	75

Shell Size	VALUES FOR j (degrees) ORIENTATION					VALUES FOR w (degrees) ORIENTATION				
	N	B	C	E	F	N	B	C	E	F
14	50	50	50	30	35	60	46	74	30	75
16	50	50	50	30	35	60	48	72	30	75
18	50	50	50	30	35	60	50	70	30	75
20	50	50	50	30	35	60	50	70	30	75
22	50	50	50	30	35	60	52	68	30	75
24	50	50	50	30	35	60	52	68	30	75

Size #10 Data Bus Contact Assembly Instructions

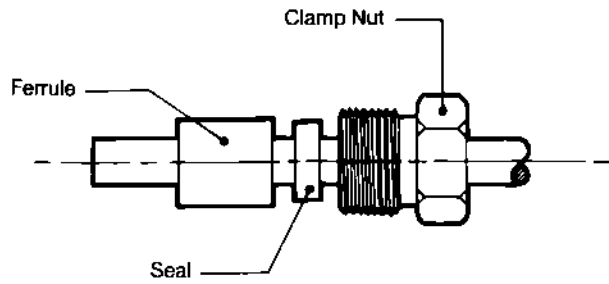

Slide clamp nut, seal and ferrule over cable. (Nut & seal only applicable on single way connector).

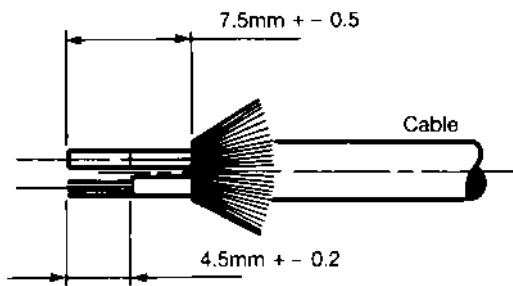

Remove outer sheath of cable to 7.5mm comb out all braids evenly and fold back. Remove cable fillers from stripped length. Strip the centre contact conductor to 4.5mm. Note: It is recommended that both intermediate and centre contact conductors are scored at the correct stripping length. The intermediate conductor insulation should not be removed until the centre contact has been crimped.

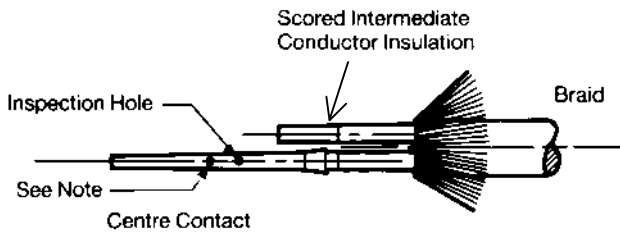

Crimp centre contact (Pin or Socket) on to the stripped wire using tool M22520/2-01 and crimp positioner 294GB-5027-1 (setting No. 4 for 24AWG) butting rear end of contact to wire insulation. The conductor end should be visible in the inspection hole. Note: A second hole is permissible in the socket contact for manufacturing purposes. It is not required to be on the same centre line as the inspection hole.

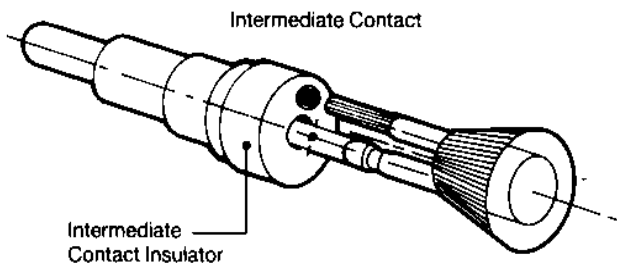

Strip intermediate contact conductor to 4.5mm. Insert centre contact into centre hole of intermediate contact conductor into the outer hole of the intermediate contact assembly. Push firmly home until the centre contact is felt to snap into place and ensure that the insulation of each conductor is fully inserted into the intermediate contact insulator. The intermediate conductor should be visible in the inspection hole in the intermediate contact. There should be no loose cable strands visible. Crimp the intermediate contact assembly using the appropriate cavity of crimp jaw 294GB-5026-1 fitted into M22520/5-01 tool.

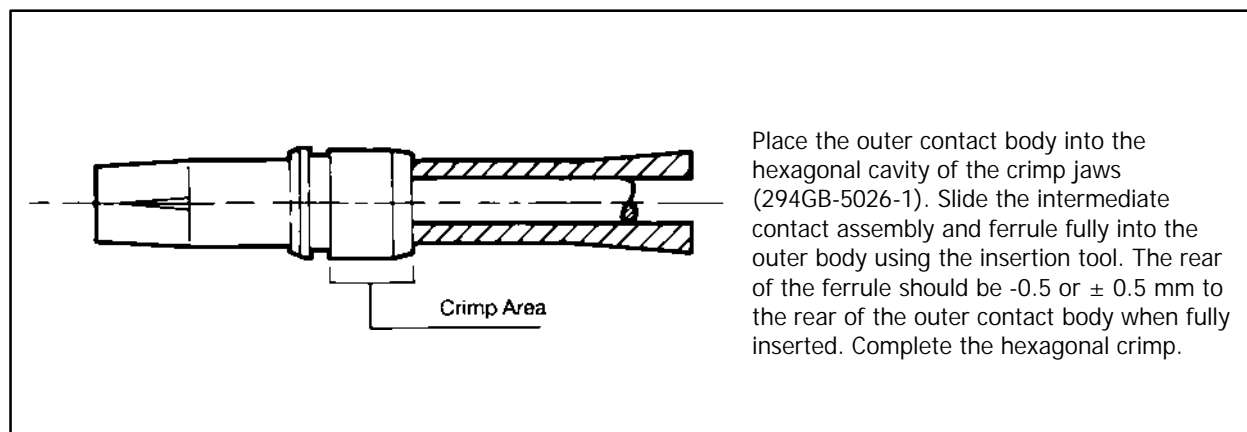
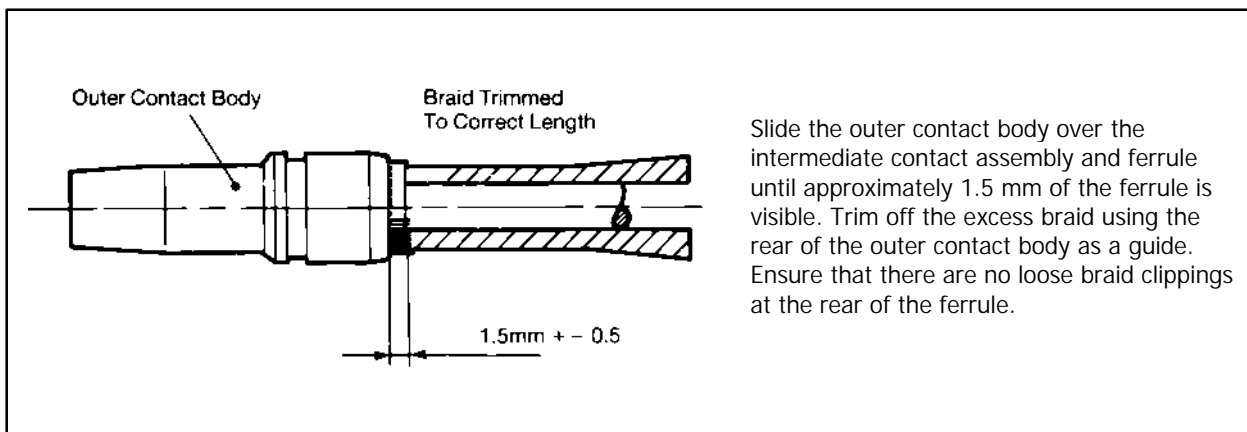
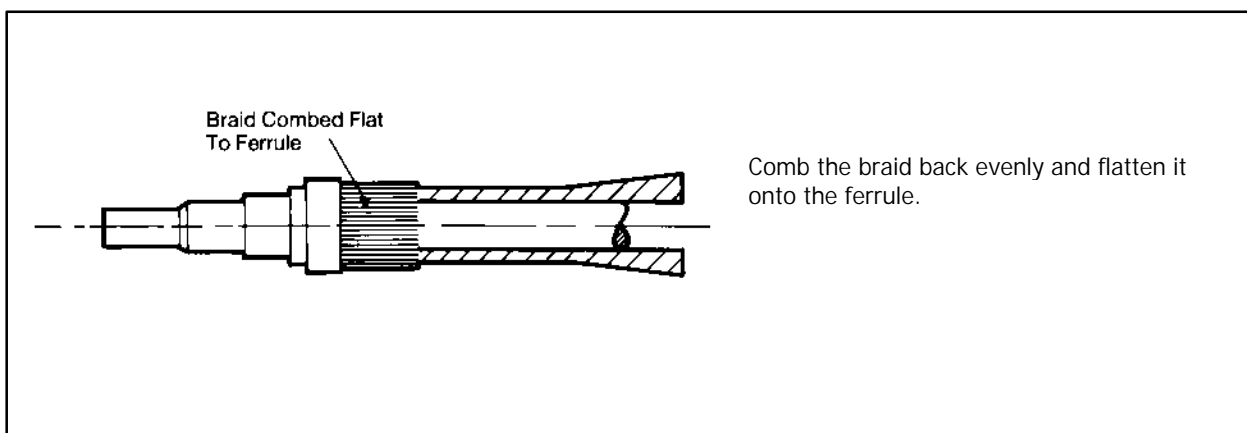
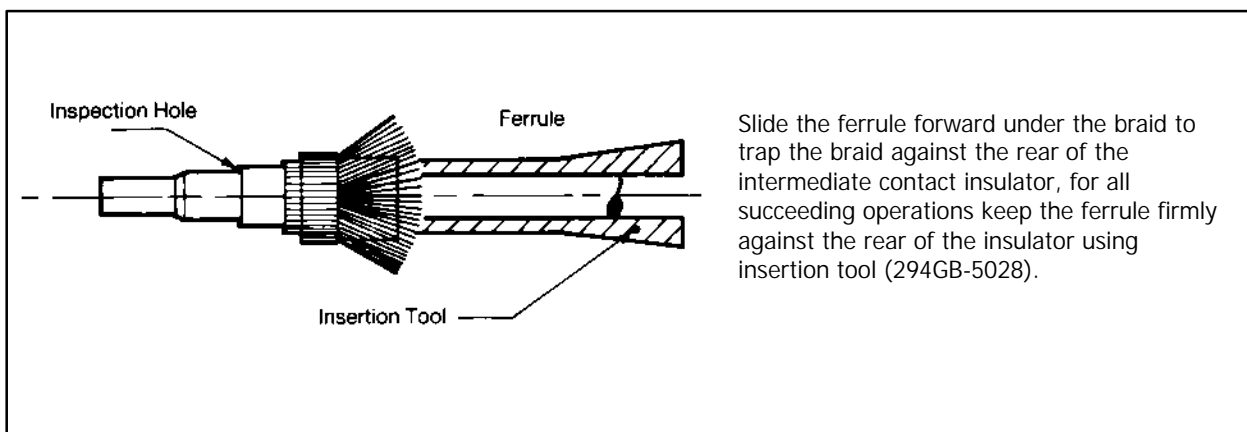



International Locations

EUROPE

Amphenol Limited
Thanet Way, Whitstable,
Kent CT5 3JF,
England.
Tel.: (0227) 264411
Telex: 96157
Fax: (0227)276571

Amphenol Italia S.P.A.
Galleria Gandhi 2/27
20017 Mazzo DI RHO
Milano
Tel: 392-935 03190
Fax: 392-935 03206

Amphenol Socapex France
21 Chemin du Defois
BP 349
39105 Dole Cedex
France
Tel: (3384) 829400
Telex: (842) 360264 F UMD B
Fax: (3384) 829411

Amphenol Espana
Galileo
303-305
4a Planta 080 28
Barcelona
Spain
Tel: (34/3) 321.00.00
Fax: (34/3) 439.89.27
Telex: 98253

Amphenol Gesellschaft mbH
Tautenhayngasse 22
A-1150 Wien (Vienna)
Austria
Tel: (0222) 95 15 11
Telex: 132661 amphw a
Fax: (0222) 92 61 01

Amphenol Benelux B.V.
P.O. Box 63
3990 DB Houten
The Netherlands
Phone: (31) 3403-76499
Fax: (31) 3403-77899
Telex: (844) 40794 AMPHL NL

Amphenol Scandinavia AB
Box 742
S-19427
Upplands
Vasby
Sweden
Tel: (0760) 880 35
Telex: 1 78 90 ampheus s
Fax: (0760) 338 00

Amphenol-Tuchel
Electronics GmbH
August-HaeuBer-Str. 10
7100 Heilbronn
W. Germany
Tel: (07131) 486-0
Telex: 728 223
Fax: (49-7131) 486323

FAR EAST

JAPAN

Nippon Interconnect Company
Head Office
2-3-27 Kudan Minami
Chiyoda-Ku Tokyo 102
Japan
Tel: (81-3) 263-5611
Telex: (781) 2324654 HQ NIC
Fax: (81-3) 239-5132

HONG KONG

Amphenol East Asia Limited
513-514 World Commerce Centre
Harbour City
11 Canton Road
TST, Kowloon
Hong Kong
Tel.: (3) 681283/4
Telex: 39289

Amphetronix Limited
Plot No. 105
Bhosari Industrial Area
Post Box No. 1
Poona 411026
India
Tel: 83363, 83463
Telex: 146237

CANADA

Amphenol Canada Corp.
20 Melford Drive
Scarborough, Ontario M1B 2X6
Canada
Tel.: (416) 291-4401
Telex: 065-25210
Fax: (416) 292-0647

USA AND OTHER INTERNATIONAL AREAS

Amphenol
World Headquarters
L.P.L Investment Group Inc.
P.O. Box 384
358 Hall Avenue
Wallingford
Connecticut
C.T. 06492
Tel: 203-265-8600
Fax: 203-265-8628

Bendix Connector Operations
40-60 Delaware Street
Sidney, New York 13838-1395
Tel.: (607) 563-5011
Fax: (607) 563-5157/5118

International Catalogue System



Amphenol products produced worldwide are shown in four product catalogue binders.

The International Catalogue for Amphenol products consists of an individual data catalogue for each product series produced world-wide. Product series are combined by product groups, and published in eight (8) separate condensed catalogues as listed below:

Catalogue	Number
Circular Environmental Connectors	CE-SF
Circular Industrial Connectors	CI-SF
Coaxial Connectors	CC-SF
Flat Ribbon Connectors	FR-SF
Printed Circuit Connectors	PC-SF
Rack and Panel (Rectangular) Connectors	RP-SF
Fibre Optics	-

Data catalogues contain a description of the product series, technical information, specification data, dimensions and part numbers. A data catalogue or a condensed catalogue can be obtained from any international location listed above. When ordering state the catalogue.



Seven Condensed Catalogues illustrate the products by series designation.

NOTICE

Products are sold subject to Amphenol's conditions of sale ("the standard conditions") All specifications and statements contained herein are believed to be correct at the time of printing, but no representation or warranty, express or implied, is given as to any specification or statement contained herein Product specifications including performance characteristics are typical only and subject to deviation Specifications are also subject to change without notice. User should not assume that all safety measures are indicated or that other measures may not be required No representation or warranty, express or implied, is given that any use of products (including any stated or suggested use) does not infringe any patent, registered design or other third party rights and no stated or suggested use of products can be taken to recommend any such infringement

Amphenol