



2M (128K x 16) Static RAM

Features

- Very high speed: 55 ns and 70 ns
- Voltage range:
 - CY62136CV30: 2.7V–3.3V
 - CY62136CV33: 3.0V–3.6V
 - CY62136CV: 2.7V–3.6V
- Pin-compatible with the CY62136V
- Ultra-low active power
 - Typical active current: 1.5 mA @ f = 1 MHz
 - Typical active current: 5.5 mA @ f = f_{max} (70-ns speed)
- Low standby power
- Easy memory expansion with \overline{CE} and \overline{OE} features
- Automatic power-down when deselected
- CMOS for optimum speed/power
- Packages offered in a 48-ball FBGA

Functional Description^[1]

The \overline{CE} and CY62136CV are high-performance CMOS static RAM organized as 128K words by 16 bits. This device features advanced circuit design to provide ultra-low active current.

This is ideal for providing More Battery Life™ (MoBL[®]) in portable applications such as cellular telephones. The device also has an automatic power-down feature that significantly reduces power consumption by 80% when addresses are not toggling. The device can also be put into standby mode reducing power consumption by more than 99% when deselected (\overline{CE} HIGH). The input/output pins (I/O₀ through I/O₁₅) are placed in a high-impedance state when: deselected (\overline{CE} HIGH), outputs are disabled (\overline{OE} HIGH), both Byte High Enable and Byte Low Enable are disabled (\overline{BHE} , BLE HIGH), or during a write operation (\overline{CE} LOW, and \overline{WE} LOW).

Writing to the device is accomplished by taking Chip Enable (\overline{CE}) and Write Enable (\overline{WE}) inputs LOW. If Byte Low Enable (BLE) is LOW, then data from I/O pins (I/O₀ through I/O₇), is written into the location specified on the address pins (A₀ through A₁₆). If Byte High Enable (\overline{BHE}) is LOW, then data from I/O pins (I/O₈ through I/O₁₅) is written into the location specified on the address pins (A₀ through A₁₆).

Reading from the device is accomplished by taking Chip Enable (\overline{CE}) and Output Enable (\overline{OE}) LOW while forcing the Write Enable (\overline{WE}) HIGH. If Byte Low Enable (BLE) is LOW, then data from the memory location specified by the address pins will appear on I/O₀ to I/O₇. If Byte High Enable (\overline{BHE}) is LOW, then data from memory will appear on I/O₈ to I/O₁₅. See the truth table at the back of this data sheet for a complete description of read and write modes.

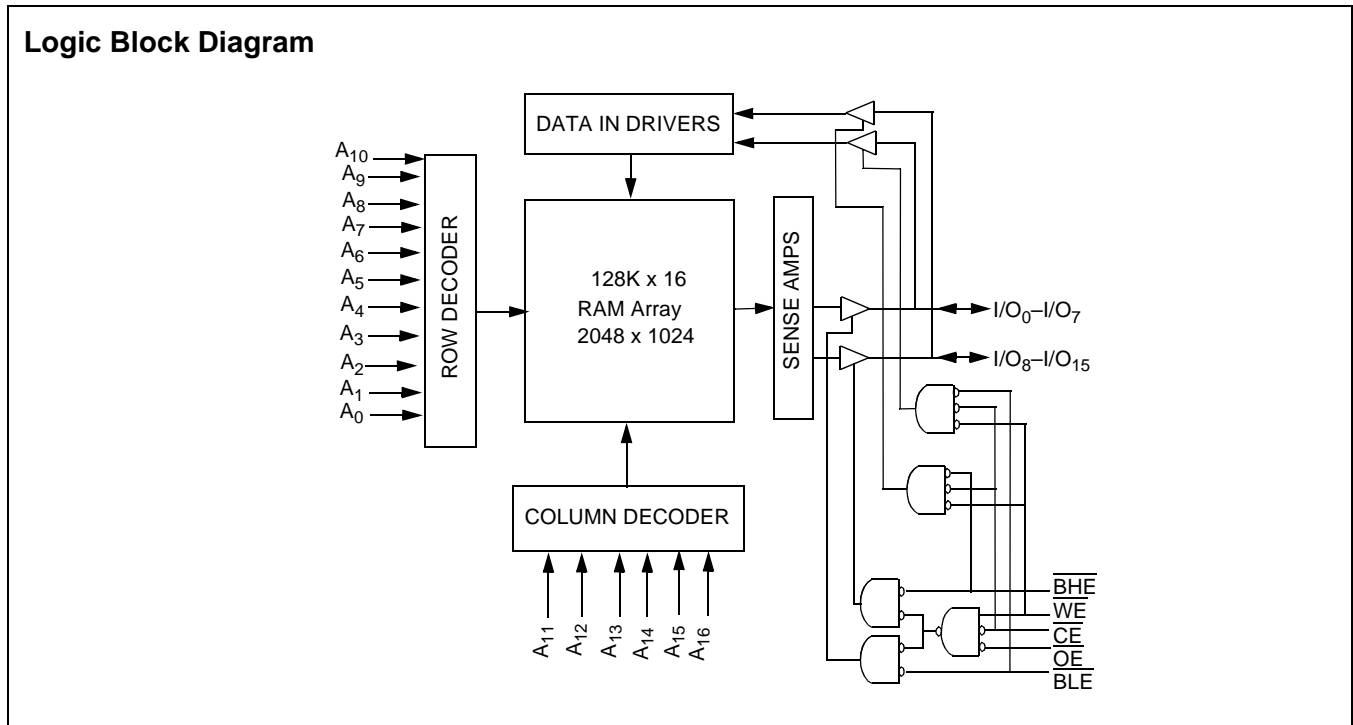

Note:

1. For best practice recommendations, please refer to the Cypress application note "System Design Guidelines" on <http://www.cypress.com>.

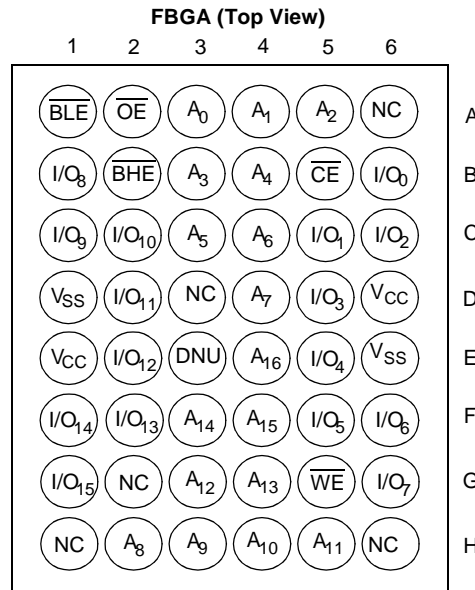
Pin Configuration^[2, 3]

Maximum Ratings

(Above which the useful life may be impaired. For user guidelines, not tested.)

- Storage Temperature -65°C to +150°C
- Ambient Temperature with Power Applied -55°C to +125°C
- Supply Voltage to Ground Potential -0.5V to V_{CCMAX} + 0.5V
- DC Voltage Applied to Outputs in High-Z State^[4] -0.5V to V_{CC} + 0.3V
- DC Input Voltage^[4] -0.5V to V_{CC} + 0.3V
- Output Current into Outputs (LOW) 20 mA

Static Discharge Voltage..... > 2001V (per MIL-STD-883, Method 3015)

Latch-up Current..... > 200 mA

Operating Range

Device	Range	Ambient Temperature	V _{CC}
CY62136CV30	Industrial	-40°C to +85°C	2.7V to 3.3V
CY62136CV33			3.0V to 3.6V
CY62136CV			2.7V to 3.6V

Product Portfolio

Product	V _{CC} Range (V)			Speed (ns)	Power Dissipation							
					Operating, I _{CC} (mA)				Standby, I _{SB2} (μA)			
	V _{CC(min.)}	V _{CC(typ.)} ^[5]	V _{CC(max.)}		f = 1 MHz		f = f _{max}		Typ. ^[5]		Max.	
					Typ. ^[5]	Max.	Typ. ^[5]	Max.	Typ. ^[5]	Max.		
CY62136CV30LL	2.7	3.0	3.3	55	1.5	3	7	15	2	10		
				70	1.5	3	5.5	12				
CY62136CV33LL	3.0	3.3	3.6	55	1.5	3	7	15	5	15		
				70	1.5	3	5.5	12				
CY62136CVLL	2.7	3.3	3.6	70	1.5	3	5.5	12	5	15		

Notes:

2. NC pins are not connected to the die.
3. E3 (DNU) can be left as NC or V_{SS} to ensure proper application.
4. V_{IL(min.)} = -2.0V for pulse durations less than 20 ns.
5. Typical values are included for reference only and are not guaranteed or tested. Typical values are measured at V_{CC} = V_{CC(typ.)}, T_A = 25°C.



Electrical Characteristics Over the Operating Range

Parameter	Description	Test Conditions	CY62136CV30-55			CY62136CV30-70			Unit
			Min.	Typ. ^[5]	Max.	Min.	Typ. ^[5]	Max.	
V _{OH}	Output HIGH Voltage	I _{OH} = -1.0 mA V _{CC} = 2.7V	2.4			2.4			V
V _{OL}	Output LOW Voltage	I _{OL} = 2.1 mA V _{CC} = 2.7V			0.4			0.4	V
V _{IH}	Input HIGH Voltage		2.2		V _{CC} +0.3V	2.2		V _{CC} +0.3V	V
V _{IL}	Input LOW Voltage		-0.3		0.8	-0.3		0.8	V
I _{IX}	Input Leakage Current	GND ≤ V _I ≤ V _{CC}	-1		+1	-1		+1	μA
I _{OZ}	Output Leakage Current	GND ≤ V _O ≤ V _{CC} , Output Disabled	-1		+1	-1		+1	μA
I _{CC}	V _{CC} Operating Supply Current	f = f _{MAX} = 1/t _{RC} f = 1 MHz		7	15		5.5	12	mA
		V _{CC} = 3.3V I _{OUT} = 0 mA CMOS Levels		1.5	3		1.5	3	
I _{SB1}	Automatic CE Power-down Current — CMOS Inputs	CE ≥ V _{CC} - 0.2V V _{IN} ≥ V _{CC} - 0.2V or V _{IN} ≤ 0.2V, f = f _{max} (Address and Data Only), f = 0 (OE, WE, BHE, and BLE)		2	10		2	10	μA
I _{SB2}	Automatic CE Power-down Current — CMOS Inputs	CE ≥ V _{CC} - 0.2V V _{IN} ≥ V _{CC} - 0.2V or V _{IN} ≤ 0.2V, f = 0, V _{CC} = 3.3V							

Parameter	Description	Test Conditions	CY62136CV33-55			CY62136CV33-70 CY62136CV-70			Unit
			Min.	Typ. ^[5]	Max.	Min.	Typ. ^[5]	Max.	
V _{OH}	Output HIGH Voltage	I _{OH} = -1.0 mA V _{CC} = 3.0V V _{CC} = 2.7V	2.4			2.4			V
						2.4			V
V _{OL}	Output LOW Voltage	I _{OL} = 2.1 mA V _{CC} = 3.0V V _{CC} = 2.7V			0.4			0.4	V
								0.4	V
V _{IH}	Input HIGH Voltage		2.2		V _{CC} +0.3V	2.2		V _{CC} +0.3V	V
V _{IL}	Input LOW Voltage		-0.3		0.8	-0.3		0.8	V
I _{IX}	Input Leakage Current	GND ≤ V _I ≤ V _{CC}	-1		+1	-1		+1	μA
I _{OZ}	Output Leakage Current	GND ≤ V _O ≤ V _{CC} , Output Disabled	-1		+1	-1		+1	μA
I _{CC}	V _{CC} Operating Supply Current	f = f _{MAX} = 1/t _{RC} f = 1 MHz		7	15		5.5	12	mA
		V _{CC} = 3.6V I _{OUT} = 0 mA CMOS Levels		1.5	3		1.5	3	
I _{SB1}	Automatic CE Power-down Current — CMOS Inputs	CE ≥ V _{CC} - 0.2V V _{IN} ≥ V _{CC} - 0.2V or V _{IN} ≤ 0.2V, f = f _{max} (Address and Data Only), f = 0 (OE, WE, BHE, and BLE)		5	15		5	15	μA
I _{SB2}	Automatic CE Power-down Current — CMOS Inputs	CE ≥ V _{CC} - 0.2V V _{IN} ≥ V _{CC} - 0.2V or V _{IN} ≤ 0.2V, f = 0, V _{CC} = 3.6V							

Capacitance^[6]

Parameter	Description	Test Conditions	Max.	Unit
C _{IN}	Input Capacitance	T _A = 25°C, f = 1 MHz, V _{CC} = V _{CC(typ.)}	6	pF
C _{OUT}	Output Capacitance		8	pF

Thermal Resistance

Parameter	Description	Test Conditions	BGA	Unit
Θ_{JA}	Thermal Resistance (Junction to Ambient) ^[6]	Still Air, soldered on a 3 x 4.5 inch, two-layer printed circuit board	55	°C/W
Θ_{JC}	Thermal Resistance (Junction to Case) ^[6]		16	°C/W

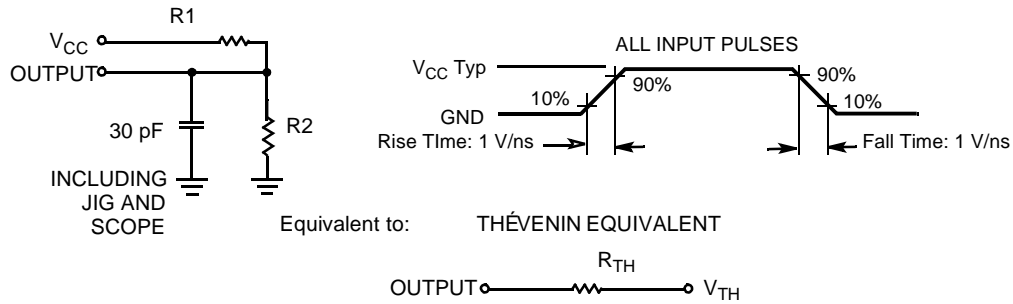
AC Test Loads and Waveforms

Parameters	3.0V	3.3V	Unit
R1	1105	1216	Ω
R2	1550	1374	Ω
R_{TH}	645	645	Ω
V_{TH}	1.75	1.75	V

Data Retention Characteristics (Over the Operating Range)

Parameter	Description	Conditions	Min.	Typ. ^[5]	Max.	Unit
V_{DR}	V_{CC} for Data Retention		1.5		V_{CCmax}	V
I_{CCDR}	Data Retention Current	$V_{CC} = 1.5V$ $\overline{CE} \geq V_{CC} - 0.2V$, $V_{IN} \geq V_{CC} - 0.2V$ or $V_{IN} \leq 0.2V$		1	6	μA
$t_{CDR}^{[6]}$	Chip Deselect to Data Retention Time		0			ns
$t_R^{[7]}$	Operation Recovery Time		t_{RC}			ns

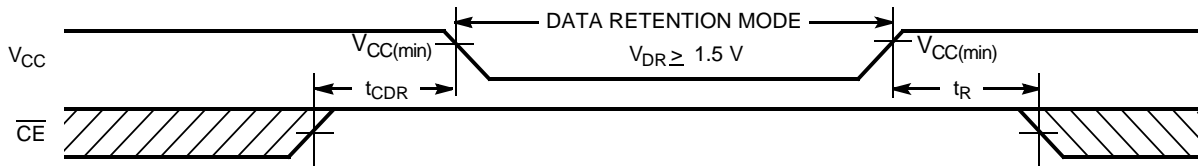
Data Retention Waveform

Notes:

6. Tested initially and after any design or process changes that may affect these parameters.
7. Full Device AC operation requires linear V_{CC} ramp from V_{DR} to $V_{CC(min.)} > 100 \mu s$ or stable at $V_{CC(min.)} > 100 \mu s$.



Switching Characteristics Over the Operating Range^[8]

Parameter	Description	55 ns		70 ns		Unit
		Min.	Max.	Min.	Max.	
Read Cycle						
t _{RC}	Read Cycle Time	55		70		ns
t _{AA}	Address to Data Valid		55		70	ns
t _{OHA}	Data Hold from Address Change	10		10		ns
t _{ACE}	CE LOW to Data Valid		55		70	ns
t _{DOE}	OE LOW to Data Valid		25		35	ns
t _{LZOE}	OE LOW to Low-Z ^[9]	5		5		ns
t _{HZOE}	OE HIGH to High-Z ^[9, 10]		20		25	ns
t _{LZCE}	CE LOW to Low-Z ^[9]	10		10		ns
t _{HZCE}	CE HIGH to High-Z ^[9, 10]		20		25	ns
t _{PU}	CE LOW to Power-up	0		0		ns
t _{PD}	CE HIGH to Power-down		55		70	ns
t _{DBE}	BHE/BL _E LOW to Data Valid		25		35	ns
t _{LZBE}	BHE/BL _E LOW to Low-Z ^[9]	5		5		ns
t _{HZBE}	BHE/BL _E HIGH to High-Z ^[9, 10]		20		25	ns
Write Cycle^[11]						
t _{WC}	Write Cycle Time	55		70		ns
t _{SCE}	CE LOW to Write End	45		60		ns
t _{AW}	Address Set-up to Write End	45		60		ns
t _{HA}	Address Hold from Write End	0		0		ns
t _{SA}	Address Set-up to Write Start	0		0		ns
t _{PWE}	WE Pulse Width	40		45		ns
t _{BW}	BHE/BL _E Pulse Width	50		60		ns
t _{SD}	Data Set-up to Write End	25		30		ns
t _{HD}	Data Hold from Write End	0		0		ns
t _{HZWE}	WE LOW to High-Z ^[9, 10]		20		25	ns
t _{LZWE}	WE HIGH to Low-Z ^[9]	10		10		ns

Switching Waveforms

Read Cycle No. 1 (Address Transition Controlled)^[12, 13]

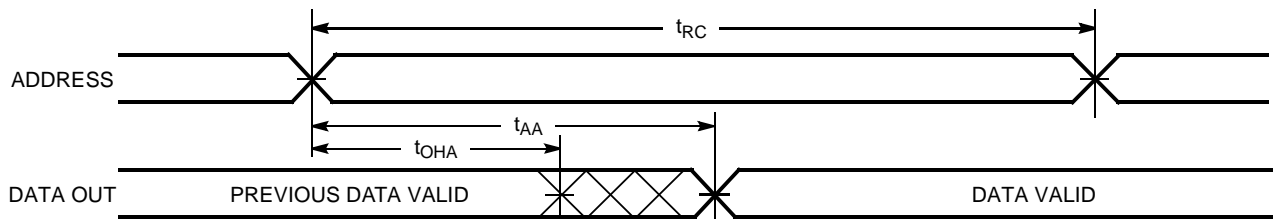

Notes:

- Test conditions assume signal transition time of 5 ns or less, timing reference levels of $V_{CC(typ.)}/2$, input pulse levels of 0 to $V_{CC(typ.)}$, and output loading of the specified I_{OL}/I_{OH} and 30-pF load capacitance.
- At any given temperature and voltage condition, t_{HZCE} is less than t_{LZCE} , t_{HZBE} is less than t_{LZBE} , t_{HZOE} is less than t_{LZOE} , and t_{HZWE} is less than t_{LZWE} for any given device.
- t_{HZOE} , t_{HZCE} , t_{HZBE} , and t_{HZWE} transitions are measured when the outputs enter a high-impedance state.
- The internal write time of the memory is defined by the overlap of \overline{WE} , $\overline{CE} = V_{IL}$, \overline{BHE} and/or $\overline{BLE} = V_{IL}$. All signals must be ACTIVE to initiate a write and any of these signals can terminate a write by going INACTIVE. The data input set-up and hold timing should be referenced to the edge of the signal that terminates the write.
- Device is continuously selected. \overline{OE} , $\overline{CE} = V_{IL}$, \overline{BHE} , $\overline{BLE} = V_{IL}$.
- \overline{WE} is HIGH for read cycle.

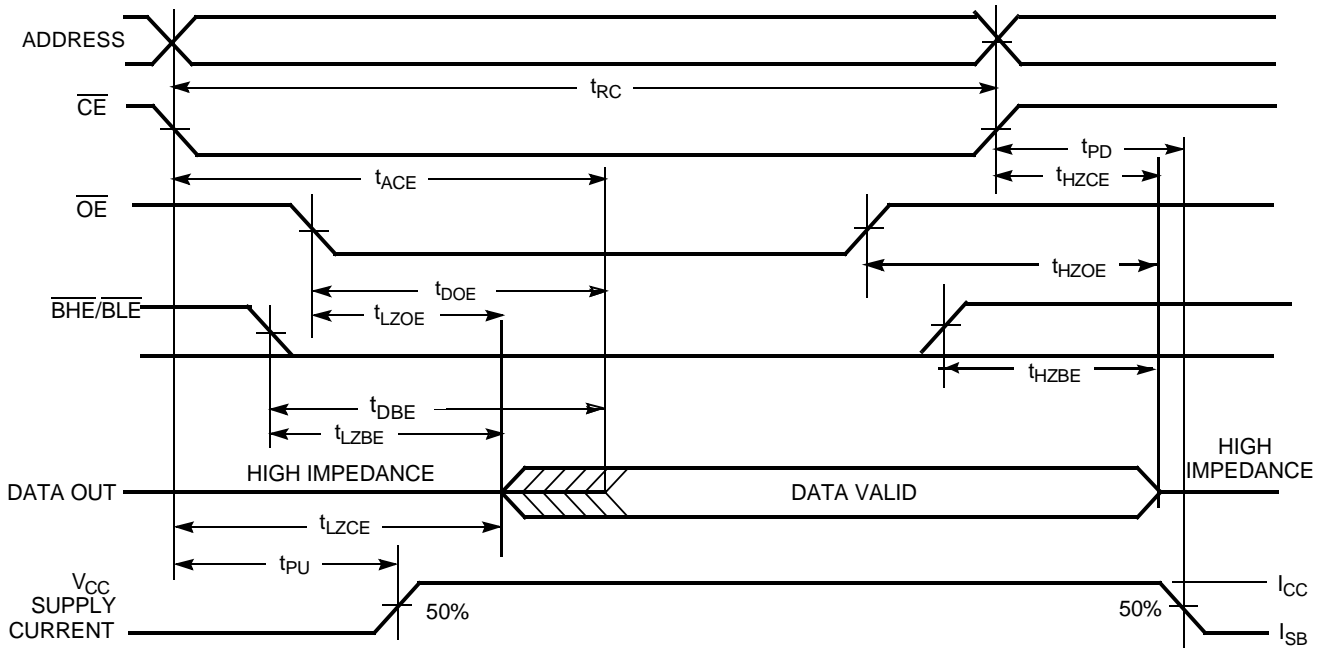
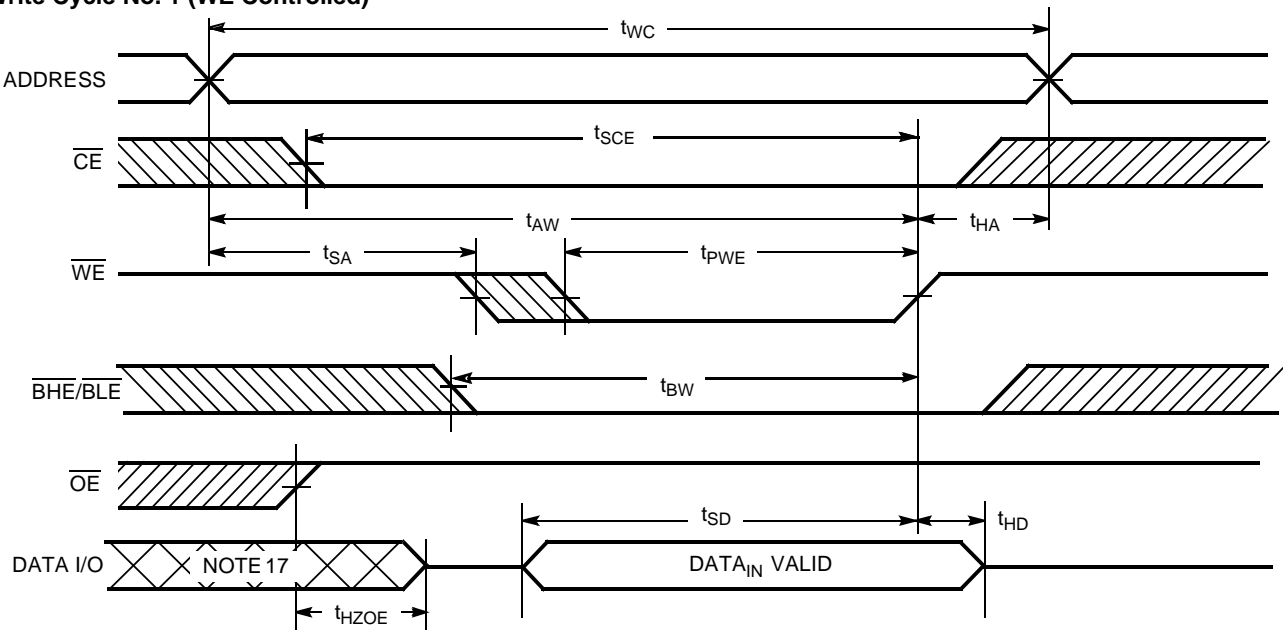
Switching Waveforms (continued)
Read Cycle No. 2 (\overline{OE} Controlled) [13, 14]

Write Cycle No. 1 (\overline{WE} Controlled) [11, 15, 16]

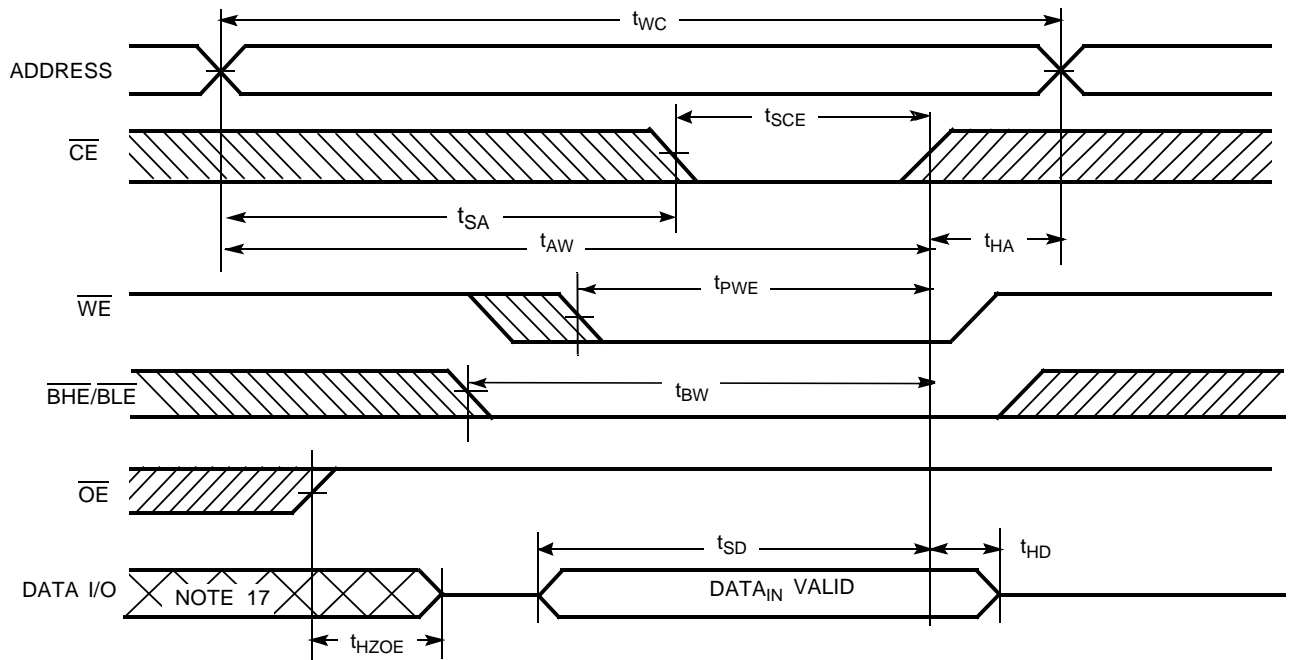
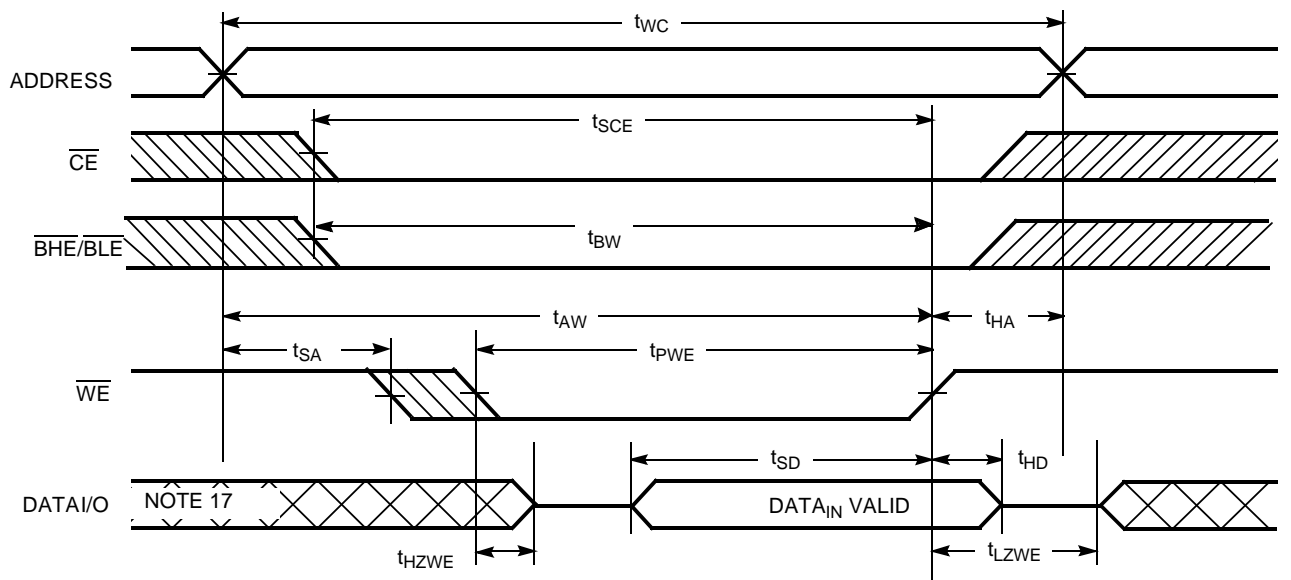
Notes:

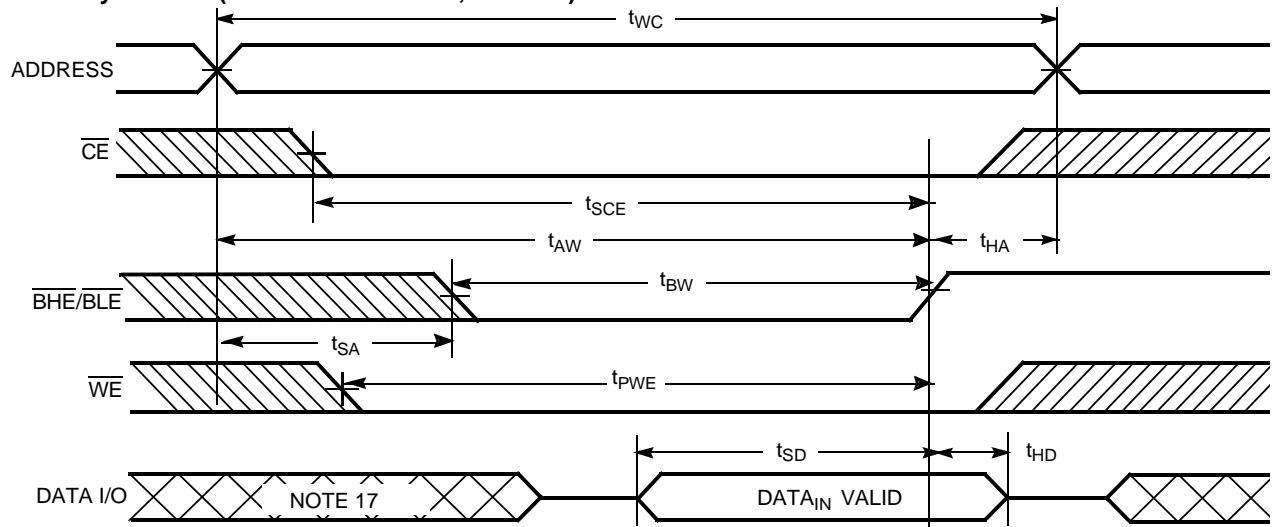
14. Address valid prior to or coincident with \overline{CE} , \overline{BHE} , \overline{BLE} transition LOW.
15. Data I/O is high-impedance if $\overline{OE} = V_{IH}$.
16. If \overline{CE} goes HIGH simultaneously with \overline{WE} HIGH, the output remains in a high-impedance state.
17. During this period, the I/Os are in output state and input signals should not be applied.

Switching Waveforms (continued)
Write Cycle No. 2 (\overline{CE} Controlled) ^[11, 15, 16]

Write Cycle No. 3 (\overline{WE} Controlled, \overline{OE} LOW) ^[16]

Switching Waveforms (continued)
Write Cycle No. 4 ($\overline{\text{BHE}}/\overline{\text{BLE}}$ Controlled, $\overline{\text{OE}}$ LOW)^[16]

Typical DC and AC Parameters

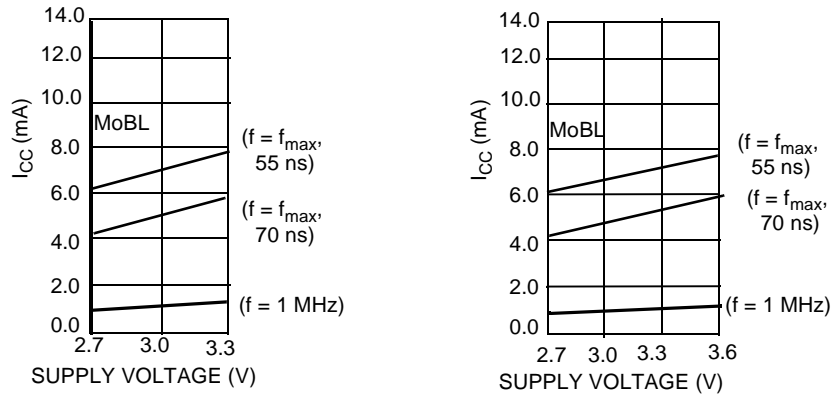
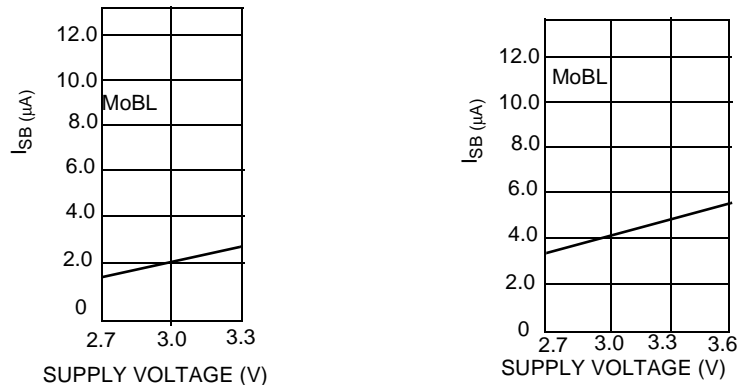
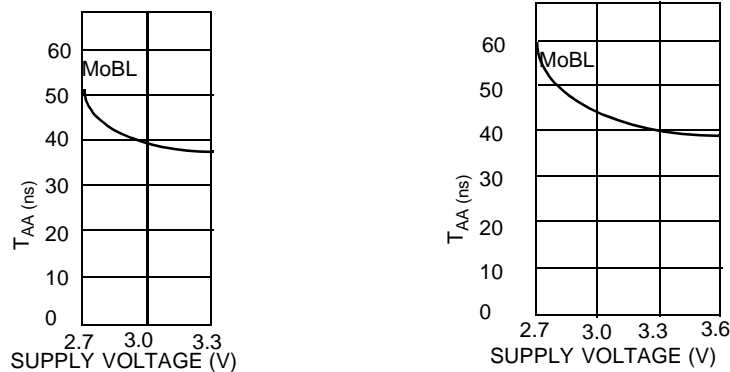
(Typical values are included for reference only and are not guaranteed or tested. Typical values are measured at $V_{CC} = V_{CC(typ.)}$, $T_A = 25^\circ\text{C}$)

Operating Current vs. Supply Voltage

Standby Current vs. Supply Voltage

Access Time vs. Supply Voltage

Truth Table

$\overline{\text{CE}}$	$\overline{\text{WE}}$	$\overline{\text{OE}}$	$\overline{\text{BHE}}$	$\overline{\text{BLE}}$	Inputs/Outputs	Mode	Power
H	X	X	X	X	High-Z	Deselect/Power-down	Standby (I_{SB})
L	X	X	H	H	High-Z	Output Disabled	Active (I_{CC})
L	H	L	L	L	Data Out (I/O_0 – I/O_{15})	Read	Active (I_{CC})
L	H	L	H	L	Data Out (I/O_0 – I/O_7); I/O_8 – I/O_{15} in High-Z	Read	Active (I_{CC})
L	H	L	L	H	Data Out (I/O_8 – I/O_{15}); I/O_0 – I/O_7 in High-Z	Read	Active (I_{CC})
L	H	H	L	L	High-Z	Output Disabled	Active (I_{CC})



Truth Table (continued)

\overline{CE}	\overline{WE}	\overline{OE}	\overline{BHE}	\overline{BLE}	Inputs/Outputs	Mode	Power
L	H	H	H	L	High-Z	Output Disabled	Active (I_{CC})
L	H	H	L	H	High-Z	Output Disabled	Active (I_{CC})
L	L	X	L	L	Data In (I/O_0 – I/O_{15})	Write	Active (I_{CC})
L	L	X	H	L	Data In (I/O_0 – I/O_7); I/O_8 – I/O_{15} in High-Z	Write	Active (I_{CC})
L	L	X	L	H	Data In (I/O_8 – I/O_{15}); I/O_0 – I/O_7 in High-Z	Write	Active (I_{CC})

Ordering Information

Speed (ns)	Ordering Code	Voltage Range (V)	Package Name	Package Type	Operating Range
70	CY62136CV30LL-70BAI	2.7–3.3	BA48A	48-ball Fine Pitch BGA (7 mm x 7 mm x 1.2 mm)	Industrial
	CY62136CV30LL-70BVI	2.7–3.3	BV48A	48-ball Fine Pitch BGA (6 mm x 8 mm x 1 mm)	
	CY62136CV33LL-70BAI	3.0–3.6	BA48A	48-ball Fine Pitch BGA (7 mm x 7 mm x 1.2 mm)	
	CY62136CV33LL-70BVI	3.0–3.6	BV48A	48-ball Fine Pitch BGA (6 mm x 8 mm x 1 mm)	
	CY62136CVLL-70BAI	2.7–3.6	BA48A	48-ball Fine Pitch BGA (7 mm x 7 mm x 1.2 mm)	
	CY62136CVLL-70BVI	2.7–3.6	BV48A	48-ball Fine Pitch BGA (6 mm x 8 mm x 1 mm)	
55	CY62136CV30LL-55BAI	2.7–3.3	BA48A	48-ball Fine Pitch BGA (7 mm x 7 mm x 1.2 mm)	
	CY62136CV30LL-55BVI	2.7–3.3	BV48A	48-ball Fine Pitch BGA (6 mm x 8 mm x 1 mm)	
	CY62136CV33LL-55BAI	3.0–3.6	BA48A	48-ball Fine Pitch BGA (7 mm x 7 mm x 1.2 mm)	
	CY62136CV33LL-55BVI	3.0–3.6	BV48A	48-ball Fine Pitch BGA (6 mm x 8 mm x 1 mm)	

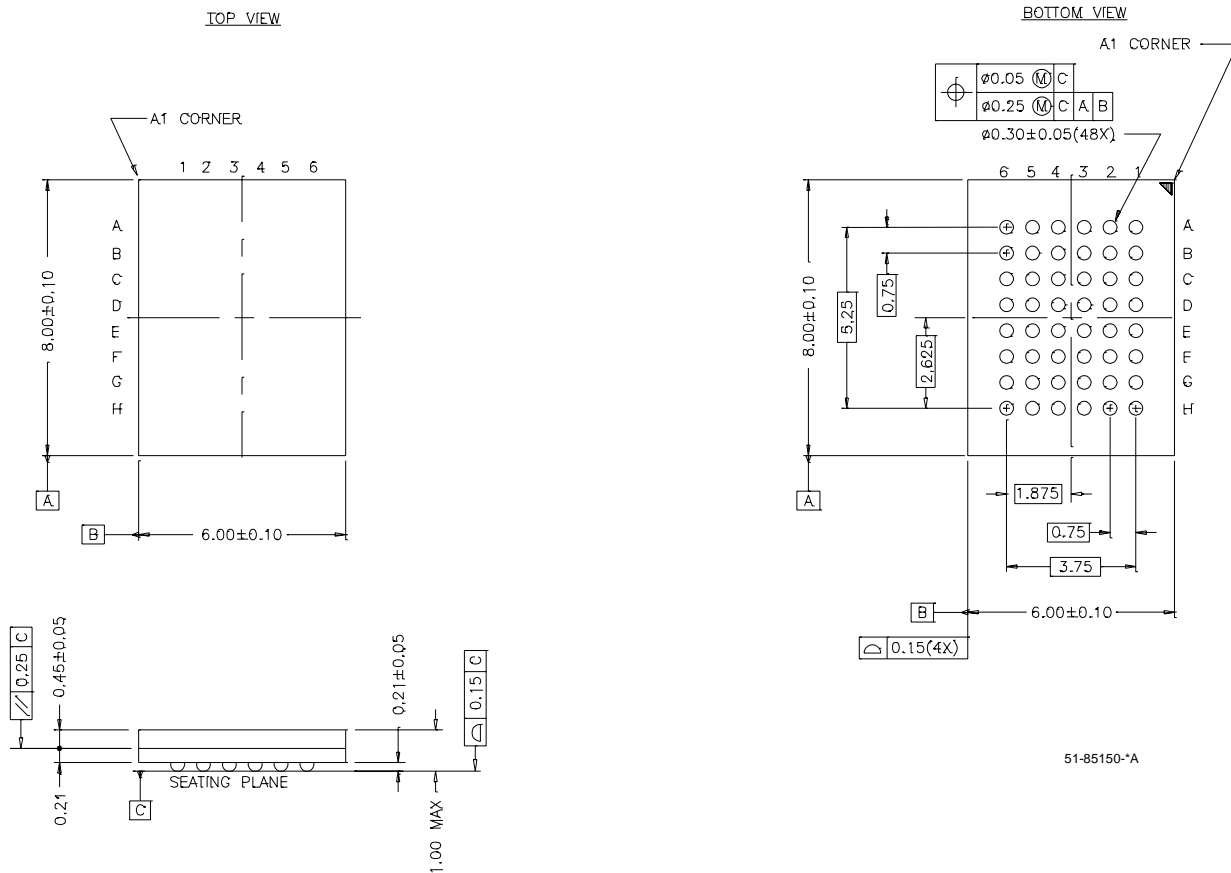
Package Diagrams (continued)
48-ball VFBGA (6 x 8 x 1 mm) BV48A

MoBL is a registered trademark and More Battery Life is a trademark of Cypress Semiconductor Corporation. All product and company names mentioned in this document may be the trademarks of their respective holders.



Document History Page

Document Title: CY62136CV30/33/CY62136CV/CY62136CV30/33 2M (128K x 16) Static RAM				
Document Number: 38-05199				
REV.	ECN NO.	Issue Date	Orig. of Change	Description of Change
**	112379	02/19/02	GAV	New Data Sheet (advance information)
*A	114023	04/25/02	JUI	Added BV package diagram Changed Advance Information to Preliminary
*B	117063	07/12/02	MGN	Changed Preliminary to Final
*C	118121	08/26/02	MGN	Added new part numbers: CY62136CV with wider voltage (2.7V – 3.6V); CY62136CV33 narrower voltage range (3.0V – 3.6V) For T _{AA} = 55 ns, improved t _{PWE} Min from 45 ns to 40 ns For T _{AA} = 70 ns, improved t _{PWE} Min from 50 ns to 45 ns For T _{AA} = 70 ns, improved t _{LZWE} Min from 5 ns to 10 ns
*D	118622	10/3/02	MGN	Improved Typ. I _{CC} spec. to 7 mA (for 55 ns) and 5.5 mA (for 70 ns) Improved Max I _{CC} spec. to 15 mA (for 55 ns) and 12 mA (for 70 ns) For T _{AA} = 55 ns, improved t _{LZWE} min. from 5 ns to 10 ns Changed upper spec. for Supply Voltage to Ground Potential to V _{CCMAX} + 0.5V Changed upper spec. for DC Voltage Applied to Outputs in High-Z State and DC Input Voltage to V _{CC} + 0.3V