

Silicon NPN Planar RF Transistor

Electrostatic sensitive device.
Observe precautions for handling.



Applications

RF-amplifier up to GHz range specially for wide band antenna amplifier.

Features

- High power gain
- Low noise figure
- High transition frequency

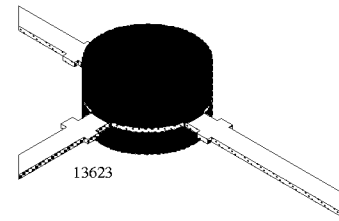
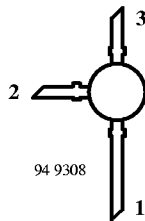

BFR90A Marking: BFR90A

Plastic case (TO 50)

1= Collector; 2= Emitter; 3= Base

Absolute Maximum Ratings

Parameters	Symbol	Value	Unit
Collector-base voltage	V_{CBO}	20	V
Collector-emitter voltage	V_{CEO}	15	V
Emitter-base voltage	V_{EBO}	2	V
Collector current	I_C	30	mA
Total power dissipation $T_{amb} \leq 60^\circ\text{C}$	P_{tot}	300	mW
Junction temperature	T_j	150	$^\circ\text{C}$
Storage temperature range	T_{stg}	-65 to +150	$^\circ\text{C}$

Maximum Thermal Resistance

Parameters	Symbol	Value	Unit
Junction ambient on glass fibre printed board (40 x 25 x 1.5) mm ³ plated with 35 μm Cu	R_{thJA}	300	K/W

Electrical DC Characteristics

T_j = 25°C, unless otherwise specified

Parameters / Test Conditions	Symbol	Min.	Typ.	Max.	Unit
Collector-emitter cut-off current V _{CE} = 20 V, V _{BE} = 0	I _{CES}			100	μA
Collector-base cut-off current V _{CB} = 15 V, I _E = 0	I _{CBO}			100	nA
Emitter-base cut-off current V _{EB} = 2 V, I _C = 0	I _{EBO}			10	μA
Collector-emitter breakdown voltage I _C = 1 mA, I _B = 0	V _{(BR)CEO}	15			V
DC forward current transfer ratio V _{CE} = 10 V, I _C = 14 mA	h _{FE}	50	100	150	

Electrical AC Characteristics

T_{amb} = 25°C

Parameters / Test Conditions	Symbol	Min.	Typ.	Max.	Unit
Transition frequency V _{CE} = 10 V, I _C = 14 mA, f = 500 MHz	f _T		6		GHz
Collector-emitter capacitance V _{CE} = 10 V, f = 1 MHz	C _{ce}		0.25		pF
Collector-base capacitance V _{CB} = 10 V, f = 1 MHz	C _{cb}		0.3		pF
Emitter-base capacitance V _{EB} = 0.5 V, f = 1 MHz	C _{eb}		0.9		pF
Noise figure V _{CE} = 10 V, I _C = 2 mA, f = 800 MHz, Z _S = 50 Ω	F		1.8		dB
Power gain V _{CE} = 10 V, I _C = 14 mA, Z _L = Z _{Lopt} , f = 800 MHz	G _{pe}		16		dB
Linear output voltage – two tone intermodulation test V _{CE} = 10 V, I _C = 14 mA, d _{IM} = 60 dB, Z _S = Z _L = 50 Ω, f ₁ = 806 MHz, f ₂ = 810 MHz	V ₁ = V ₂		120		mV
Third order intercept point V _{CE} = 10 V, I _C = 14 mA, f = 800 MHz	IP ₃		24		dBm

Common Emitter S-Parameters

$Z_0 = 50 \Omega$

V_{CE}/V	I_C/mA	f/MHz	S_{11}		S_{21}		S_{12}		S_{22}	
			LIN MAG	ANG	LIN MAG	ANG	LIN MAG	ANG	LIN MAG	ANG
				deg		deg		deg		deg
5	2	100	0.90	-17.7	6.25	165.4	0.02	81.1	0.98	-6.8
		300	0.80	-50.4	5.51	140.9	0.05	65.5	0.91	-18.2
		500	0.67	-78.1	4.66	121.6	0.07	56.7	0.84	-25.8
		800	0.52	-111.2	3.56	99.9	0.08	51.2	0.77	-33.8
		1000	0.45	-128.8	2.99	89.0	0.09	51.0	0.75	-38.4
		1200	0.40	-144.1	2.58	80.3	0.10	52.1	0.74	-42.7
		1500	0.34	-164.2	2.11	69.3	0.11	54.6	0.74	-49.4
		1800	0.30	176.6	1.80	59.3	0.12	57.8	0.75	-56.3
	2000	0.28	165.9	1.64	54.2	0.13	59.4	0.76	-61.0	
	5	100	0.77	-27.0	13.24	156.9	0.02	76.2	0.95	-10.9
		300	0.56	-69.4	9.72	125.0	0.04	63.9	0.79	-23.5
		500	0.41	-97.4	7.01	106.7	0.05	61.8	0.70	-28.5
		800	0.30	-126.9	4.76	89.9	0.07	63.5	0.65	-34.1
		1000	0.26	-142.7	3.89	81.8	0.08	64.6	0.64	-38.3
		1200	0.24	-155.8	3.29	75.1	0.10	65.7	0.63	-42.5
		1500	0.21	-174.3	2.67	66.5	0.12	66.2	0.64	-49.3
		1800	0.19	167.7	2.27	58.1	0.14	66.0	0.66	-56.2
	2000	0.18	158.7	2.06	53.8	0.16	65.5	0.67	-60.6	
	10	100	0.61	-38.3	20.89	147.5	0.02	74.8	0.89	-15.0
		300	0.36	-85.3	12.29	113.4	0.03	67.7	0.68	-24.6
		500	0.26	-111.7	8.10	98.2	0.05	69.4	0.61	-27.5
		800	0.20	-139.9	5.28	84.9	0.07	71.4	0.58	-32.8
		1000	0.18	-154.3	4.28	78.0	0.08	71.8	0.58	-37.0
		1200	0.17	-166.5	3.61	72.3	0.10	71.6	0.58	-41.5
		1500	0.16	177.7	2.91	64.7	0.12	70.3	0.59	-48.7
		1800	0.14	160.4	2.48	57.1	0.15	68.7	0.61	-55.7
	2000	0.14	153.6	2.26	53.1	0.17	67.5	0.62	-60.4	
	14	100	0.51	-44.8	24.51	142.5	0.01	74.5	0.86	-16.7
300		0.28	-93.9	13.01	108.9	0.03	71.0	0.65	-24.1	
500		0.20	-120.2	8.36	95.3	0.05	72.9	0.59	-26.2	
800		0.17	-147.3	5.40	83.0	0.07	74.0	0.57	-31.8	
1000		0.15	-160.1	4.36	76.6	0.08	74.0	0.57	-36.2	
1200		0.15	-172.1	3.69	71.3	0.10	73.4	0.57	-40.7	
1500		0.14	172.8	2.98	63.9	0.13	71.7	0.58	-48.0	
1800		0.13	155.7	2.52	56.5	0.15	69.8	0.60	-55.1	
2000	0.13	147.1	2.29	52.8	0.17	68.3	0.61	-59.8		
20	100	0.41	-53.2	27.71	137.2	0.01	74.0	0.82	-18.0	
	300	0.22	-105.4	13.38	104.9	0.03	74.1	0.62	-22.9	
	500	0.17	-131.2	8.45	92.6	0.04	75.6	0.58	-24.8	
	800	0.15	-156.4	5.41	81.3	0.07	76.1	0.56	-30.7	
	1000	0.14	-170.4	4.36	75.2	0.09	75.4	0.56	-35.3	
	1200	0.14	177.4	3.68	69.8	0.10	74.5	0.57	-40.0	
	1500	0.14	164.4	2.96	62.5	0.13	72.5	0.58	-47.3	
	1800	0.14	147.5	2.51	55.4	0.15	70.4	0.59	-54.5	
2000	0.13	141.0	2.28	51.5	0.17	68.8	0.60	-59.3		

Common Emitter S-Parameters

$Z_0 = 50 \Omega$

V_{CE}/V	I_C/mA	f/MHz	S_{11}		S_{21}		S_{12}		S_{22}	
			LIN MAG	ANG	LIN MAG	ANG	LIN MAG	ANG	LIN MAG	ANG
				deg		deg		deg		deg
5	30	100	0.30	-67.7	29.72	131.4	0.01	74.3	0.78	-18.4
		300	0.19	-125.3	13.17	101.2	0.03	76.3	0.61	-20.7
		500	0.16	-149.8	8.19	90.0	0.04	78.0	0.58	-22.8
		800	0.16	-171.3	5.23	79.2	0.07	77.8	0.57	-29.0
		1000	0.16	177.6	4.21	73.3	0.08	77.1	0.57	-33.9
		1200	0.16	167.5	3.54	68.2	0.10	76.0	0.58	-38.6
		1500	0.16	156.2	2.85	60.9	0.126	73.9	0.59	-46.1
		1800	0.16	139.1	2.41	53.8	0.15	71.7	0.61	-53.5
		2000	0.16	133.3	2.19	49.9	0.17	70.0	0.62	-58.3
10	2	100	0.92	-16.7	6.23	166.0	0.01	80.6	0.98	-5.7
		300	0.87	-47.6	5.55	142.1	0.03	67.1	0.93	-15.5
		500	0.69	-74.0	4.75	123.3	0.05	58.8	0.87	-22.2
		800	0.53	-106.0	3.67	101.9	0.06	54.1	0.82	-29.5
		1000	0.45	-122.8	3.10	90.9	0.07	54.4	0.80	-33.9
		1200	0.39	-138.0	2.67	82.3	0.08	56.0	0.79	-38.0
		1500	0.33	-158.2	2.19	71.2	0.09	59.8	0.80	-44.3
		1800	0.29	-177.6	1.87	61.2	0.10	63.6	0.81	-50.8
		2000	0.27	172.2	1.70	56.1	0.11	65.5	0.83	-55.3
	5	100	0.80	-24.7	13.17	158.0	0.01	77.5	0.96	-8.8
		300	0.58	-63.9	9.89	126.8	0.03	65.7	0.83	-19.3
		500	0.43	-89.9	7.21	108.5	0.04	63.5	0.76	-23.7
		800	0.30	-117.6	4.94	91.6	0.06	65.9	0.72	-29.2
		1000	0.26	-132.1	4.04	83.4	0.07	67.5	0.71	-33.2
		1200	0.22	-145.9	3.42	76.8	0.08	69.1	0.71	-37.2
		1500	0.19	-163.0	2.77	68.0	0.10	70.2	0.72	-43.6
		1800	0.17	177.9	2.36	59.8	0.12	70.7	0.79	-50.3
		2000	0.15	168.8	2.15	55.6	0.13	70.4	0.75	-54.7
	10	100	0.65	-34.2	20.73	149.1	0.01	74.8	0.92	-11.8
		300	0.39	-77.0	12.60	115.1	0.03	68.7	0.75	-19.8
		500	0.27	-99.8	8.38	99.9	0.04	70.7	0.69	-22.6
		800	0.19	-124.7	5.50	86.3	0.06	73.2	0.67	-27.8
		1000	0.17	-138.1	4.45	79.4	0.07	74.3	0.67	-31.9
		1200	0.15	-151.4	3.76	74.0	0.08	74.2	0.67	-36.2
		1500	0.13	-167.7	3.04	66.4	0.11	74.1	0.68	-42.7
		1800	0.18	174.5	2.58	58.8	0.13	73.1	0.70	-49.5
		2000	0.11	165.6	2.35	54.8	0.14	72.3	0.72	-53.9
	14	100	0.56	-39.9	24.49	144.2	0.01	74.3	0.89	-13.1
		300	0.31	-83.1	13.40	110.5	0.03	71.4	0.72	-19.3
		500	0.21	-104.9	8.66	96.8	0.04	74.1	0.67	-21.6
		800	0.16	-129.3	5.62	84.4	0.06	76.0	0.66	-26.9
		1000	0.14	-142.2	4.55	78.0	0.07	76.3	0.66	-31.0
		1200	0.13	-155.9	3.83	72.7	0.08	76.1	0.66	-35.5
		1500	0.12	-170.8	3.10	65.4	0.10	75.3	0.68	-42.2
		1800	0.11	169.7	2.63	58.1	0.13	74.0	0.70	-49.1
		2000	0.11	162.3	2.39	54.3	0.14	73.0	0.71	-53.5

Typical Characteristics ($T_j = 25^\circ\text{C}$ unless otherwise specified)

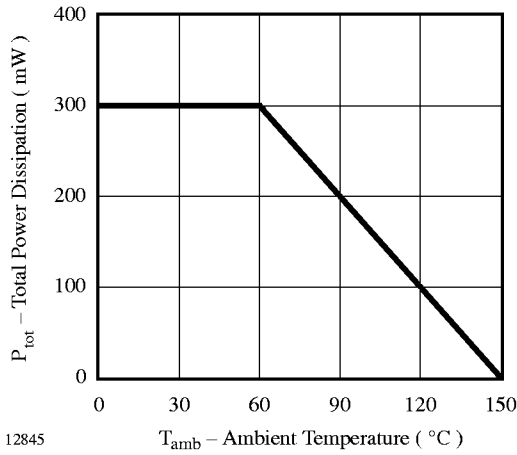

Figure 1.. Total Power Dissipation vs. Ambient Temperature

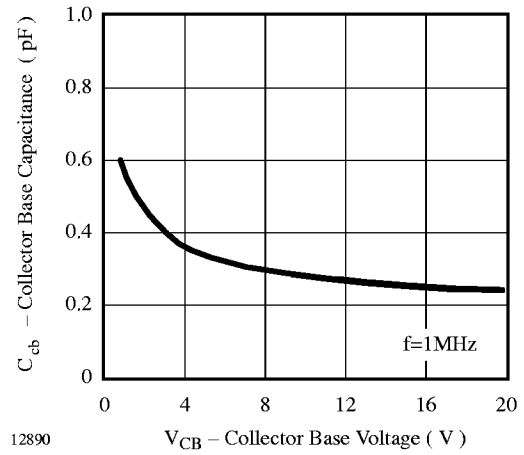

Figure 3.. Collector Base Capacitance vs. Collector Base Voltage

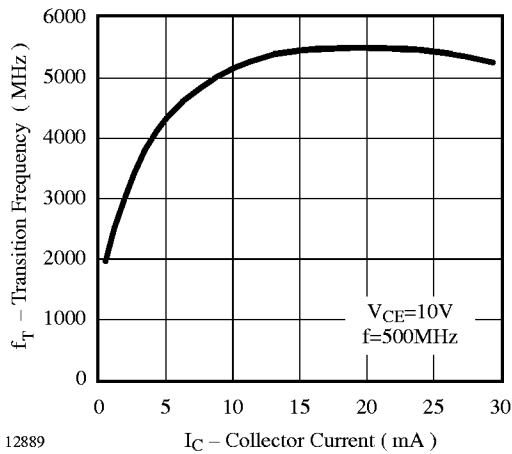

Figure 2.. Transition Frequency vs. Collector Current

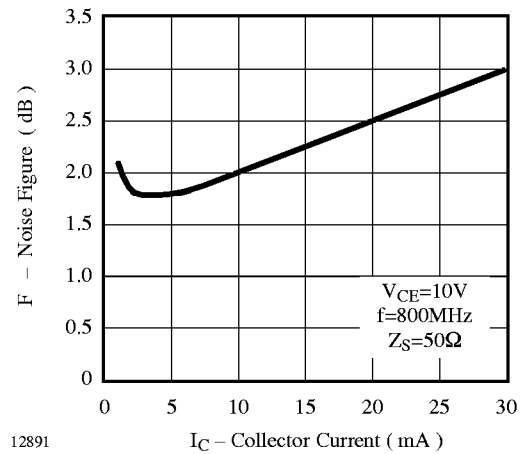

Figure 4.. Noise Figure vs. Collector Current

$V_{CE} = 10 \text{ V}; I_C = 14 \text{ mA}; Z_0 = 50 \Omega$

S_{11}

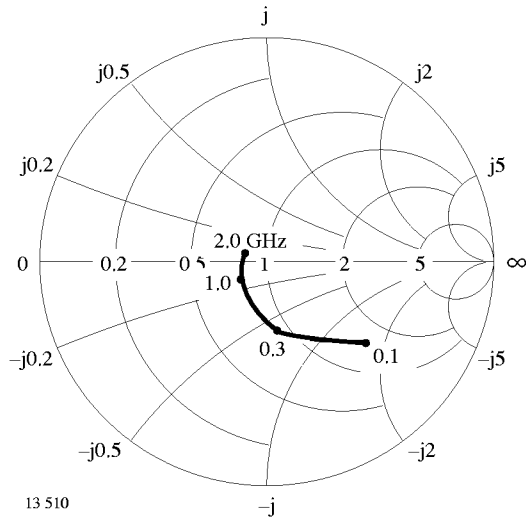

Figure 5. Input reflection coefficient

S_{12}

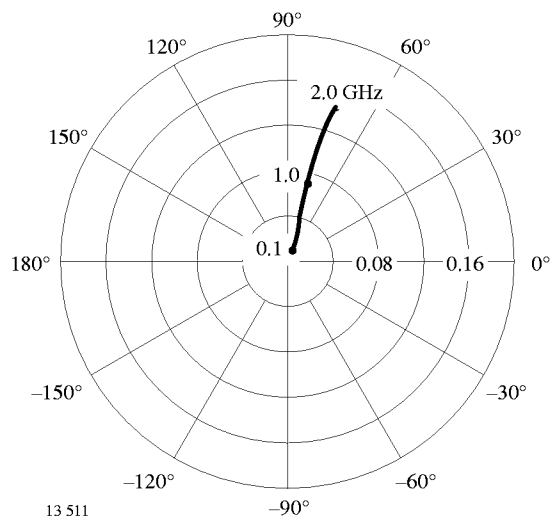

Figure 7. Reverse transmission coefficient

S_{21}

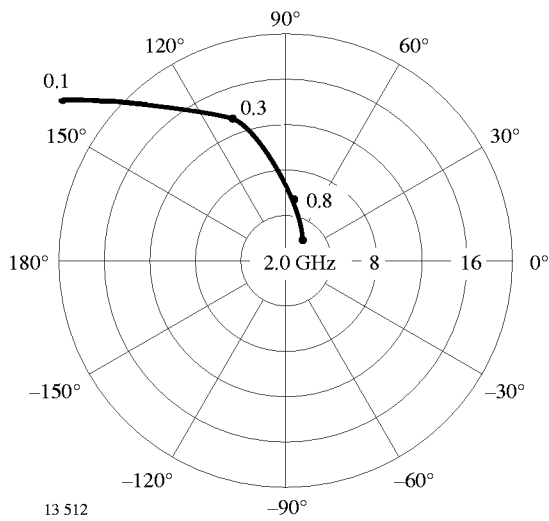

Figure 6. Forward transmission coefficient

S_{22}

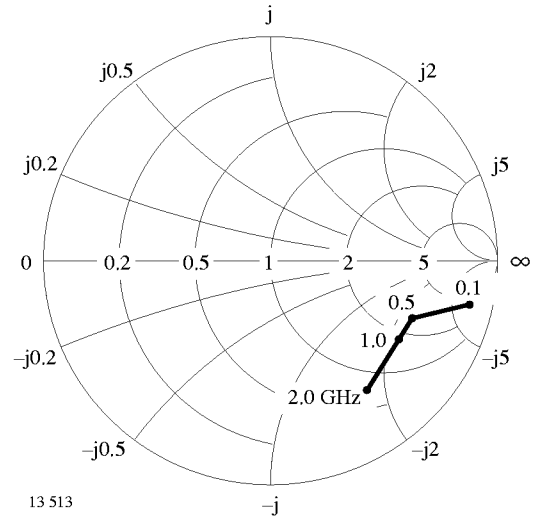
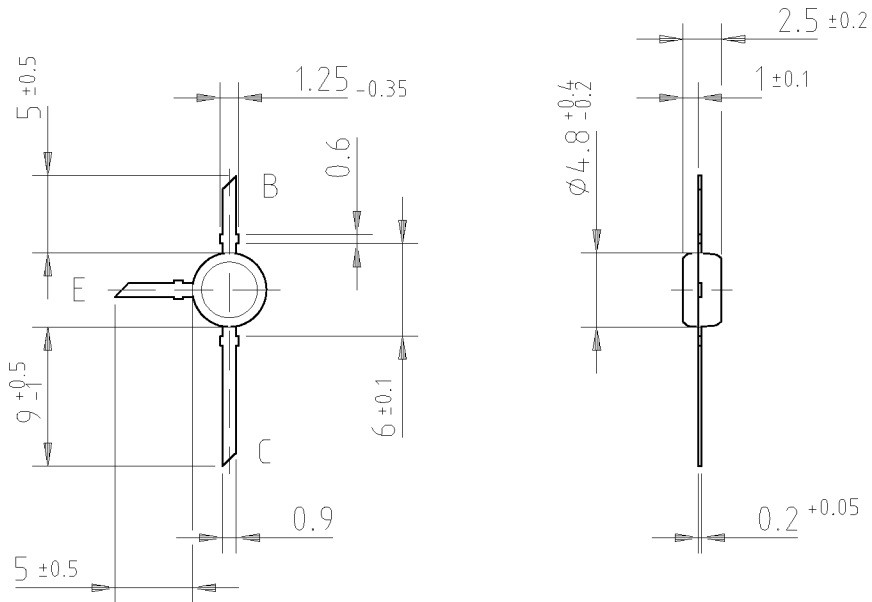
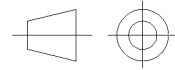

Figure 8. Output reflection coefficient

Dimensions in mm



96 12244



technical drawings
according to DIN
specifications

Ozone Depleting Substances Policy Statement

It is the policy of **TEMIC TELEFUNKEN microelectronic GmbH** to

1. Meet all present and future national and international statutory requirements.
2. Regularly and continuously improve the performance of our products, processes, distribution and operating systems with respect to their impact on the health and safety of our employees and the public, as well as their impact on the environment.

It is particular concern to control or eliminate releases of those substances into the atmosphere which are known as ozone depleting substances (ODSs).

The Montreal Protocol (1987) and its London Amendments (1990) intend to severely restrict the use of ODSs and forbid their use within the next ten years. Various national and international initiatives are pressing for an earlier ban on these substances.

TEMIC TELEFUNKEN microelectronic GmbH semiconductor division has been able to use its policy of continuous improvements to eliminate the use of ODSs listed in the following documents.

1. Annex A, B and list of transitional substances of the Montreal Protocol and the London Amendments respectively
2. Class I and II ozone depleting substances in the Clean Air Act Amendments of 1990 by the Environmental Protection Agency (EPA) in the USA
3. Council Decision 88/540/EEC and 91/690/EEC Annex A, B and C (transitional substances) respectively.

TEMIC can certify that our semiconductors are not manufactured with ozone depleting substances and do not contain such substances.

We reserve the right to make changes to improve technical design and may do so without further notice.

Parameters can vary in different applications. All operating parameters must be validated for each customer application by the customer. Should the buyer use TEMIC products for any unintended or unauthorized application, the buyer shall indemnify TEMIC against all claims, costs, damages, and expenses, arising out of, directly or indirectly, any claim of personal damage, injury or death associated with such unintended or unauthorized use.

TEMIC TELEFUNKEN microelectronic GmbH, P.O.B. 3535, D-74025 Heilbronn, Germany
Telephone: 49 (0)7131 67 2831, Fax number: 49 (0)7131 67 2423