

SPS-4385W-DXXXG**(RoHS Compliant)****8.5 Gbps/ 50 GHz DWDM / 80 km Digital Diagnostic LC SFP+ SINGLE-MODE TRANSCEIVER****FEATURES**

- | Up to 8.5 Gbps Bi-directional Data Links
- | Complaint to SFP+ MSA
- | Compliance with Fibre Channel FC-PI-4 800-SM-LC-L
- | Compliant with 4G and, 2G Fibre Channel
- | **Temperature-stabilized DWDM EML Transmitter**
- | **50 GHz ITU Grid, C Band**
- | **Distance up to 80 km**
- | SFF-8472 Digital Diagnostic Function
- | AC/AC Coupling according to MSA
- | Single +3.3 V Power Supply
- | RoHS 6/6 Compliant
- | 0 to 70°C Operating
- | Class 1 Laser International Safety Standard IEC-60825 Compliant

APPLICATIONS

- | Multi-rate 8x / 4x / 2x Fibre Channel

DESCRIPTION

The SPS-4385W-DXXXG series single mode transceiver is small form factor pluggable module for bi-directional serial optical data communications such as 8x/4x/2x Fibre Channel.

It is with the SFP 20-pin connector to allow hot plug capability. Digital diagnostic functions are available via an I²C. This module is designed for single mode fiber and operates at a nominal wavelength of 50GHz ITU Grid, C Band DWDM wavelength. A guaranteed minimum optical link budget of 23 dB is offered. The transmitter section consists of a temperature-stabilized DWDM electrical-modulated laser (EML), driver and signal conditioner. The receiver section uses an integrated InGaAs detector preamplifier (IDP) mounted in an optical header and a limiting post-amplifier IC.

LASER SAFETY

This single mode transceiver is a Class 1 laser product. It complies with IEC-60825 and FDA 21 CFR 1040.10 and 1040.11. The transceiver must be operated within the specified temperature and voltage limits. The optical ports of the module shall be terminated with an optical connector or with a dust plug.

ORDER INFORMATION

P/No.	Bit Rate (Gb/s)	FC-PI	Power Budget (dB)	Spacing (GHz)	Wavelength (nm)	Package	Temp. (°C)	RoHS Compliant
SPS-4385W-DXXXG	8 / 4 / 2	FC-PI-4	> 23	50	DWDM*	SFP+ with DMI	0 to 70	Yes

*: XXX: 50GHz ITU Grid wavelength (Please see below)

Channel #	Product code	Frequency (THz)	Center Wavelength (nm)	Label
200	SPS-4385W-D200G	192.00	1561.42	200
205	SPS-4385W-D205G	192.05	1561.01	205
210	SPS-4385W-D210G	192.10	1560.61	210
215	SPS-4385W-D215G	192.15	1560.20	215
220	SPS-4385W-D220G	192.20	1559.79	220
225	SPS-4385W-D225G	192.25	1559.39	225
230	SPS-4385W-D230G	192.30	1558.98	230
235	SPS-4385W-D235G	192.35	1558.58	235
240	SPS-4385W-D240G	192.40	1558.17	240
245	SPS-4385W-D245G	192.45	1557.77	245
250	SPS-4385W-D250G	192.50	1557.36	250
255	SPS-4385W-D255G	192.55	1556.96	255
260	SPS-4385W-D260G	192.60	1556.55	260
265	SPS-4385W-D265G	192.65	1556.15	265
270	SPS-4385W-D270G	192.70	1555.75	270
275	SPS-4385W-D275G	192.75	1555.34	275
280	SPS-4385W-D280G	192.80	1554.94	280
285	SPS-4385W-D285G	192.85	1554.54	285
290	SPS-4385W-D290G	192.90	1554.13	290
295	SPS-4385W-D295G	192.95	1553.73	295
300	SPS-4385W-D300G	193.00	1553.33	300
305	SPS-4385W-D305G	193.05	1552.93	305
310	SPS-4385W-D310G	193.10	1552.52	310
315	SPS-4385W-D315G	193.15	1552.12	315
320	SPS-4385W-D320G	193.20	1551.72	320
325	SPS-4385W-D325G	193.25	1551.32	325
330	SPS-4385W-D330G	193.30	1550.92	330
335	SPS-4385W-D335G	193.35	1550.52	335
340	SPS-4385W-D340G	193.40	1550.12	340
345	SPS-4385W-D345G	193.45	1549.72	345
350	SPS-4385W-D350G	193.50	1549.32	350
355	SPS-4385W-D355G	193.55	1548.91	355
360	SPS-4385W-D360G	193.60	1548.51	360
365	SPS-4385W-D365G	193.65	1548.11	365
370	SPS-4385W-D370G	193.70	1547.72	370
375	SPS-4385W-D375G	193.75	1547.32	375
380	SPS-4385W-D380G	193.80	1546.92	380
385	SPS-4385W-D385G	193.85	1546.52	385
390	SPS-4385W-D390G	193.90	1546.12	390
395	SPS-4385W-D395G	193.95	1545.72	395
400	SPS-4385W-D400G	194.00	1545.32	400
405	SPS-4385W-D405G	194.05	1544.92	405
410	SPS-4385W-D410G	194.10	1544.53	410
415	SPS-4385W-D415G	194.15	1544.13	415
420	SPS-4385W-D420G	194.20	1543.73	420
425	SPS-4385W-D425G	194.25	1543.33	425
430	SPS-4385W-D430G	194.30	1542.94	430
435	SPS-4385W-D435G	194.35	1542.54	435
440	SPS-4385W-D440G	194.40	1542.14	440
445	SPS-4385W-D445G	194.45	1541.75	445

Channel #	Product code	Frequency (THz)	Center Wavelength (nm)	Label
450	SPS-4385W-D450G	194.50	1541.35	450
455	SPS-4385W-D455G	194.55	1540.95	455
460	SPS-4385W-D460G	194.60	1540.56	460
465	SPS-4385W-D465G	194.65	1540.16	465
470	SPS-4385W-D470G	194.70	1539.77	470
475	SPS-4385W-D475G	194.75	1539.37	475
480	SPS-4385W-D480G	194.80	1538.98	480
485	SPS-4385W-D485G	194.85	1538.58	485
490	SPS-4385W-D490G	194.90	1538.19	490
495	SPS-4385W-D495G	194.95	1537.79	495
500	SPS-4385W-D500G	195.00	1537.40	500
505	SPS-4385W-D505G	195.05	1537.00	505
510	SPS-4385W-D510G	195.10	1536.61	510
515	SPS-4385W-D515G	195.15	1536.22	515
520	SPS-4385W-D520G	195.20	1535.82	520
525	SPS-4385W-D525G	195.25	1535.43	525
530	SPS-4385W-D530G	195.30	1535.04	530
535	SPS-4385W-D535G	195.35	1534.64	535
540	SPS-4385W-D540G	195.40	1534.25	540
545	SPS-4385W-D545G	195.45	1533.86	545
550	SPS-4385W-D550G	195.50	1533.47	550
555	SPS-4385W-D555G	195.55	1533.07	555
560	SPS-4385W-D560G	195.60	1532.68	560
565	SPS-4385W-D565G	195.65	1532.29	565
570	SPS-4385W-D570G	195.70	1531.90	570
575	SPS-4385W-D575G	195.75	1531.51	575
580	SPS-4385W-D580G	195.80	1531.12	580
585	SPS-4385W-D585G	195.85	1530.72	585
590	SPS-4385W-D590G	195.90	1530.33	590
595	SPS-4385W-D595G	195.95	1529.94	595
600	SPS-4385W-D600G	196.00	1529.55	600

Absolute Maximum Ratings					
Parameter	Symbol	Min	Max	Units	Notes
Storage Temperature	Tstg	-40	85	°C	
Operating Case Temperature	Topr	0	70	°C	
Power Supply Voltage	Vcc	-0.5	3.6	V	
Receiver Input for Damage	Mip	-3		dBm	Average Power

Recommended Operating Conditions					
Parameter	Symbol	Min	Typ	Max	Units / Notes
Power Supply Voltage	Vcc	3.13	3.3	3.47	V
Operating Case Temperature	Topr	0		70	°C
Power Supply Current	I _{CC(TX+RX)}		350	500	mA
Data Rate		2.125	8.5		Gb/s

Transmitter Optical Specifications (0°C < Topr < 70°C, 3.13V < Vcc < 3.47V)						
Parameter	Symbol	Min	Typ	Max	Units	Notes
Average Launch Power	P _{O, AVG}	-1		3	dBm	1
Extinction Ratio	ER	8.2			dB	
Center Wavelength Spacing			50		GHz	
Transmitter Center Wavelength -- over life time	λ _c	X-60	X	X+60	pm	2
Output Spectrum Width	Δλ	---		1	nm	-20 dB width
Side Mode Suppression Ratio	SMSR	30			dB	
Relative Intensity Noise	RIN			-130	dB/Hz	
Transmitter Dispersion Penalty @ -500 to 1600 ps/nm	TDP			3	dB	
Average Launch Power of OFF Transmitter				-30	dBm	

1. Output power is power coupled into a 9/125 μm single-mode fiber.
2. X = specified ITU Grid wavelength.

Receiver Optical Specifications (0°C < Topr < 70°C, 3.13V < Vcc < 3.47V)						
Parameter	Symbol	Min	Typ	Max	Units	Notes
Sensitivity				-24	dBm	3
Receiver Overload	P _{MAX}	-7	---		dBm	
LOS -- Deasserted	LOS _D	---	---	-27	dBm	Transition: low to high
LOS -- Asserted	LOS _A	-35	---	---	dBm	Transition: high to low
Wavelength of Operation	λ _c	1480		1580	nm	

3. Measured with average power; BER < 10⁻¹² and PRBS 2⁷-1.

Electrical Characteristics						
Parameter	Symbol	Min	Typ	Max	Units	Notes
High-Speed Signal (CML) Interface Specification						
Input Data Rate		2.125	8.5		Gb/s	
Differential Input Impedance	R _{in}		100		Ω	
Differential Data Input Amplitude		150		1200	mVpp	Internally AC coupled
Output Data Rate		2.125	8.5		Gb/s	
Differential Output Impedance	R _{out}		100		Ω	
Differential Data Output Amplitude		350	600	700	mVpp	Internally AC coupled
Low-Speed Signal (LVTTTL) Interface Specification						
Input High Voltage		2.0		Vcc+0.3	V	

Input Low Voltage		GND		0.8	V	
Output High Voltage		2.4		V _{cc}	V	
Output Low Voltage		GND		0.5	V	

CONNECTION DIAGRAM

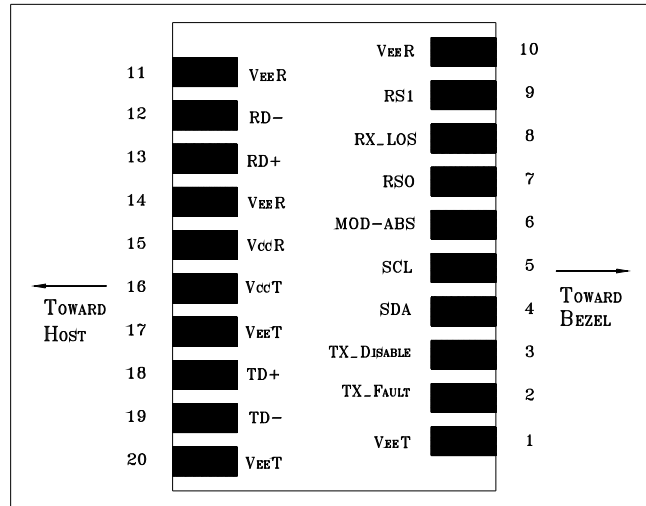

PIN	Signal Name	Description	PIN	Signal Name	Description
1	V _{EE} T	Transmitter Signal Ground	11	V _{EE} R	Receiver Signal Ground
2	TX_Fault	Transmitter Fault Indication. Logic "1" Output = Laser Fault. Logic "0" Output = Normal Operation	12	RD-	Inverse Receiver Data Out
3	TX_Disable	Logic "1" Input (or no connection) = Laser off, Logic "0" = Laser on.	13	RD+	Receiver Data Out
4	SDA	Modulation Definition 2 – Two wires serial ID Interface	14	V _{EE} R	Receiver Signal Ground
5	SDL	Modulation Definition 1 – Two wires serial ID Interface	15	V _{cc} R	Receiver Power – 3.3V±5%
6	MOD-ABS	Modulation Definition 0 – Ground in Module	16	V _{cc} T	Transmitter Power – 3.3V±5%
7	RS0	RX Rate Select (LVTTTL). This pin has an internal 30k pulldown to ground. A signal on this pin will not affect module performance.	17	V _{EE} T	Transmitter Signal Ground
8	RX_LOS	Loss of Signal Out (OC).	18	TD+	Transmitter Data In
9	RS1	TX Rate Select (LVTTTL). This pin has an internal 30k pulldown to ground. A signal on this pin will not affect module performance.	19	TD-	Inverse Transmitter Data In
10	V _{EE} R	Receiver Signal Ground	20	V _{EE} T	Transmitter Signal Ground

MODULE DEFINITION

Module Definition	PIN 4	PIN 5	PIN 6	Interpretation by Host
4	SDA	SCL	MOD-ABS	Serial module definition protocol

Module Definition 4 specifies a serial definition protocol. For this definition, upon power up, SDA and SDL appear as no connector (NC) and MOD-ABS is TTL LOW. When the host system detects this condition, it activates the serial protocol. The protocol uses the 2-wire serial CMOS E²PROM protocol of the ATMEL AT24C01A/02/04 family of components.

RECOMMENDED CIRCUIT SCHEMATIC

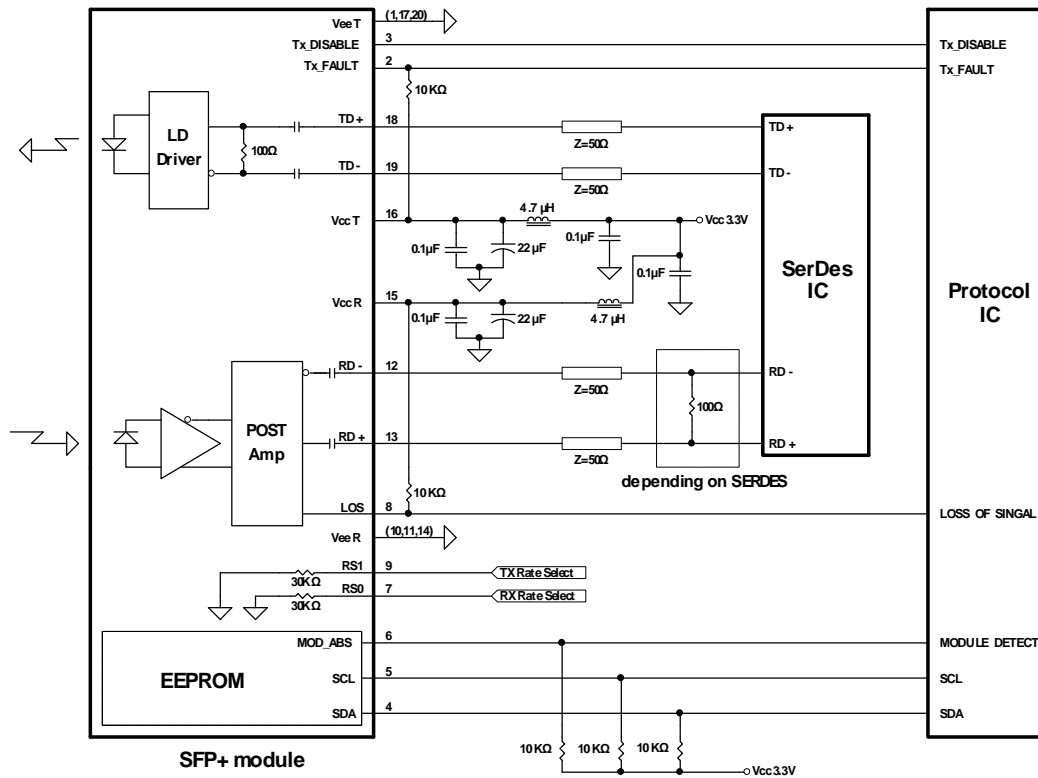

PACKAGE DIAGRAM

Units in mm

Top View

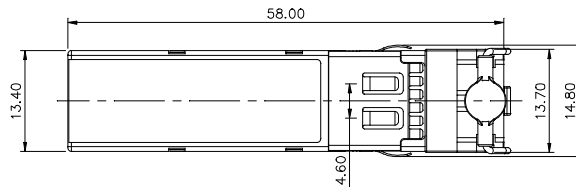

Front View

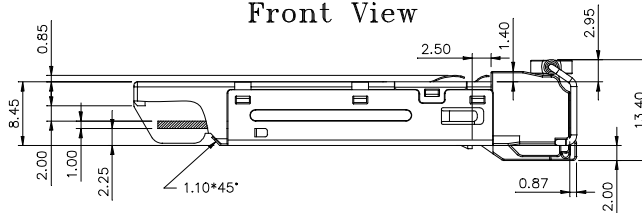

LATCH COLOR
White

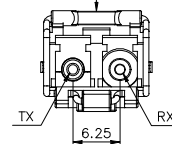

Side View

Bottom View

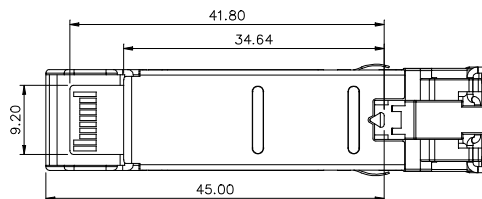

REVISION HISTORY

Version	Subject	Release Date
1.0	Initial datasheet	2011/7/1
2.0	Update the TX center wavelength to +/- 60 pm	2012/8/1

Note: Specifications subject to change without notice.