

## 256 Kbit (32 Kbit x 8) ZEROPOWER® SRAM

### Features

- Integrated, ultra low power SRAM, power-fail control circuit, and battery
- READ cycle time equals WRITE cycle time
- Automatic power-fail chip deselect and WRITE protection
- WRITE protect voltages: ( $V_{PFD}$  = Power-fail deselect voltage)
  - M48Z35:  $V_{CC} = 4.75$  to  $5.5$  V  
 $4.5$  V  $\leq V_{PFD} \leq 4.75$  V
  - M48Z35Y:  $4.5$  to  $5.5$  V  
 $4.2$  V  $\leq V_{PFD} \leq 4.5$  V
- Self-contained battery in the CAPHAT™ DIP package
- Packaging includes a 28-lead SOIC and SNAPHAT® top (to be ordered separately)
- Pin and function compatible with JEDEC standard 32 K x 8 SRAMs
- SOIC package provides direct connection for a SNAPHAT® top which contains the battery
- RoHS compliant
  - Lead-free second level interconnect

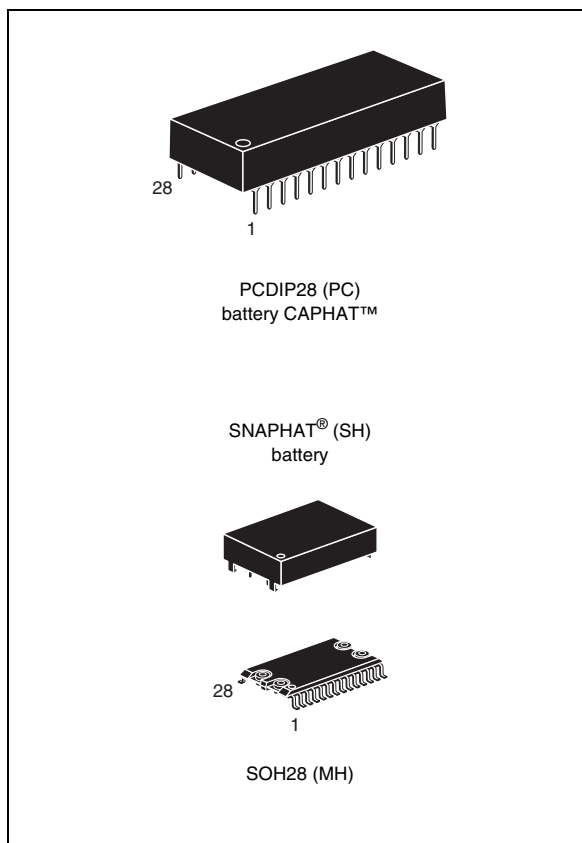

# Contents

<b>1</b>	<b>Description</b> .....	<b>5</b>
<b>2</b>	<b>Operating modes</b> .....	<b>8</b>
2.1	READ mode .....	8
2.2	WRITE mode .....	10
2.3	Data retention mode .....	11
2.4	V <sub>CC</sub> noise and negative going transients .....	13
<b>3</b>	<b>Maximum ratings</b> .....	<b>14</b>
<b>4</b>	<b>DC and AC parameters</b> .....	<b>15</b>
<b>5</b>	<b>Package mechanical data</b> .....	<b>17</b>
<b>6</b>	<b>Part numbering</b> .....	<b>21</b>
<b>7</b>	<b>Environmental information</b> .....	<b>22</b>
<b>8</b>	<b>Revision history</b> .....	<b>23</b>

## List of tables

Table 1.	Signal names	6
Table 2.	Operating modes	8
Table 3.	READ mode AC characteristics	9
Table 4.	WRITE mode AC characteristics	11
Table 5.	Power down/up AC characteristics	12
Table 6.	Power down/up trip points DC characteristics	12
Table 7.	Absolute maximum ratings	14
Table 8.	Operating and AC measurement conditions	15
Table 9.	Capacitance	15
Table 10.	DC characteristics	16
Table 11.	PMDIP28 – 28-pin plastic DIP, battery CAPHAT™, pack. mech. data	17
Table 12.	SOH28 – 28-lead plastic small outline, battery SNAPHAT®, pack. mech. data	18
Table 13.	SH – 4-pin SNAPHAT® housing for 48 mAh battery, pack. mech. data	19
Table 14.	SH – 4-pin SNAPHAT® housing for 120 mAh battery, pack. mech. data	20
Table 15.	Ordering information scheme	21
Table 16.	SNAPHAT® battery table	21
Table 17.	Document revision history	23

## List of figures

Figure 1.	Logic diagram . . . . .	5
Figure 2.	DIP connections . . . . .	6
Figure 3.	SOIC connections . . . . .	6
Figure 4.	Block diagram . . . . .	7
Figure 5.	READ mode AC waveforms . . . . .	9
Figure 6.	WRITE enable controlled, WRITE AC waveforms . . . . .	10
Figure 7.	Chip enable controlled, WRITE AC waveforms . . . . .	10
Figure 8.	Power down/up mode AC waveforms . . . . .	12
Figure 9.	Supply voltage protection . . . . .	13
Figure 10.	AC measurement load circuit . . . . .	15
Figure 11.	PCDIP28 – 28-pin plastic DIP, battery CAPHAT™, package outline . . . . .	17
Figure 12.	SOH28 – 28-lead plastic small outline, battery SNAPHAT®, pack. outline. . . . .	18
Figure 13.	SH – 4-pin SNAPHAT® housing for 48 mAh battery, package outline . . . . .	19
Figure 14.	SH – 4-pin SNAPHAT® housing for 120 mAh battery, package outline . . . . .	20
Figure 15.	Recycling symbols . . . . .	22

# 1 Description

The M48Z35/Y ZEROPOWER<sup>®</sup> RAM is a 32 K x 8, non-volatile static RAM that integrates power-fail deselect circuitry and battery control logic on a single die. The monolithic chip is available in two special packages to provide a highly integrated battery-backed memory solution.

The M48Z35/Y is a non-volatile pin and function equivalent to any JEDEC standard 32 K x 8 SRAM. It also easily fits into many ROM, EPROM, and EEPROM sockets, providing the non-volatility of PROMs without any requirement for special WRITE timing or limitations on the number of WRITES that can be performed. The 28-pin 600 mil DIP CAPHAT<sup>™</sup> houses the M48Z35/Y silicon with a long life lithium button cell in a single package.

The 28-pin 330 mil SOIC provides sockets with gold plated contacts at both ends for direct connection to a separate SNAPHAT<sup>®</sup> housing containing the battery. The unique design allows the SNAPHAT battery package to be mounted on top of the SOIC package after the completion of the surface mount process. Insertion of the SNAPHAT housing after reflow prevents potential battery damage due to the high temperatures required for device surface-mounting. The SNAPHAT housing is keyed to prevent reverse insertion.

The SOIC and battery packages are shipped separately in plastic anti-static tubes or in tape & reel form.

For the 28-lead SOIC, the battery package (i.e. SNAPHAT) part number is "M4Z28-BR00SH1."

**Figure 1. Logic diagram**

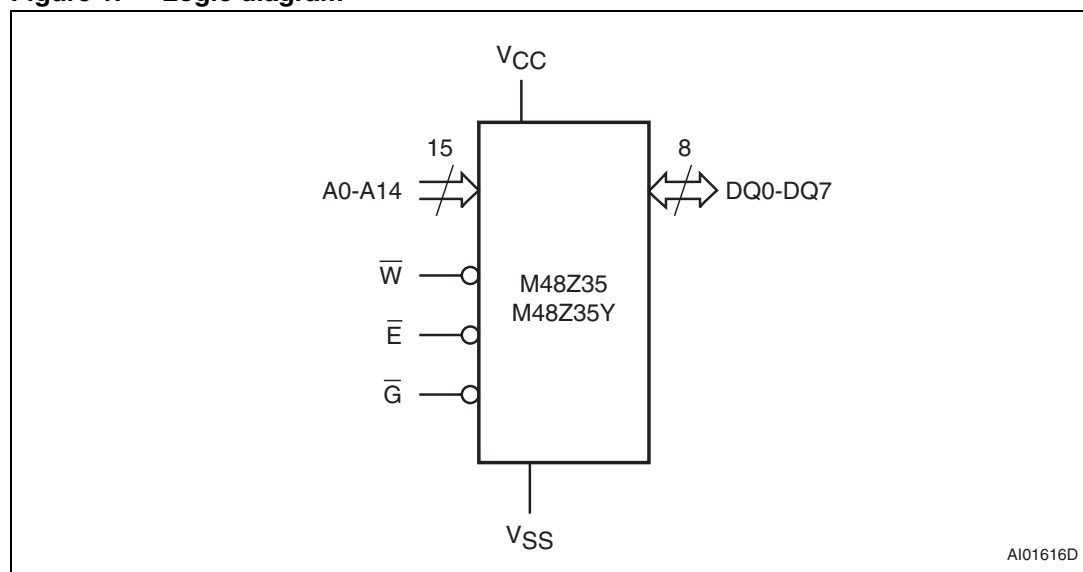

**Table 1. Signal names**

A0-A14	Address inputs
DQ0-DQ7	Data inputs / outputs
$\bar{E}$	Chip enable input
$\bar{G}$	Output enable input
$\bar{W}$	WRITE enable input
V <sub>CC</sub>	Supply voltage
V <sub>SS</sub>	Ground

**Figure 2. DIP connections**

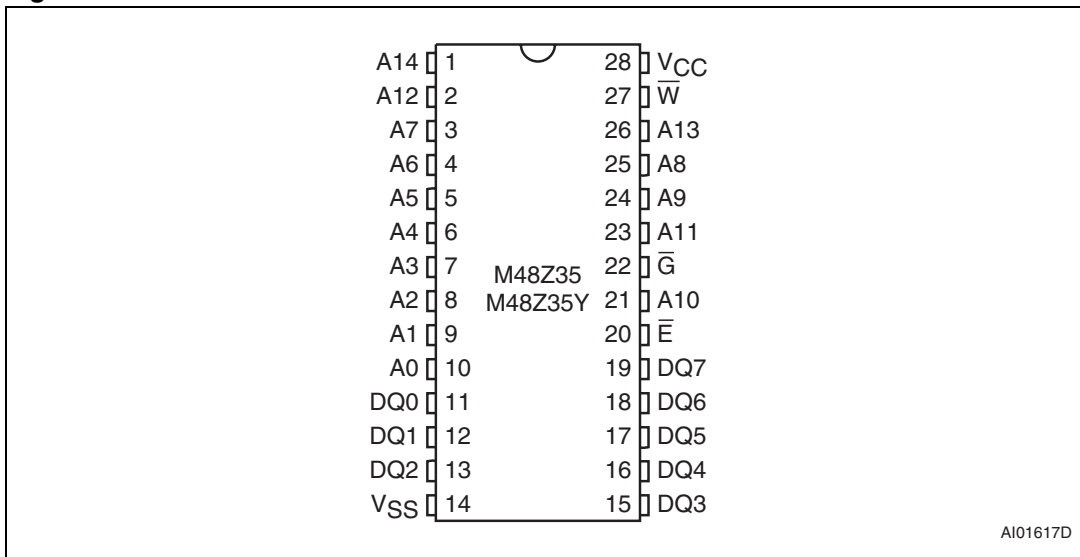

**Figure 3. SOIC connections**

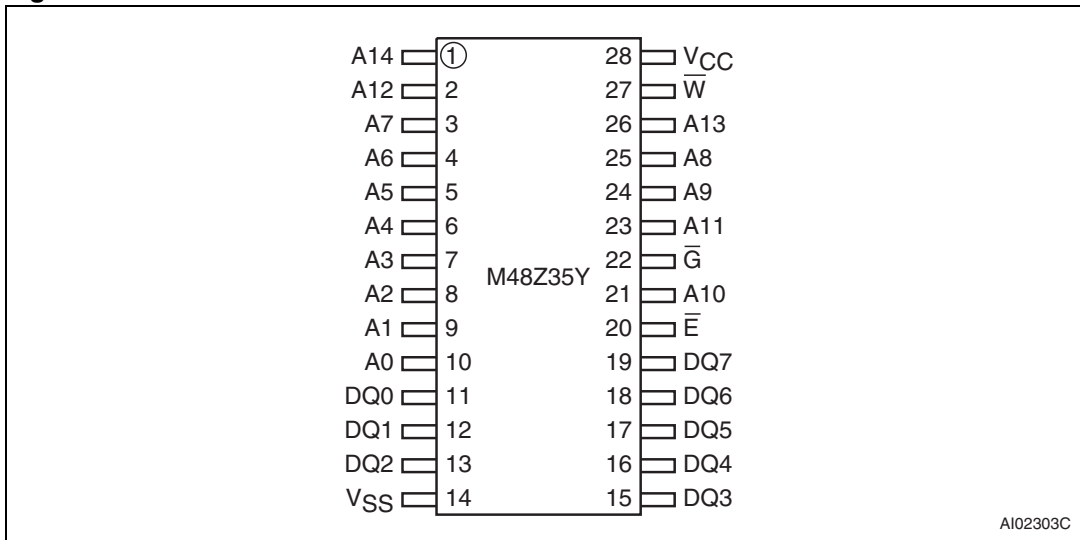
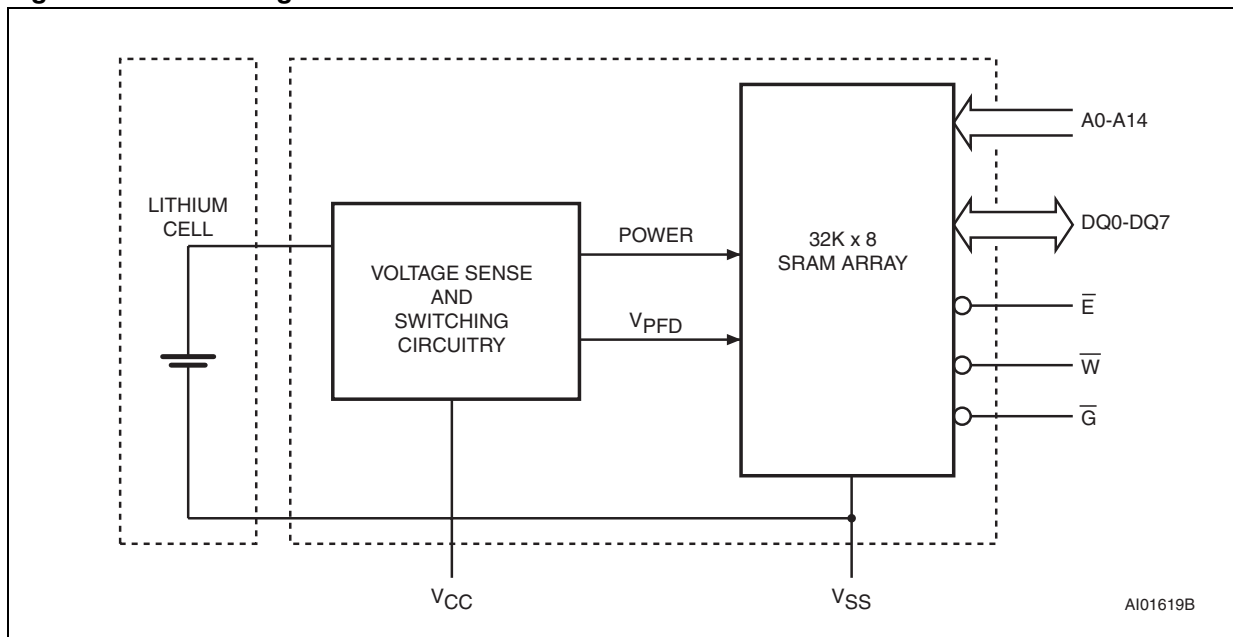

Figure 4. Block diagram



## 2 Operating modes

The M48Z35/Y also has its own power-fail detect circuit. The control circuitry constantly monitors the single 5 V supply for an out of tolerance condition. When  $V_{CC}$  is out of tolerance, the circuit write protects the SRAM, providing a high degree of data security in the midst of unpredictable system operation brought on by low  $V_{CC}$ . As  $V_{CC}$  falls below approximately 3 V, the control circuitry connects the battery which maintains data until valid power returns.

**Table 2. Operating modes**

Mode	$V_{CC}$	$\bar{E}$	$\bar{G}$	$\bar{W}$	DQ0-DQ7	Power
Deselect	4.75 to 5.5 V or 4.5 to 5.5 V	$V_{IH}$	X	X	High Z	Standby
WRITE		$V_{IL}$	X	$V_{IL}$	$D_{IN}$	Active
READ		$V_{IL}$	$V_{IL}$	$V_{IH}$	$D_{OUT}$	Active
READ		$V_{IL}$	$V_{IH}$	$V_{IH}$	High Z	Active
Deselect	$V_{SO}$ to $V_{PFD}$ (min) <sup>(1)</sup>	X	X	X	High Z	CMOS standby
Deselect	$\leq V_{SO}$ <sup>(1)</sup>	X	X	X	High Z	Battery backup mode

1. See [Table 6 on page 12](#) for details.

Note:  $X = V_{IH}$  or  $V_{IL}$ ;  $V_{SO}$  = Battery backup switchover voltage.

### 2.1 READ mode

The M48Z35/Y is in the READ mode whenever  $\bar{W}$  (WRITE enable) is high,  $\bar{E}$  (chip enable) is low. The device architecture allows ripple-through access of data from eight of 264,144 locations in the static storage array. Thus, the unique address specified by the 15 address inputs defines which one of the 32,768 bytes of data is to be accessed. Valid data will be available at the data I/O pins within address access time ( $t_{AVQV}$ ) after the last address input signal is stable, providing that the  $\bar{E}$  and  $\bar{G}$  access times are also satisfied. If the  $\bar{E}$  and  $\bar{G}$  access times are not met, valid data will be available after the latter of the chip enable access time ( $t_{ELQV}$ ) or output enable access time ( $t_{GLQV}$ ).

The state of the eight three-state data I/O signals is controlled by  $\bar{E}$  and  $\bar{G}$ . If the outputs are activated before  $t_{AVQV}$ , the data lines will be driven to an indeterminate state until  $t_{AVQV}$ . If the address inputs are changed while  $\bar{E}$  and  $\bar{G}$  remain active, output data will remain valid for output data hold time ( $t_{AXQX}$ ) but will go indeterminate until the next address access.



Figure 5. READ mode AC waveforms

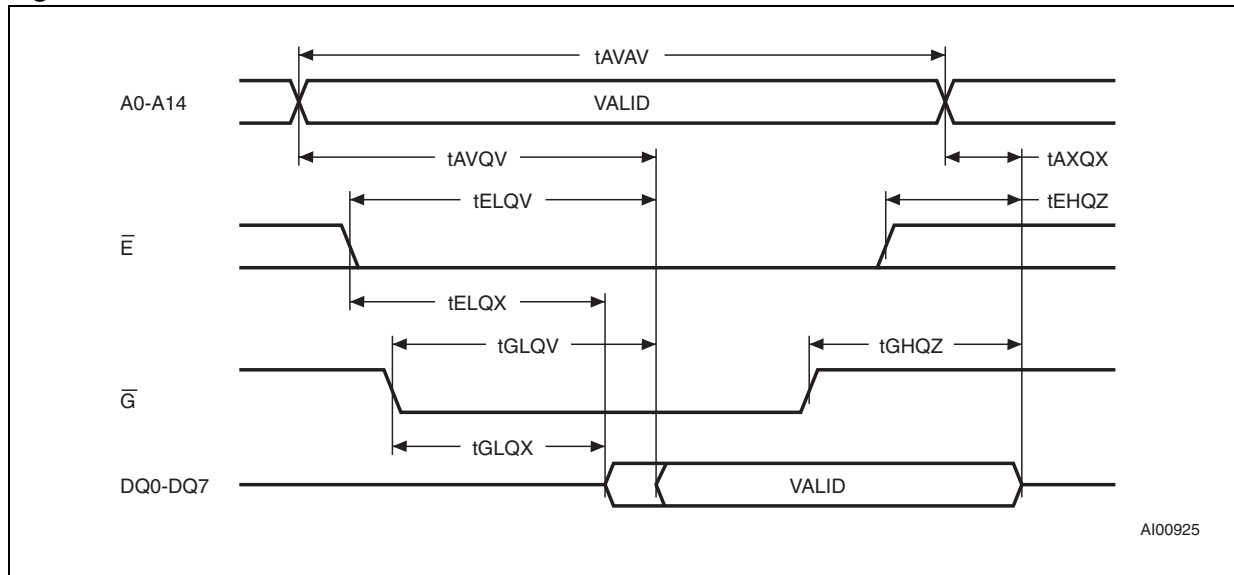

Note: WRITE enable ( $\bar{W}$ ) = High.

Table 3. READ mode AC characteristics

Symbol	Parameter <sup>(1)</sup>	M48Z35/Y		Unit
		-70		
		Min	Max	
$t_{AVAV}$	READ cycle time	70		ns
$t_{AVQV}^{(2)}$	Address valid to output valid		70	ns
$t_{ELQV}^{(2)}$	Chip enable low to output valid		70	ns
$t_{GLQV}^{(2)}$	Output enable low to output valid		35	ns
$t_{ELQX}^{(3)}$	Chip enable low to output transition	5		ns
$t_{GLQX}^{(3)}$	Output enable low to output transition	5		ns
$t_{EHQZ}^{(3)}$	Chip enable high to output Hi-Z		25	ns
$t_{GHQZ}^{(3)}$	Output enable high to output Hi-Z		25	ns
$t_{AXQX}^{(2)}$	Address transition to output transition	10		ns

1. Valid for ambient operating temperature:  $T_A = 0$  to  $70$  °C;  $V_{CC} = 4.75$  to  $5.5$  V or  $4.5$  to  $5.5$  V (except where noted).

2.  $C_L = 100$  pF.

3.  $C_L = 5$  pF.

## 2.2 WRITE mode

The M48Z35/Y is in the WRITE mode whenever  $\overline{W}$  and  $\overline{E}$  are low. The start of a WRITE is referenced from the latter occurring falling edge of  $\overline{W}$  or  $\overline{E}$ . A WRITE is terminated by the earlier rising edge of  $\overline{W}$  or  $\overline{E}$ . The addresses must be held valid throughout the cycle.  $\overline{E}$  or  $\overline{W}$  must return high for a minimum of  $t_{EHAX}$  from chip enable or  $t_{WHAX}$  from WRITE enable prior to the initiation of another READ or WRITE cycle. Data-in must be valid  $t_{DVWH}$  prior to the end of WRITE and remain valid for  $t_{WHDX}$  afterward.  $\overline{G}$  should be kept high during WRITE cycles to avoid bus contention; although, if the output bus has been activated by a low on  $\overline{E}$  and  $\overline{G}$ , a low on  $\overline{W}$  will disable the outputs  $t_{WLQZ}$  after  $\overline{W}$  falls.

Figure 6. WRITE enable controlled, WRITE AC waveforms

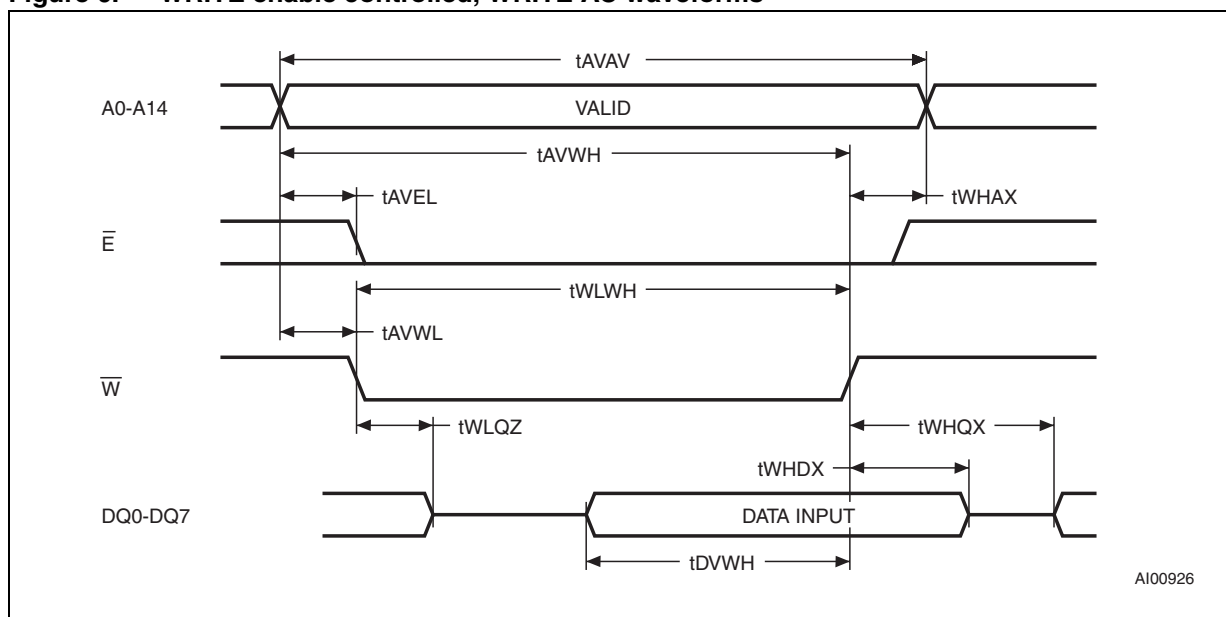

Figure 7. Chip enable controlled, WRITE AC waveforms

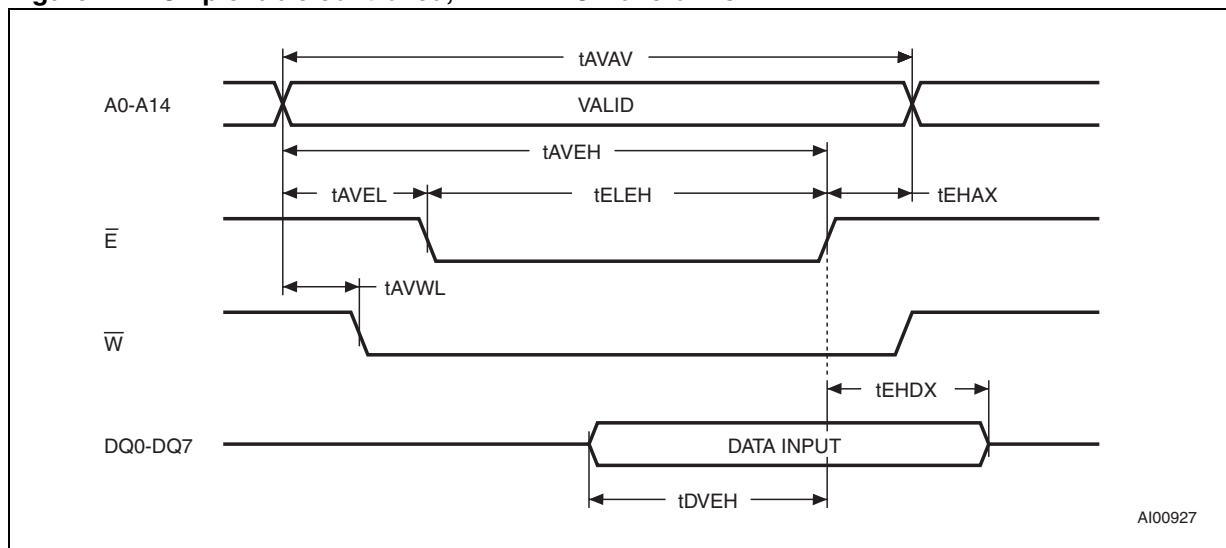

Table 4. WRITE mode AC characteristics

Symbol	Parameter <sup>(1)</sup>	M48Z35/Y		Unit
		-70		
		Min	Max	
$t_{AVAV}$	WRITE cycle time	70		ns
$t_{AVWL}$	Address valid to WRITE enable low	0		ns
$t_{AVEL}$	Address valid to chip enable low	0		ns
$t_{WLWH}$	WRITE enable pulse width	50		ns
$t_{ELEH}$	Chip enable low to chip enable high	55		ns
$t_{WHAX}$	WRITE enable high to address transition	0		ns
$t_{EHAX}$	Chip enable high to address transition	0		ns
$t_{DVWH}$	Input valid to WRITE enable high	30		ns
$t_{DVEH}$	Input valid to chip enable high	30		ns
$t_{WHDX}$	WRITE enable high to input transition	5		ns
$t_{EHDX}$	Chip enable high to input transition	5		ns
$t_{WLQZ}^{(2)(3)}$	WRITE enable low to output Hi-Z		25	ns
$t_{AVWH}$	Address valid to WRITE enable high	60		ns
$t_{AVEH}$	Address valid to chip enable high	60		ns
$t_{WHQX}^{(2)(3)}$	WRITE enable high to output transition	5		ns

1. Valid for ambient operating temperature:  $T_A = 0$  to  $70$  °C;  $V_{CC} = 4.75$  to  $5.5$  V or  $4.5$  to  $5.5$  V (except where noted).

2.  $C_L = 5$  pF (see [Figure 10 on page 15](#)).

3. If  $\bar{E}$  goes low simultaneously with  $\bar{W}$  going low, the outputs remain in the high impedance state.

## 2.3 Data retention mode

With valid  $V_{CC}$  applied, the M48Z35/Y operates as a conventional BYTEWIDE™ static RAM. Should the supply voltage decay, the RAM will automatically power-fail deselect, write protecting itself when  $V_{CC}$  falls within the  $V_{PFD(max)}$ ,  $V_{PFD(min)}$  window. All outputs become high impedance, and all inputs are treated as “don't care.”

*Note:* A power failure during a WRITE cycle may corrupt data at the currently addressed location, but does not jeopardize the rest of the RAM's content. At voltages below  $V_{PFD(min)}$ , the user can be assured the memory will be in a write protected state, provided the  $V_{CC}$  fall time is not less than  $t_F$ . The M48Z35/Y may respond to transient noise spikes on  $V_{CC}$  that reach into the deselect window during the time the device is sampling  $V_{CC}$ . Therefore, decoupling of the power supply lines is recommended.

When  $V_{CC}$  drops below  $V_{SO}$ , the control circuit switches power to the internal battery which preserves data. The internal button cell will maintain data in the M48Z35/Y for an accumulated period of at least 10 years (at 25°C) when  $V_{CC}$  is less than  $V_{SO}$ .

As system power returns and  $V_{CC}$  rises above  $V_{SO}$ , the battery is disconnected, and the power supply is switched to external  $V_{CC}$ . Write protection continues until  $V_{CC}$  reaches  $V_{PFD(min)}$  plus  $t_{REC(min)}$ . Normal RAM operation can resume  $t_{REC}$  after  $V_{CC}$  exceeds  $V_{PFD(max)}$ .

For more information on battery storage life refer to the application note AN1012.

Figure 8. Power down/up mode AC waveforms

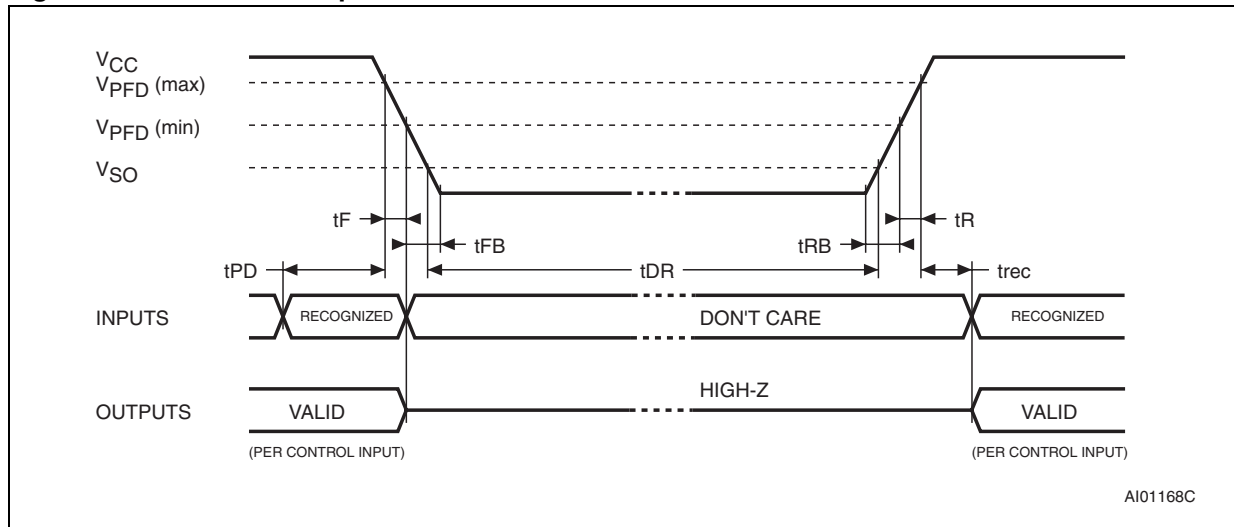

Table 5. Power down/up AC characteristics

Symbol	Parameter <sup>(1)</sup>	Min	Max	Unit
t <sub>PD</sub>	$\bar{E}$ or $\bar{W}$ at V <sub>IH</sub> before power down	0		μs
t <sub>F</sub> <sup>(2)</sup>	V <sub>PFD</sub> (max) to V <sub>PFD</sub> (min) V <sub>CC</sub> fall time	300		μs
t <sub>FB</sub> <sup>(3)</sup>	V <sub>PFD</sub> (min) to V <sub>SS</sub> V <sub>CC</sub> fall time	10		μs
t <sub>R</sub>	V <sub>PFD</sub> (min) to V <sub>PFD</sub> (max) V <sub>CC</sub> rise time	10		μs
t <sub>RB</sub>	V <sub>SS</sub> to V <sub>PFD</sub> (min) V <sub>CC</sub> rise time	1		μs
t <sub>rec</sub>	V <sub>PFD</sub> (max) to inputs recognized	40	200	ms

- Valid for ambient operating temperature: T<sub>A</sub> = 0 to 70 °C; V<sub>CC</sub> = 4.75 to 5.5 V or 4.5 to 5.5 V (except where noted).
- V<sub>PFD</sub> (max) to V<sub>PFD</sub> (min) fall time of less than t<sub>F</sub> may result in deselection/write protection not occurring until 200 μs after V<sub>CC</sub> passes V<sub>PFD</sub> (min).
- V<sub>PFD</sub> (min) to V<sub>SS</sub> fall time of less than t<sub>FB</sub> may cause corruption of RAM data.

Table 6. Power down/up trip points DC characteristics

Symbol	Parameter <sup>(1)</sup>	Min	Typ	Max	Unit	
V <sub>PFD</sub>	Power-fail deselect voltage	M48Z35	4.5	4.6	4.75	V
		M48Z35Y	4.2	4.35	4.5	V
V <sub>SO</sub>	Battery backup switchover voltage	M48Z35/Y	3.0		V	
t <sub>DR</sub> <sup>(2)</sup>	Expected data retention time	10			Years	

- Valid for ambient operating temperature: T<sub>A</sub> = 0 to 70 °C; V<sub>CC</sub> = 4.75 to 5.5V or 4.5 to 5.5V (except where noted).
- At 25 °C, V<sub>CC</sub> = 0 V.

Note: All voltages referenced to V<sub>SS</sub>.

## 2.4 $V_{CC}$ noise and negative going transients

$I_{CC}$  transients, including those produced by output switching, can produce voltage fluctuations, resulting in spikes on the  $V_{CC}$  bus. These transients can be reduced if capacitors are used to store energy which stabilizes the  $V_{CC}$  bus. The energy stored in the bypass capacitors will be released as low going spikes are generated or energy will be absorbed when overshoots occur. A ceramic bypass capacitor value of  $0.1 \mu\text{F}$  (see [Figure 9](#)) is recommended in order to provide the needed filtering.

In addition to transients that are caused by normal SRAM operation, power cycling can generate negative voltage spikes on  $V_{CC}$  that drive it to values below  $V_{SS}$  by as much as one volt. These negative spikes can cause data corruption in the SRAM while in battery backup mode. To protect from these voltage spikes, ST recommends connecting a Schottky diode from  $V_{CC}$  to  $V_{SS}$  (cathode connected to  $V_{CC}$ , anode to  $V_{SS}$ ). (Schottky diode 1N5817 is recommended for through hole and MBR5120T3 is recommended for surface mount).

**Figure 9. Supply voltage protection**

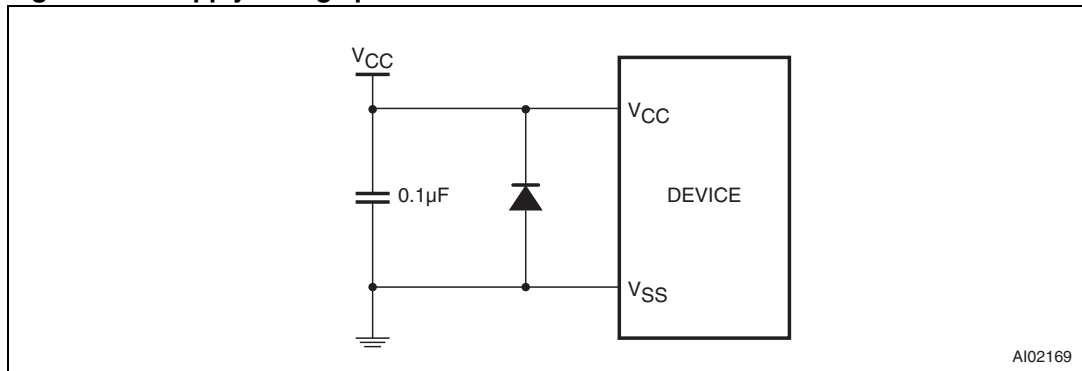

### 3 Maximum ratings

Stressing the device above the rating listed in the absolute maximum ratings table may cause permanent damage to the device. These are stress ratings only and operation of the device at these or any other conditions above those indicated in the operating sections of this specification is not implied. Exposure to absolute maximum rating conditions for extended periods may affect device reliability.

**Table 7. Absolute maximum ratings**

Symbol	Parameter	Value	Unit	
$T_A$	Ambient operating temperature	0 to 70	°C	
$T_{STG}$	Storage temperature ( $V_{CC}$ off, oscillator off)	SNAPHAT® top	-40 to 85	°C
		CAPHAT® DIP	-40 to 85	°C
		SOH28	-55 to 125	°C
$T_{SLD}^{(1)(2)}$	Lead solder temperature for 10 seconds	260	°C	
$V_{IO}$	Input or output voltages	-0.3 to 7.0	V	
$V_{CC}$	Supply voltage	-0.3 to 7.0	V	
$I_O$	Output current	20	mA	
$P_D$	Power dissipation	1	W	

1. For DIP package, soldering temperature of the IC leads is to not exceed 260 °C for 10 seconds. In order to protect the lithium battery, preheat temperatures must be limited such that the battery temperature does not exceed +85 °C. Furthermore, the devices shall not be exposed to IR reflow.
2. For SOH28 package, lead-free (Pb-free) lead finish: reflow at peak temperature of 260 °C (the time above 255 °C must not exceed 30 seconds).

**Caution:** *Negative undershoots below -0.3 V are not allowed on any pin while in the battery backup mode.*

**Caution:** *Do NOT wave solder SOIC to avoid damaging SNAPHAT® sockets.*

## 4 DC and AC parameters

This section summarizes the operating and measurement conditions, as well as the DC and AC characteristics of the device. The parameters in the following DC and AC characteristic tables are derived from tests performed under the measurement conditions listed in [Table 8: Operating and AC measurement conditions](#). Designers should check that the operating conditions in their projects match the measurement conditions when using the quoted parameters.

**Table 8. Operating and AC measurement conditions**

Parameter	M48Z35	M48Z35Y	Unit
Supply voltage ( $V_{CC}$ )	4.75 to 5.5	4.5 to 5.5	V
Ambient operating temperature ( $T_A$ )	0 to 70	0 to 70	°C
Load capacitance ( $C_L$ )	100	100	pF
Input rise and fall times	$\leq 5$	$\leq 5$	ns
Input pulse voltages	0 to 3	0 to 3	V
Input and output timing ref. voltages	1.5	1.5	V

*Note:* Output Hi-Z is defined as the point where data is no longer driven.

**Figure 10. AC measurement load circuit**

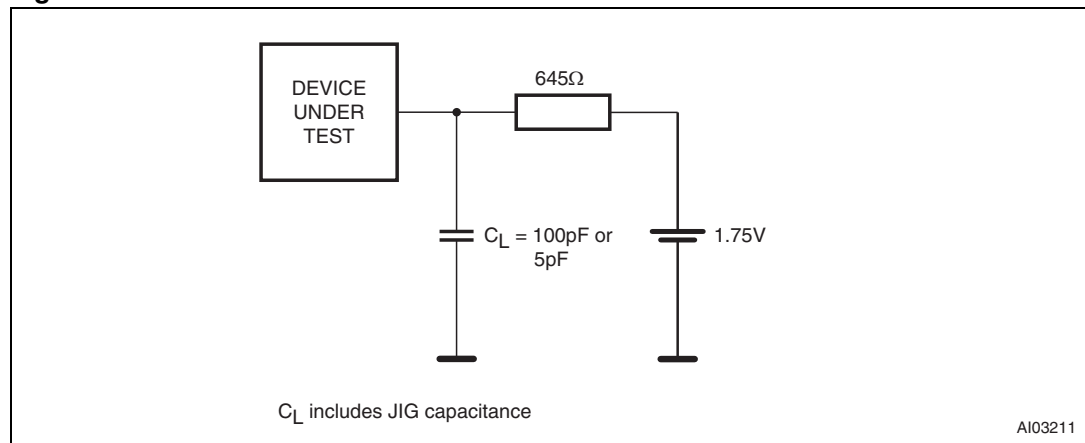

**Table 9. Capacitance**

Symbol	Parameter <sup>(1)(2)</sup>	Min	Max	Unit
$C_{IN}$	Input capacitance	-	10	pF
$C_{IO}^{(3)}$	Input / output capacitance	-	10	pF

1. Effective capacitance measured with power supply at 5 V. Sampled only, not 100% tested.
2. Outputs deselected.
3. At 25 °C.

Table 10. DC characteristics

Symbol	Parameter	Test condition <sup>(1)</sup>	Min	Max	Unit
$I_{LI}^{(2)}$	Input leakage current	$0\text{ V} \leq V_{IN} \leq V_{CC}$		$\pm 1$	$\mu\text{A}$
$I_{LO}^{(2)}$	Output leakage current	$0\text{ V} \leq V_{OUT} \leq V_{CC}$		$\pm 5$	$\mu\text{A}$
$I_{CC}$	Supply current	Outputs open		50	mA
$I_{CC1}$	Supply current (standby) TTL	$\bar{E} = V_{IH}$		3	mA
$I_{CC2}$	Supply current (standby) CMOS	$\bar{E} = V_{CC} - 0.2\text{ V}$		3	mA
$V_{IL}$	Input low voltage		-0.3	0.8	V
$V_{IH}$	Input high voltage		2.2	$V_{CC} + 0.3$	V
$V_{OL}$	Output low voltage	$I_{OL} = 2.1\text{ mA}$		0.4	V
$V_{OH}$	Output high voltage	$I_{OH} = -1\text{ mA}$	2.4		V

1. Valid for ambient operating temperature:  $T_A = 0$  to  $70\text{ }^\circ\text{C}$ ;  $V_{CC} = 4.75$  to  $5.5\text{ V}$  or  $4.5$  to  $5.5\text{ V}$  (except where noted).
2. Outputs deselected.



## 5 Package mechanical data

In order to meet environmental requirements, ST offers these devices in different grades of ECOPACK<sup>®</sup> packages, depending on their level of environmental compliance. ECOPACK<sup>®</sup> specifications, grade definitions and product status are available at: [www.st.com](http://www.st.com). ECOPACK<sup>®</sup> is an ST trademark.

**Figure 11. PCDIP28 – 28-pin plastic DIP, battery CAPHAT<sup>™</sup>, package outline**

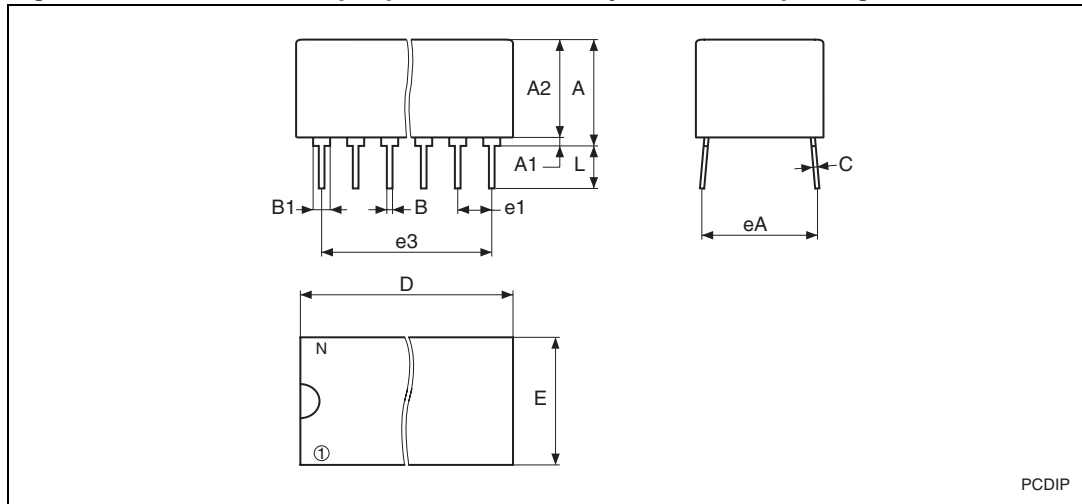

Note: Drawing is not to scale.

**Table 11. PMDIP28 – 28-pin plastic DIP, battery CAPHAT<sup>™</sup>, pack. mech. data**

Symbol	mm			inches		
	Typ	Min	Max	Typ	Min	Max
A		8.89	9.65		0.350	0.380
A1		0.38	0.76		0.015	0.030
A2		8.38	8.89		0.330	0.350
B		0.38	0.53		0.015	0.021
B1		1.14	1.78		0.045	0.070
C		0.20	0.31		0.008	0.012
D		39.37	39.88		1.550	1.570
E		17.83	18.34		0.702	0.722
e1		2.29	2.79		0.090	0.110
e3	33.02			1.3		
eA		15.24	16.00		0.600	0.630
L		3.05	3.81		0.120	0.150
N		28			28	

Figure 12. SOH28 – 28-lead plastic small outline, battery SNAPHAT®, pack. outline

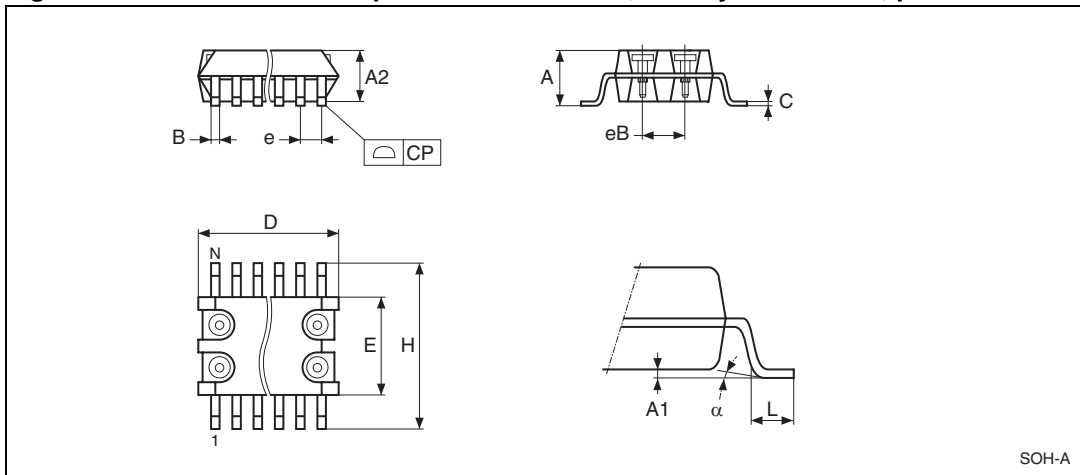

Note: Drawing is not to scale.

Table 12. SOH28 – 28-lead plastic small outline, battery SNAPHAT®, pack. mech. data

Symbol	mm			inches		
	Typ	Min	Max	Typ	Min	Max
A			3.05			0.120
A1		0.05	0.36		0.002	0.014
A2		2.34	2.69		0.092	0.106
B		0.36	0.51		0.014	0.020
C		0.15	0.32		0.006	0.012
D		17.71	18.49		0.697	0.728
E		8.23	8.89		0.324	0.350
e	1.27	–	–	0.050	–	–
eB		3.20	3.61		0.126	0.142
H		11.51	12.70		0.453	0.500
L		0.41	1.27		0.016	0.050
a		0°	8°		0°	8°
N		28			28	
CP			0.10			0.004

Figure 13. SH – 4-pin SNAPHAT® housing for 48 mAh battery, package outline

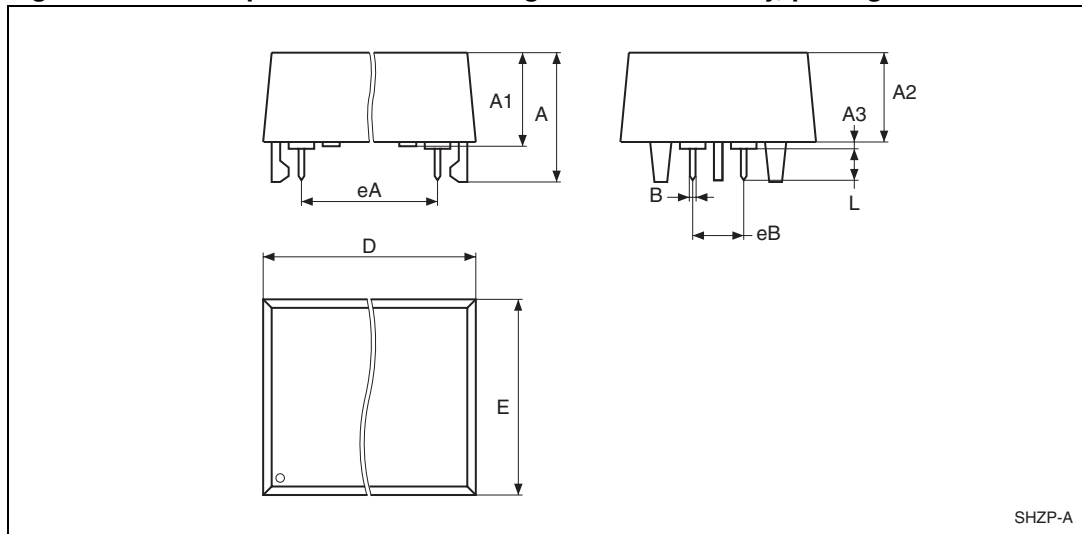

Note: Drawing is not to scale.

Table 13. SH – 4-pin SNAPHAT® housing for 48 mAh battery, pack. mech. data

Symbol	mm			inches		
	Typ	Min	Max	Typ	Min	Max
A			9.78			0.385
A1		6.73	7.24		0.265	0.285
A2		6.48	6.99		0.255	0.275
A3			0.38			0.015
B		0.46	0.56		0.018	0.022
D		21.21	21.84		0.835	0.860
E		14.22	14.99		0.560	0.590
eA		15.55	15.95		0.612	0.628
eB		3.20	3.61		0.126	0.142
L		2.03	2.29		0.080	0.090

Figure 14. SH – 4-pin SNAPHAT® housing for 120 mAh battery, package outline

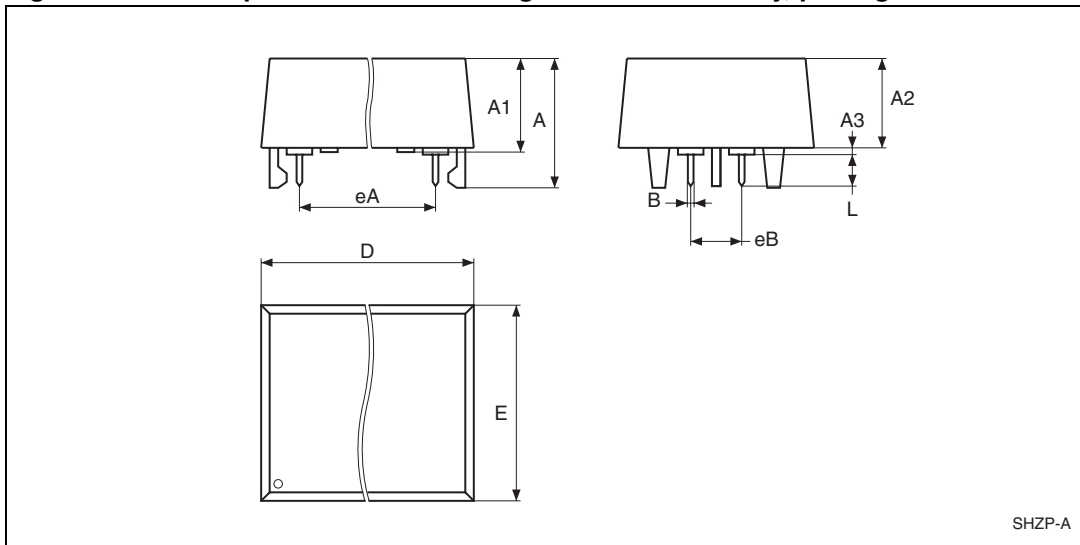

SHZP-A

Note: Drawing is not to scale.

Table 14. SH – 4-pin SNAPHAT® housing for 120 mAh battery, pack. mech. data

Symb	mm			inches		
	Typ	Min	Max	Typ	Min	Max
A			10.54			0.415
A1		8.00	8.51		0.315	0.335
A2		7.24	8.00		0.285	0.315
A3			0.38			0.015
B		0.46	0.56		0.018	0.022
D		21.21	21.84		0.835	0.860
E		17.27	18.03		0.680	0.710
eA		15.55	15.95		0.612	0.628
eB		3.20	3.61		0.126	0.142
L		2.03	2.29		0.080	0.090

## 6 Part numbering

**Table 15. Ordering information scheme**

Example:	M48Z	35Y	-70	MH	1	E
<b>Device type</b>	M48Z					
<b>Supply voltage and write protect voltage</b>	35 <sup>(1)</sup> = V <sub>CC</sub> = 4.75 to 5.5 V; V <sub>PFD</sub> = 4.5 to 4.75 V 35Y = V <sub>CC</sub> = 4.5 to 5.5 V; V <sub>PFD</sub> = 4.2 to 4.5 V					
<b>Speed</b>	-70 = 70 ns					
<b>Package</b>	PC = PCDIP28 MH <sup>(2)</sup> = SOH28					
<b>Temperature range</b>	1 = 0 to 70 °C					
<b>Shipping method</b>	For SOH28: E = Lead-free ECOPACK <sup>®</sup> package, tubes F = Lead-free ECOPACK <sup>®</sup> package, tape & reel  For PCDIP28: blank = Tubes					

1. The M48Z35 part is offered with the PCDIP28 (CAPHAT) package only.
2. The SOIC package (SOH28) requires the SNAPHAT<sup>®</sup> battery package which is ordered separately under the part number "M4Zxx-BR00SH1" in plastic tubes (see [Table 16](#)).

**Caution:** Do not place the SNAPHAT battery package "M4Zxx-BR00SH1" in conductive foam as it will drain the lithium button-cell battery.

For other options, or for more information on any aspect of this device, please contact the ST sales office nearest you.

**Table 16. SNAPHAT<sup>®</sup> battery table**

Part number	Description	Package
M4Z28-BR00SH1	Lithium battery (48 mAh) SNAPHAT <sup>®</sup>	SH
M4Z32-BR00SH1	Lithium battery (120 mAh) SNAPHAT <sup>®</sup>	SH

## 7 Environmental information

Figure 15. Recycling symbols



This product contains a non-rechargeable lithium (lithium carbon monofluoride chemistry) button cell battery fully encapsulated in the final product.

Recycle or dispose of batteries in accordance with the battery manufacturer's instructions and local/national disposal and recycling regulations.

Please refer to the following web site address for additional information regarding compliance statements and waste recycling.

Go to [www.st.com/nvram](http://www.st.com/nvram), then select "Lithium Battery Recycling" from "Related Topics".

## 8 Revision history

**Table 17. Document revision history**

Date	Revision	Changes
Aug-1999	1	First issue
21-Apr-2000	1.1	SH and SH28 packages for 2-pin and 2-socket removed
10-May-2001	2	Reformatted; added temperature information ( <a href="#">Table 9</a> , <a href="#">10</a> , <a href="#">3</a> , , <a href="#">5</a> , <a href="#">6</a> )
29-May-2002	2.1	Modified reflow time and temperature footnotes ( <a href="#">Table 7</a> )
02-Apr-2003	3	v2.2 template applied; test condition updated ( <a href="#">Table 6</a> )
03-Mar-2004	4	Reformatted; updated with Lead-free information ( <a href="#">Table 7</a> , <a href="#">15</a> )
20-Aug-2004	5	Reformatted; remove references to 'crystal' (cover page)
09-Jun-2005	6	Removal of SNAPHAT <sup>®</sup> , industrial temperature sales types ( <a href="#">Table 3</a> , , <a href="#">5</a> , <a href="#">6</a> , <a href="#">7</a> , <a href="#">8</a> , <a href="#">10</a> , <a href="#">15</a> )
02-Nov-2007	7	Reformatted; added lead-free second level interconnect information to cover page and <a href="#">Section 5: Package mechanical data</a> ; updated <a href="#">Table 7</a> , <a href="#">15</a> , <a href="#">16</a> .
25-Mar-2009	8	Updated <a href="#">Table 7</a> , text in <a href="#">Section 5: Package mechanical data</a> ; added <a href="#">Section 7: Environmental information</a> .
19-Aug-2010	9	Updated <a href="#">Section 3</a> , <a href="#">Table 11</a> ; reformatted document.

**Please Read Carefully:**

Information in this document is provided solely in connection with ST products. STMicroelectronics NV and its subsidiaries ("ST") reserve the right to make changes, corrections, modifications or improvements, to this document, and the products and services described herein at any time, without notice.

All ST products are sold pursuant to ST's terms and conditions of sale.

Purchasers are solely responsible for the choice, selection and use of the ST products and services described herein, and ST assumes no liability whatsoever relating to the choice, selection or use of the ST products and services described herein.

No license, express or implied, by estoppel or otherwise, to any intellectual property rights is granted under this document. If any part of this document refers to any third party products or services it shall not be deemed a license grant by ST for the use of such third party products or services, or any intellectual property contained therein or considered as a warranty covering the use in any manner whatsoever of such third party products or services or any intellectual property contained therein.

**UNLESS OTHERWISE SET FORTH IN ST'S TERMS AND CONDITIONS OF SALE ST DISCLAIMS ANY EXPRESS OR IMPLIED WARRANTY WITH RESPECT TO THE USE AND/OR SALE OF ST PRODUCTS INCLUDING WITHOUT LIMITATION IMPLIED WARRANTIES OF MERCHANTABILITY, FITNESS FOR A PARTICULAR PURPOSE (AND THEIR EQUIVALENTS UNDER THE LAWS OF ANY JURISDICTION), OR INFRINGEMENT OF ANY PATENT, COPYRIGHT OR OTHER INTELLECTUAL PROPERTY RIGHT.**

**UNLESS EXPRESSLY APPROVED IN WRITING BY AN AUTHORIZED ST REPRESENTATIVE, ST PRODUCTS ARE NOT RECOMMENDED, AUTHORIZED OR WARRANTED FOR USE IN MILITARY, AIR CRAFT, SPACE, LIFE SAVING, OR LIFE SUSTAINING APPLICATIONS, NOR IN PRODUCTS OR SYSTEMS WHERE FAILURE OR MALFUNCTION MAY RESULT IN PERSONAL INJURY, DEATH, OR SEVERE PROPERTY OR ENVIRONMENTAL DAMAGE. ST PRODUCTS WHICH ARE NOT SPECIFIED AS "AUTOMOTIVE GRADE" MAY ONLY BE USED IN AUTOMOTIVE APPLICATIONS AT USER'S OWN RISK.**

Resale of ST products with provisions different from the statements and/or technical features set forth in this document shall immediately void any warranty granted by ST for the ST product or service described herein and shall not create or extend in any manner whatsoever, any liability of ST.

ST and the ST logo are trademarks or registered trademarks of ST in various countries.

Information in this document supersedes and replaces all information previously supplied.

The ST logo is a registered trademark of STMicroelectronics. All other names are the property of their respective owners.

© 2010 STMicroelectronics - All rights reserved

STMicroelectronics group of companies

Australia - Belgium - Brazil - Canada - China - Czech Republic - Finland - France - Germany - Hong Kong - India - Israel - Italy - Japan - Malaysia - Malta - Morocco - Philippines - Singapore - Spain - Sweden - Switzerland - United Kingdom - United States of America

[www.st.com](http://www.st.com)