

LOC		DIST		REVISIONS			
CM	00	P	LTN	DESCRIPTION	DATE	DWN	APVD
		RI		REVISED PER ECR-12-011660	04FEB2013	KH	TM

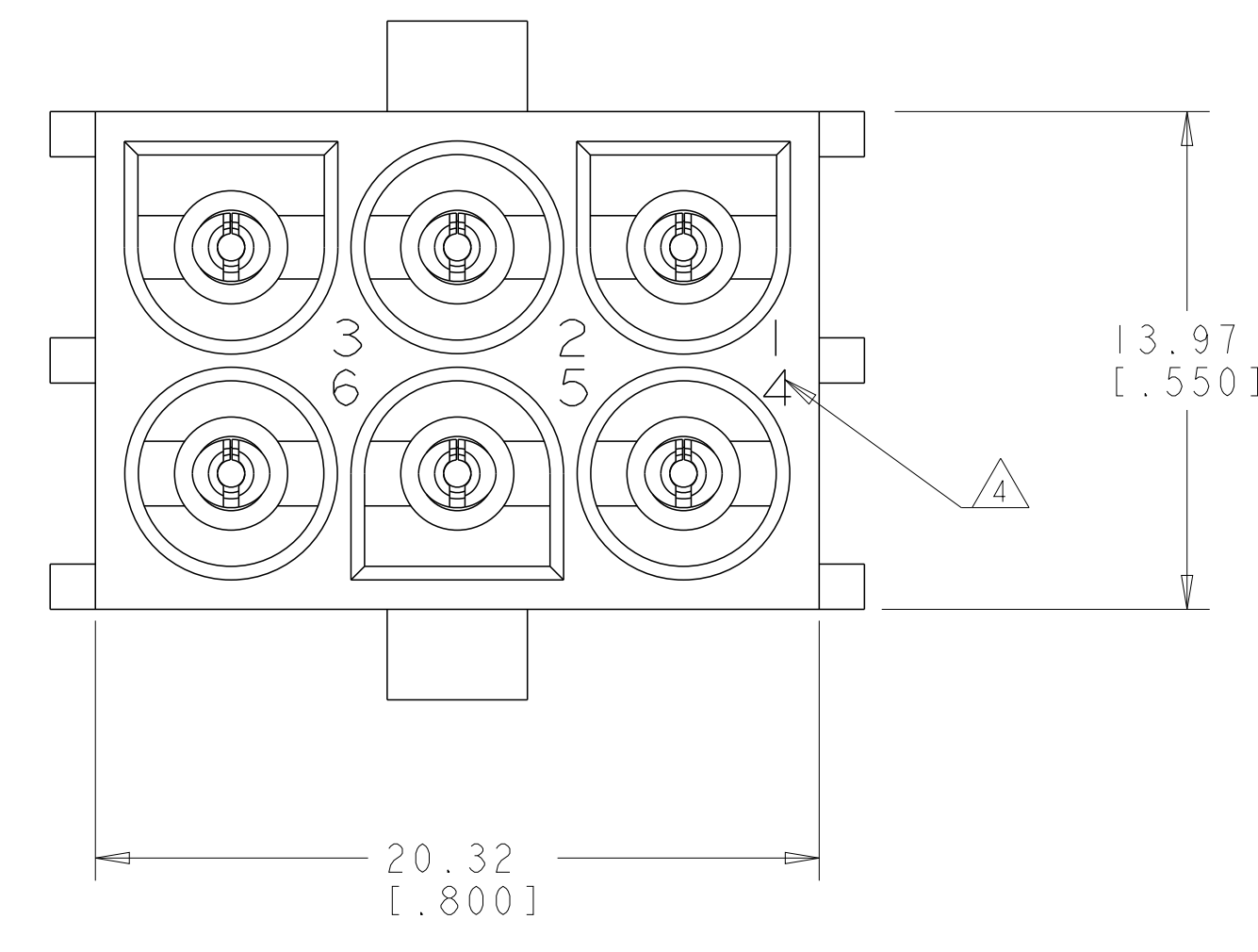

1. PARTS COMPLY TO AMP SOLDERABILITY SPECIFICATION 109-11-3.
2. CONTACT IS PLATED OVERALL WITH 0.00127 [.000050] NICKEL, THEN 0.00076 [.000030] GOLD OVER CONTACT LENGTH INDICATED AND TIN LEAD ON SOLDER TAIL END.
3. PARTS MATE WITH HOUSING 350715.
4. CIRCUIT IDENTIFICATION CHARACTERS ARE ADJACENT TO THE INDICATED CAVITIES, BUT LOCATION AND ORIENTATION MAY DIFFER FROM PRINT.
5. CONTACT IS PLATED OVERALL WITH 0.00127 [.000050] NICKEL, THEN 0.00076 [.000030] GOLD OVER CONTACT LENGTH INDICATED AND MATTE TIN ON SOLDER TAIL END.
6. DIMENSIONS IN BRACKETS ARE IN INCHES.
7. SUPERSEDED BY 350732-4

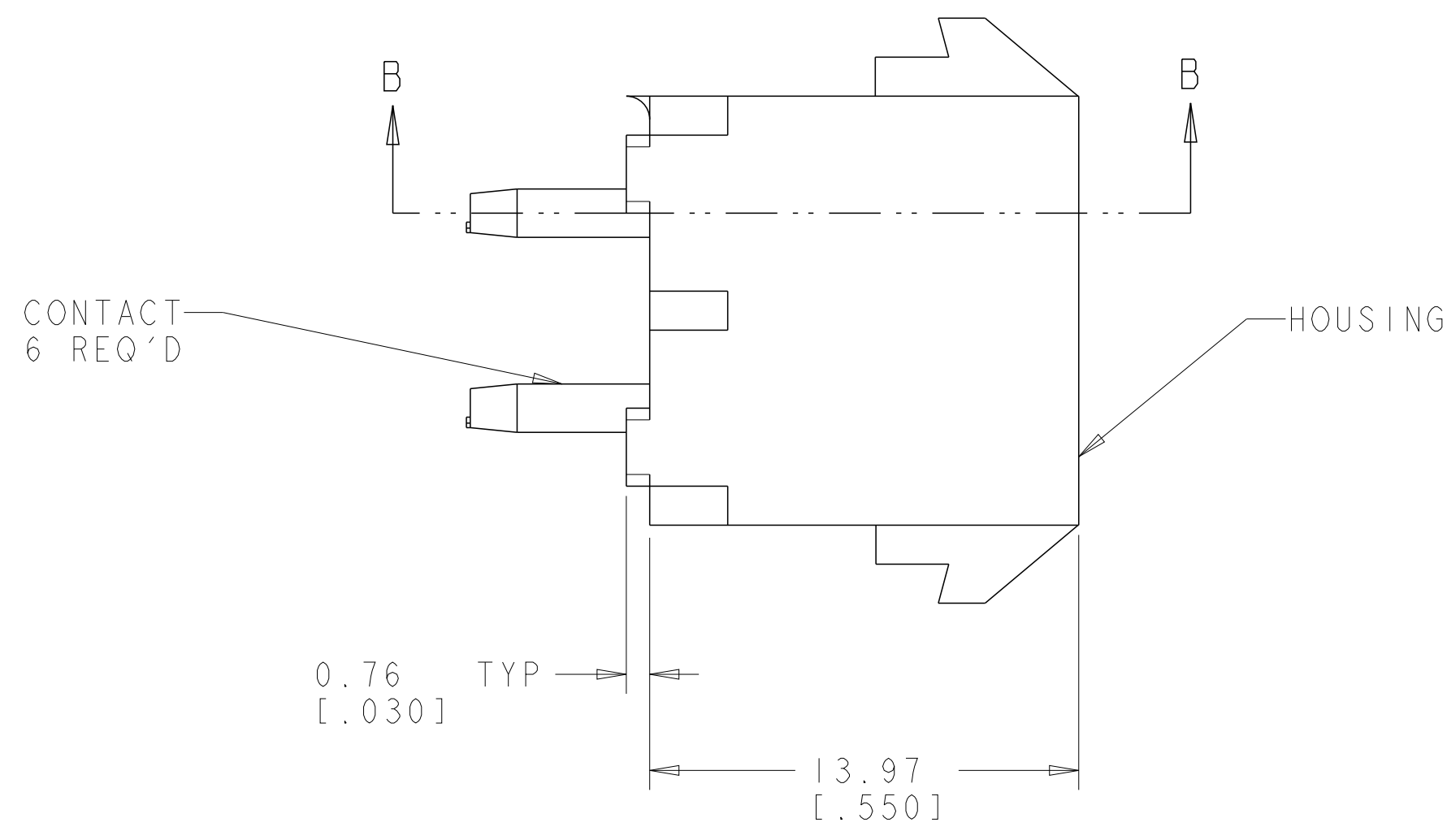
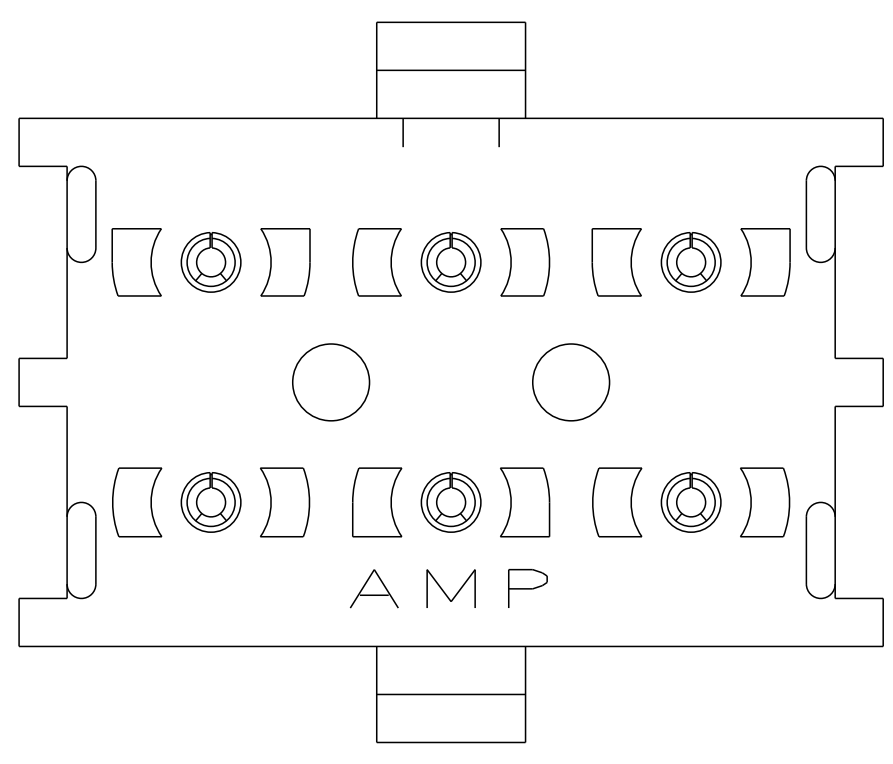
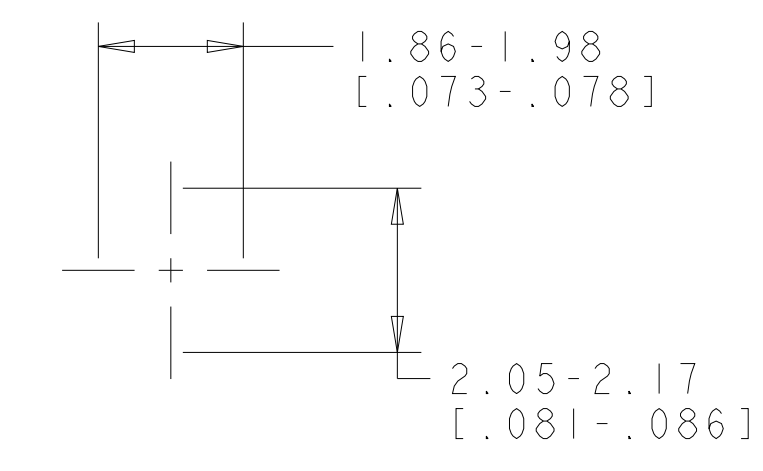
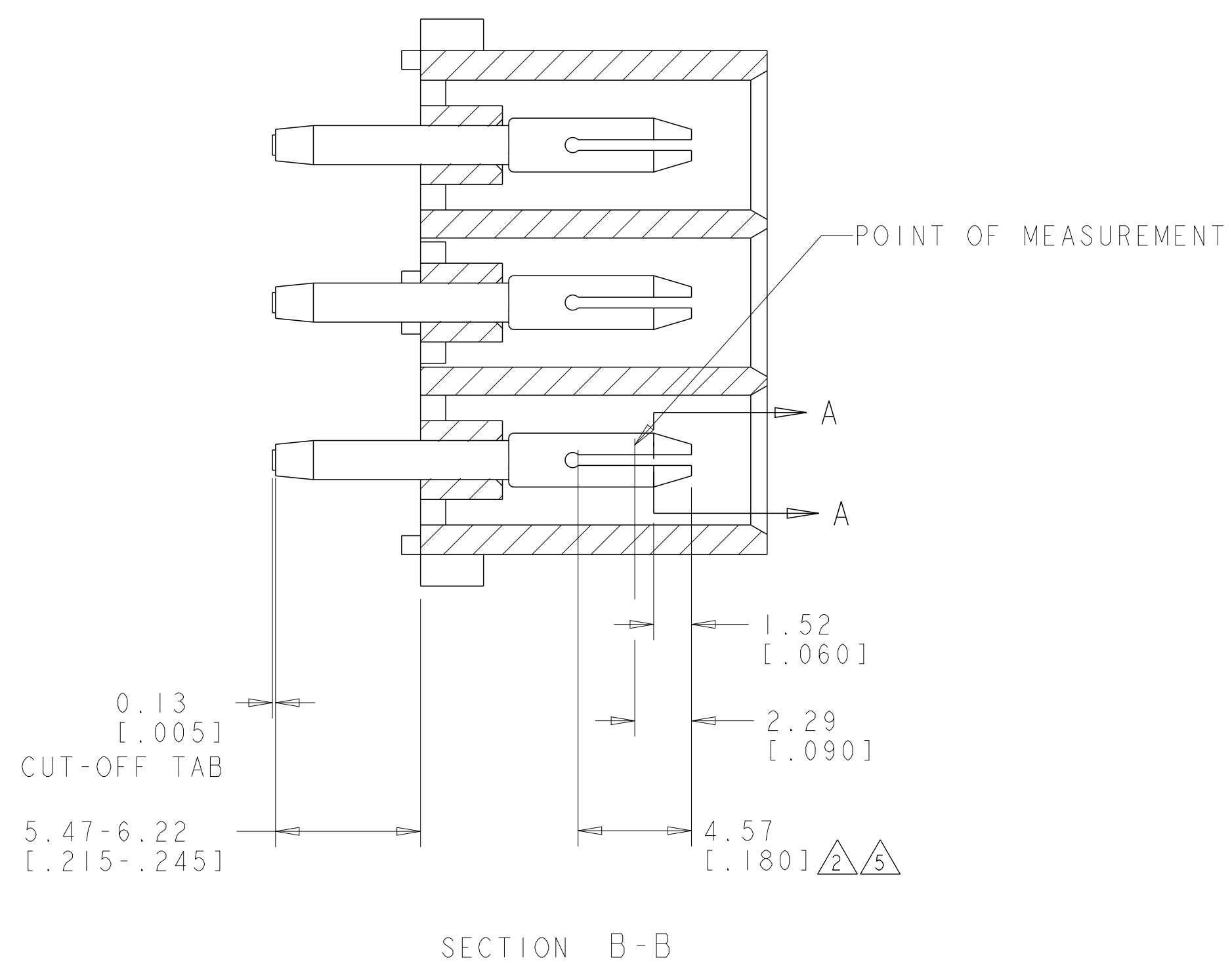

SECTION A-A  
SCALE 10:1

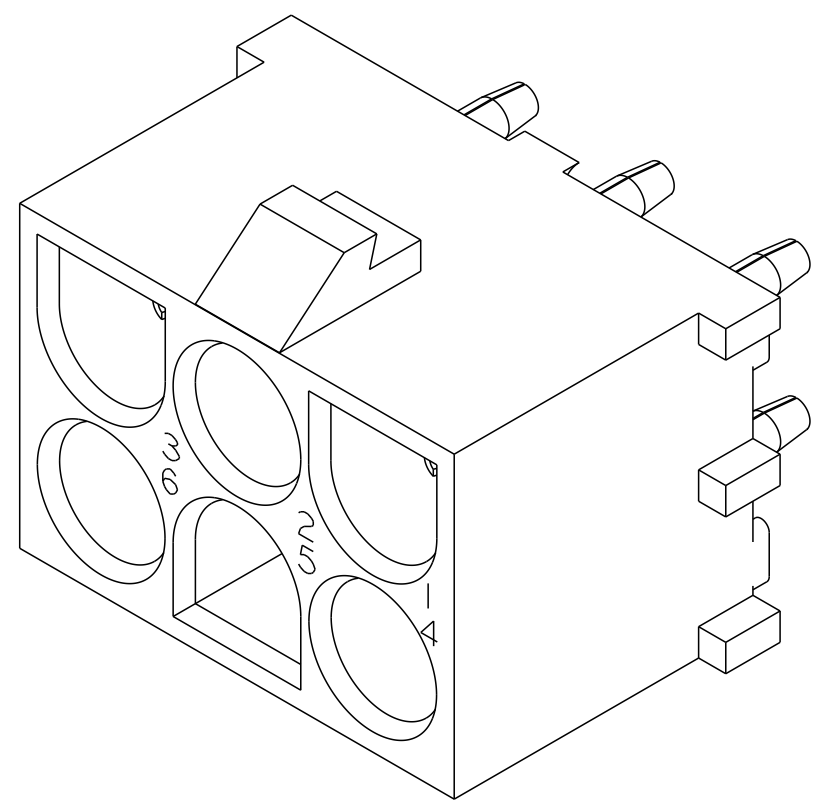

3 DIMENSIONAL MODEL  
SCALE 4:1

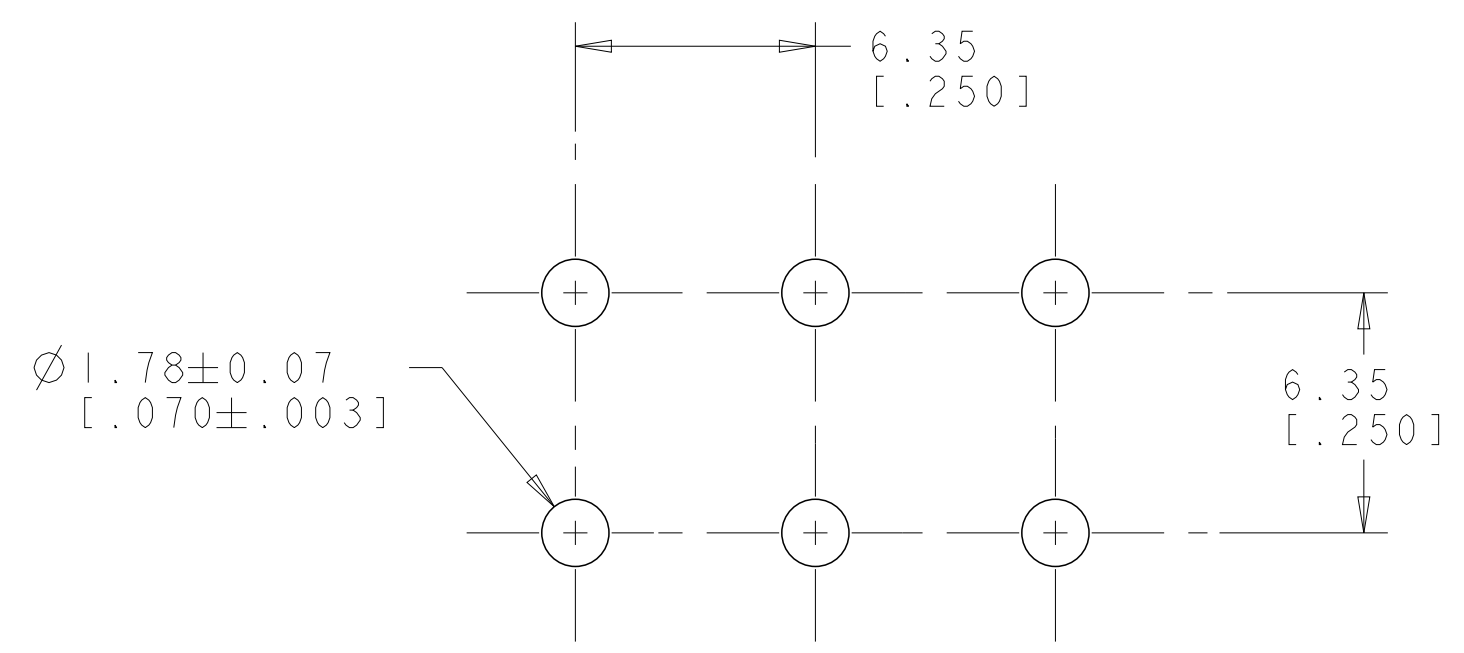

RECOMMENDED MOUNTING HOLE PATTERN  
FOR 1.57 [.062] THICK P.C. BOARD

PHOSPOR BRONZE, GOLD 5	NYLON, UL94V-0, NATURAL	350732-4
PHOSPOR BRONZE, GOLD 2	NYLON, UL94V-0, NATURAL	350732-2
PHOSPOR BRONZE, PRE-TIN	NYLON, UL94V-0, NATURAL	350732-1
PIN CONTACT MATERIAL AND FINISH	HOUSING MATERIAL AND COLOR	PART NUMBER

THIS DRAWING IS A CONTROLLED DOCUMENT.		DWN K. WHITAKER 05OCT2005	TE Connectivity
DIMENSIONS: mm [INCHES]		CHK S. RIDGILL 05OCT2005	
TOLERANCES UNLESS OTHERWISE SPECIFIED:		APVD S. RIDGILL 05OCT2005	
0 PLC ± 1 PLC ± 2 PLC ±0.131(.005) 3 PLC ± 4 PLC ± ANGLES 40°/30°		NAME APPLICATION SPEC PRODUCT SPEC	
MATERIAL SEE TABLE	FINISH SEE TABLE	WEIGHT	SIZE CAGE CODE DRAWING NO A100779C=350732 RESTRICTED TO
CUSTOMER DRAWING		SCALE 1:1	SHEET 1 OF 1 REV RI