

**HIGH EFF. RED HLMP-3300    HIGH EFF. RED HLMP-3315  
HIGH EFF. RED HLMP-3301    HIGH EFF. RED HLMP-3316  
STANDARD RED FLV110**

**PACKAGE DIMENSIONS**

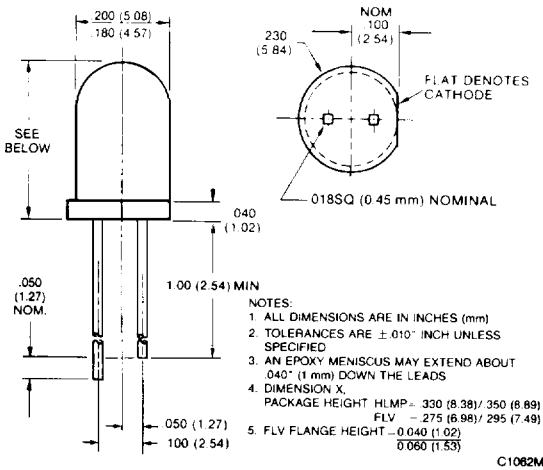

**DESCRIPTION**

Direct replacements for popular T-1¼ lamps from Fairchild and Hewlett-Packard. The FLV110 is a Standard Red Lamp with a low profile (.285 inch) lens. HLMP-33XX parts are High Efficiency Red with a standard T-1¼ package.

FLV110, HLMP-3300 and HLMP-3301 are diffused. HLMP-3315 and HLMP-3316 are non-diffused.

**FEATURES**

- Replace Fairchild and Hewlett-Packard devices
- Popular, general purpose lamps
- Wide and narrow viewing angle devices for direct view or backlighting
- Solid state reliability
- Sturdy leads for easier assembly

Temperature									
PARAMETER		SYMBOL	HLMP-3300	HLMP-3301	HLMP-3315	HLMP-3316	FLV* 110	UNITS	TEST CONDITIONS
Luminous Intensity	min.	$I_v$	2.0	4.0	12	20	0.8*	mcd	$I_f=10$ mA
	typ.		3.5	7.0	18	35	3.0*	mcd	$I_f=10$ mA
Forward voltage	max.	$V_f$	3.0	3.0	3.0	3.0	2.0	V	$I_f=10$ mA
	typ.		2.2	2.2	2.2	2.2	1.6	V	$I_f=10$ mA
Peak wavelength	typ.	$\lambda_p$	635	635	635	635	665	nm	$I_f=10$ mA
Capacitance	typ.	C	45	45	45	45	30	pF	V=0, f=1 MHz
Reverse breakdown voltage	min.	$V_{BR}$	5	5	5	5	5	V	$I_R=100\mu$ A
Total viewing angle between half Luminous Intensity Points	typ.	$2\theta_{1/2}$	65	65	35	35	70	degrees	

\*For FLV110 Test  $I_f=20$  mA

Absolute Maximum Ratings (Unless Specified)	
Power dissipation	135 mW
Derate linearly from 25°C	1.8 mW/°C
Storage and operating temperatures	-55°C to +100°C
Lead soldering time @ 260°C (See Note 1)	5 sec.
Continuous forward current	30 mA
Peak forward current (1 $\mu$ sec pulse, 0.3% duty cycle) (FLV110 1 amp)	90 mA
Reverse voltage	5.0 V

NOTES
1. From a point minimum 1/16 inch (1.6 mm) from the bottom of the lamp.

FLV110 HLMP-3300 HLMP-3301 HLMP-3315 HLMP-3316

**TYPICAL ELECTRO-OPTICAL CHARACTERISTICS CURVES**  
(25°C Free Air Temperature Unless Otherwise Specified)

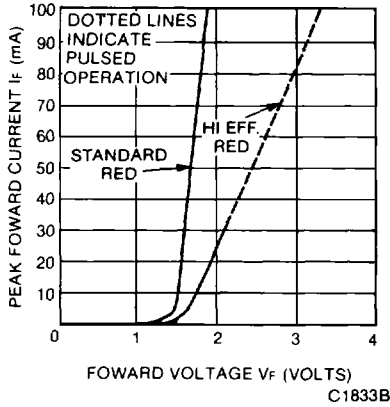

Fig. 1. Forward Current vs. Forward Voltage

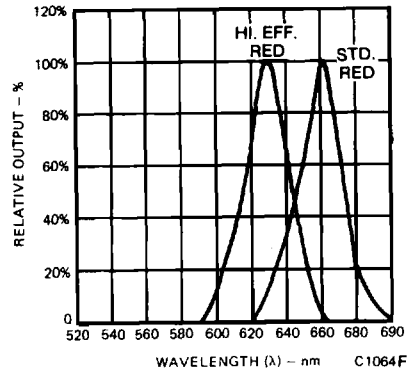

Fig. 2. Spectral Distribution

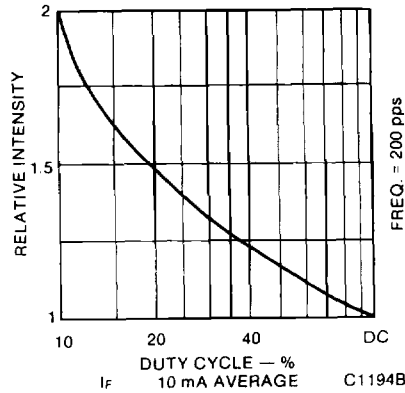

Fig. 3. Luminous Intensity vs. Duty Cycle



FLV110 HLMP-3300 HLMP-3301 HLMP-3315 HLMP-3316