



MAXIM

Triple-Output Power-Supply Controller for Notebook Computers

MAX783

General Description

The MAX783 is a system-engineered power-supply controller for notebook computers or similar battery-powered equipment. It provides two high-performance step-down (buck) pulse-width modulators (PWMs) for +3.3V/+5V and dual PCMCIA VPP outputs powered by an integral flyback winding controller. Other functions include dual, low-dropout, micropower linear regulators for CMOS/RTC back up, and two precision low-battery-detection comparators.

High efficiency (95% at 2A, greater than 80% at loads from 5mA to 3A) is achieved through synchronous rectification and PWM operation at heavy loads, and Idle-Mode™ operation at light loads. The MAX783 uses physically small components, thanks to high operating frequencies (300kHz/200kHz) and a new current-mode PWM architecture that allows for output filter capacitors as small as 30µF per ampere of load. Line- and load-transient responses are terrific, with a high 60kHz unity-gain crossover frequency that allows output transients to be corrected within four or five clock cycles. Low system cost is achieved through a high level of integration and the use of low-cost external N-channel MOSFETs. The integral flyback winding controller provides a low-cost, +15V high-side output that regulates even in the absence of a load on the main output.

Other features include low-noise, fixed-frequency PWM operation at moderate to heavy loads and a synchronizable oscillator for noise-sensitive applications such as electromagnetic pen-based systems and communicating computers. The MAX783 is similar to the MAX782, except the flyback winding is on the 3.3V inductor instead of the 5V inductor, the VPP outputs can be optionally programmed to 3.3V, and the device may be completely shut down.

Applications

Notebook Computers
Portable Data Terminals
Communicating Computers
Pen-Entry Systems

Typical Application Diagram

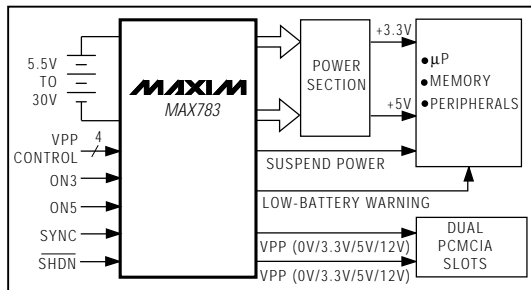

Features

- ♦ Dual PWM Buck Controllers (+3.3V and +5V)
- ♦ Dual PCMCIA VPP Outputs (0V/3.3V/5V/12V)
- ♦ Two Precision Comparators or Level Translators
- ♦ Power-Ready Status Output (RDY5)
- ♦ 95% Efficiency
- ♦ Optimized for 6-Cell Applications
- ♦ 420µA Quiescent Current;
70µA in Standby (linear regulators alive)
25µA Shutdown Current
- ♦ 5.5V to 30V Input Range
- ♦ Small SSOP Package
- ♦ Fixed Output Voltages Available:
3.3V (standard)
3.45V (High-Speed Pentium™)
3.6V (PowerPC™)

Ordering Information

PART	TEMP. RANGE	PIN-PACKAGE	V _{OUT}
MAX783CBX	0°C to +70°C	36 SSOP	3.3V
MAX783RCBX	0°C to +70°C	36 SSOP	3.45V

Ordering Information continued on last page.

Pin Configuration

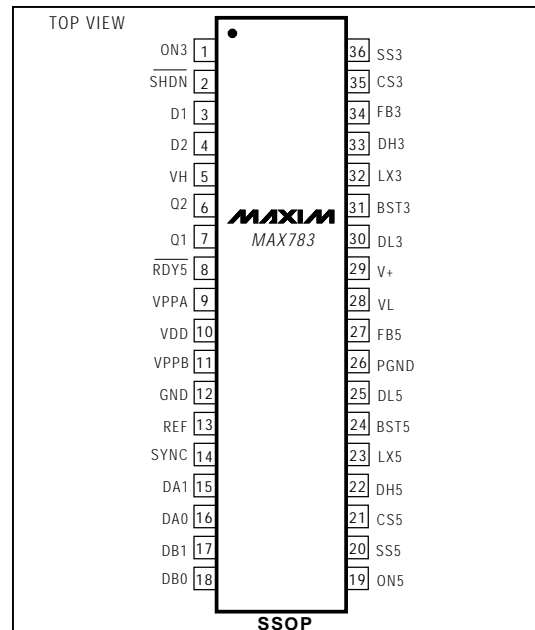

™ Idle-Mode is a trademark of Maxim Integrated Products. Pentium is a trademark of Intel. PowerPC is a trademark of IBM.

MAXIM

Maxim Integrated Products 1

Call toll free 1-800-998-8800 for free samples or literature.

Triple-Output Power-Supply Controller for Notebook Computers

MAX783

ABSOLUTE MAXIMUM RATINGS

V+ to GND	-0.3V, +36V	DH3 to LX3	-0.3V, (BST3 + 0.3V)
PGND to GND	±2V	DH5 to LX5	-0.3V, (BST5 + 0.3V)
VL to GND	-0.3V, +7V	REF, VL, VPP Short to GND	Momentary
BST3, BST5 to GND	-0.3V, +36V	REF Current	20mA
LX3 to BST3	-7V, +0.3V	VL Current	50mA
LX5 to BST5	-7V, +0.3V	VPPA, VPPB Current	100mA
Inputs/Outputs to GND		Continuous Power Dissipation (T _A = +70°C)	
(D1, D2, SHDN, ON5, REF, SYNC, DA1, DA0, DB1, DB0, ON5, SS5, CS5, FB5, RDY5, CS3, FB3, SS3, ON3)	-0.3V, (VL + 0.3V)	SSOP (derate 11.76mW/°C above +70°C)	762mW
VDD to GND	-0.3V, 20V	Operating Temperature Ranges:	
VPPA, VPPB to GND	-0.3V, (VDD + 0.3V)	MAX783CBX/MAX783_CBX	0°C to +70°C
VH to GND	-0.3V, 20V	MAX783EBX/MAX783_EBX	-40°C to +85°C
Q1, Q2 to GND	-0.3V, (VH + 0.3V)	Storage Temperature Range	-65°C to +160°C
DL3, DL5 to PGND	-0.3V, (VL + 0.3V)	Lead Temperature (soldering, 10sec)	+300°C

Stresses beyond those listed under "Absolute Maximum Ratings" may cause permanent damage to the device. These are stress ratings only, and functional operation of the device at these or any other conditions beyond those indicated in the operational sections of the specifications is not implied. Exposure to absolute maximum rating conditions for extended periods may affect device reliability.

ELECTRICAL CHARACTERISTICS

(V+ = 15V, GND = PGND = 0V, I_{VL} = I_{REF} = 0mA, SHDN = ON3 = ON5 = 5V, other digital input levels are 0V or +5V, T_A = T_{MIN} to T_{MAX}, unless otherwise noted.)

PARAMETER	CONDITIONS	MIN	TYP	MAX	UNITS
3.3V AND 5V STEP-DOWN CONTROLLERS					
Input Supply Range		5.5		30	V
FB5 Output Voltage	0mV < (CS5-FB5) < 70mV, 6V < V+ < 30V (includes load and line regulation)	4.80	5.08	5.20	V
FB3 Output Voltage	0mV < (CS3-FB3) < 70mV, 6V < V+ < 30V (includes load and line regulation)	MAX783	3.17	3.35	3.46
		MAX783R	3.32	3.50	3.60
		MAX783S	3.46	3.65	3.75
Load Regulation	Either controller (0mV to 70mV)		2.5		%
Line Regulation	Either controller (6V to 30V)		0.03		%/V
Current-Limit Voltage	CS3-FB3 or CS5-FB5	80	100	120	mV
	CS3-FB3 (VDD < 13V, flyback mode)	-50	-100	-160	
SS3/SS5 Source Current		2.5	4.0	6.5	µA
SS3/SS5 Fault Sink Current		2			mA
15V FLYBACK CONTROLLER					
VDD Regulation Setpoint	Falling edge, hysteresis = 1%	13		14	V
VDD Shunt Setpoint	Rising edge, hysteresis = 1%	18		20	V
VDD Shunt Current	VDD = 20V	2	3		mA
Quiescent VDD Current	VDD = 18V, ON3 = ON5 = 5V, VPPA/VPPB programmed to 12V with no external load		140	300	µA
Off VDD Current	VDD = 18V, ON3 = ON5 = 5V, VPPA/VPPB programmed to 0V		15	30	µA
PCMCIA REGULATORS (Note 1)					
VPPA/VPPB Output Voltage	Program to 12V, 13V < VDD < 19V, 0mA < I _L < 60mA	11.60	12.10	12.50	V
	Program to 5V, 13V < VDD < 19V, 0mA < I _L < 60mA	4.85	5.05	5.20	
	Program to 3.3V, 13V < VDD < 19V, 0mA < I _L < 60mA	3.17	3.30	3.43	
	Program to 0V, 13V < VDD < 19V, 0mA < I _L < 0.3mA	-0.30		0.30	

Triple-Output Power-Supply Controller for Notebook Computers

MAX783

ELECTRICAL CHARACTERISTICS (continued)

(V+ = 15V, GND = PGND = 0V, I_{VL} = I_{REF} = 0mA, SHDN = ON3 = ON5 = 5V, other digital input levels are 0V or +5V, T_A = T_{MIN} to T_{MAX}, unless otherwise noted.)

PARAMETER	CONDITIONS	MIN	TYP	MAX	UNITS
INTERNAL REGULATOR AND REFERENCE					
VL Output Voltage	ON5 = ON3 = 0V, 5.5V < V+ < 30V, 0mA < I _L < 25mA	4.5		5.5	V
VL Fault Lockout Voltage	Falling edge, hysteresis = 1%	3.6		4.2	V
VL/FB5 Switchover Voltage (also RDY5 Trip Voltage)	Rising edge of FB5, hysteresis = 1%	4.2		4.7	V
REF Output Voltage	No external load (Note 2)	3.24		3.36	V
REF Fault Lockout Voltage	Falling edge	2.4		3.2	V
REF Load Regulation	0mA < I _L < 5mA (Note 3)		30	75	mV
Shutdown V+ Current	SHDN = D1 = D2 = ON3 = ON5 = DA0 = DA1 = DB0 = DB1 = 0V, V+ = 30V		25	40	μA
Standby V+ Current	D1 = D2 = ON3 = ON5 = DA0 = DA1 = DB0 = DB1 = 0V, V+ = 30V		70	110	μA
Quiescent Power Consumption (both controllers on)	D1 = D2 = D3 = DA0 = DA1 = DB0 = DB1 = 0V, FB5 = CS5 = 5.25V, FB3 = CS3 = 3.5V		5.2	8.6	mW
Off V+ Current	FB5 = CS5 = 5.25V, VL switched over to FB5		30	60	μA
COMPARATORS					
D1, D2 Trip Voltage	Falling edge, hysteresis = 1%	1.61		1.69	V
D1, D2 Input Current	D1 = D2 = 0V to 5V			±100	nA
Q1, Q2 RDY5 Source Current	VH = 15V, V _{OUT} = 2.5V	12	20	30	μA
Q1, Q2 RDY5 Sink Current	VH = 15V, V _{OUT} 2.5V	200	500	1000	μA
Q1, Q2, RDY5 Output High Voltage	I _{SOURCE} = 5μA, VH = 3V		VH - 0.5		V
Q1, Q2, RDY5 Output Low Voltage	I _{SINK} = 20μA, VH = 3V			0.4	V
Quiescent VH Current	VH = 18V, D1 = D2 = 5V, no external load		4	10	μA
OSCILLATOR AND INPUTS/OUTPUTS					
Oscillator Frequency	SYNC = 3.3V	270	300	330	kHz
	SYNC = 0V or 5V	170	200	230	
SYNC High Pulse Width		200			ns
SYNC Low Pulse Width		200			ns
SYNC Rise/Fall Time	Not tested			200	ns
Oscillator SYNC Range		240		350	kHz
Maximum Duty Cycle	SYNC = 3.3V	89	92		%
	SYNC = 0V or 5V	92	95		
Input Low Voltage	SHDN, ON3, ON5, DA0, DA1, DB0, DB1, SYNC			0.8	V
Input High Voltage	SHDN, ON3, ON5, DA0, DA1, DB0, DB1	2.4			V
	SYNC	VL - 0.5			
Input Current	SHDN, ON3, ON5, DA0, DA1, DB0, DB1, V _{IN} = 0V or 5V			±1	μA

Triple-Output Power-Supply Controller for Notebook Computers

ELECTRICAL CHARACTERISTICS (continued)

($V_+ = 15V$, $GND = PGND = 0V$, $I_{VL} = I_{REF} = 0mA$, $SHDN = ON3 = ON5 = 5V$, other digital input levels are $0V$ or $+5V$, $T_A = T_{MIN}$ to T_{MAX} , unless otherwise noted.)

PARAMETER	CONDITIONS	MIN	TYP	MAX	UNITS
DL3/DL5 Sink/Source Current	$V_{OUT} = 2V$		1		A
DH3/DH5 Sink/Source Current	$BST3-LX3 = BST5-LX5 = 4.5V$, $V_{OUT} = 2V$		1		A
DL3/DL5 On-Resistance	High or low			7	Ω
DH3/DH5 On-Resistance	High or low, $BST3-LX3 = BST5-LX5 = 4.5V$			7	Ω

Note 1: Output current is further limited by maximum allowable package power dissipation.

Note 2: Because the reference uses VL as its supply, the REF line regulation error is insignificant.

Note 3: The main switching outputs track the reference voltage. Loading the reference reduces the main outputs slightly according to the closed-loop gain (AV_{CL}) and the reference voltage load regulation error. AV_{CL} for the $+3.3V$ supply is unity gain. AV_{CL} for the $+5V$ supply is 1.54.

Typical Operating Characteristics

(Circuit of Figure 1, Transpower TTI5902 transformer, $T_A = +25^\circ C$, unless otherwise noted.)

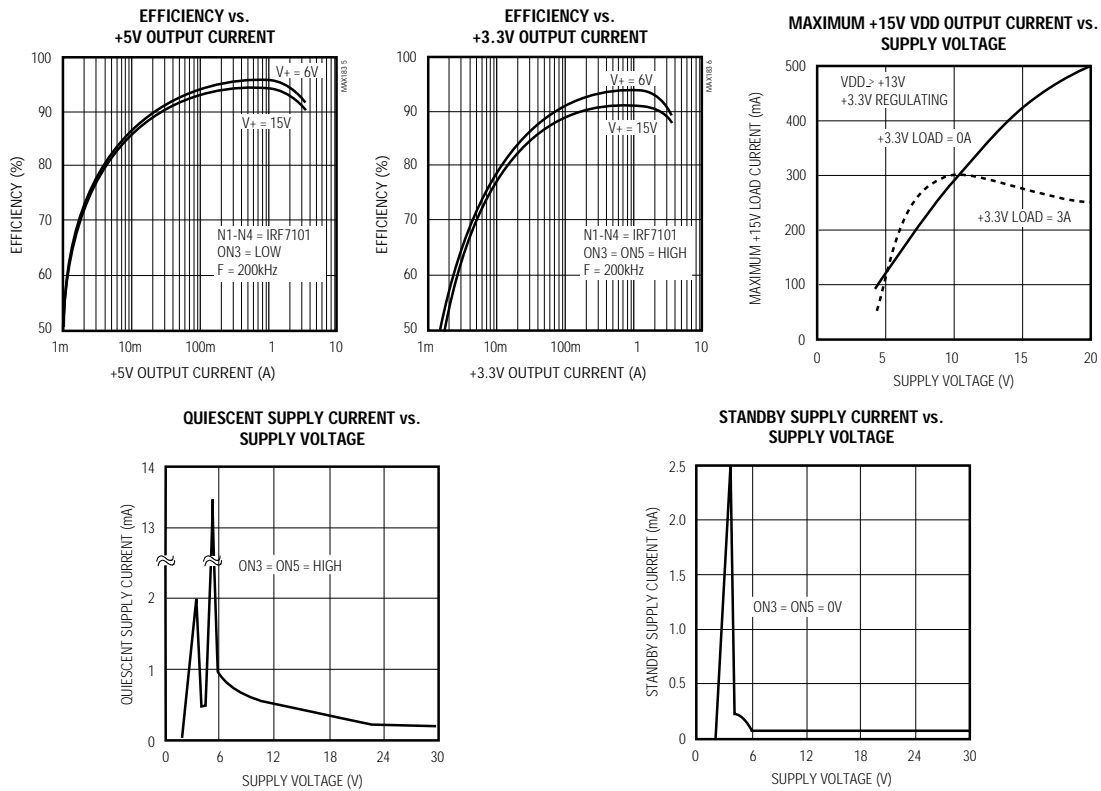

Triple-Output Power-Supply Controller for Notebook Computers

MAX783

Typical Operating Characteristics (continued)
(Circuit of Figure 1, Transpower TT15902 transformer, $T_A = +25^\circ\text{C}$, unless otherwise noted.)

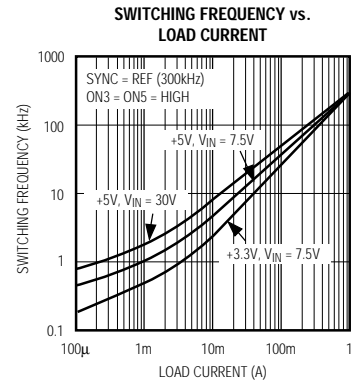
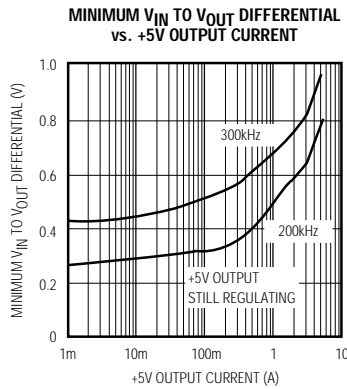
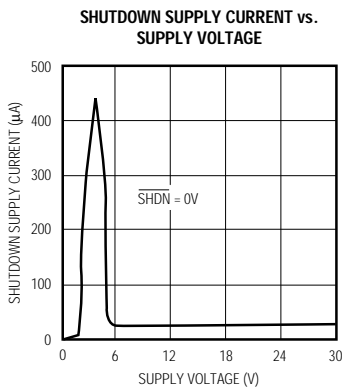

PULSE-WIDTH MODULATION MODE WAVEFORMS

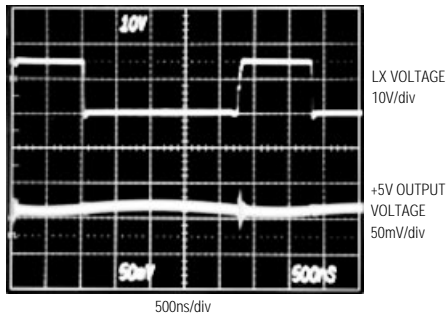

$I_{LOAD} = 1\text{A}$
 $V_{IN} = 16\text{V}$

IDLE-MODE WAVEFORMS

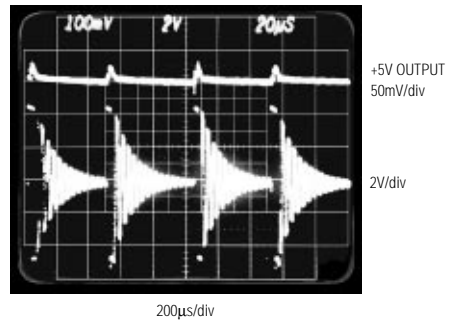

$I_{LOAD} = 100\text{mA}$
 $V_{IN} = 10\text{V}$

Triple-Output Power-Supply Controller for Notebook Computers

Typical Operating Characteristics (continued)

(Circuit of Figure 1, Transpower TT15902 transformer, $T_A = +25^\circ\text{C}$, unless otherwise noted.)

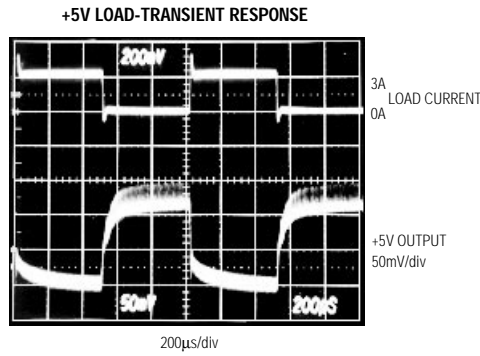

$V_{IN} = 15\text{V}$

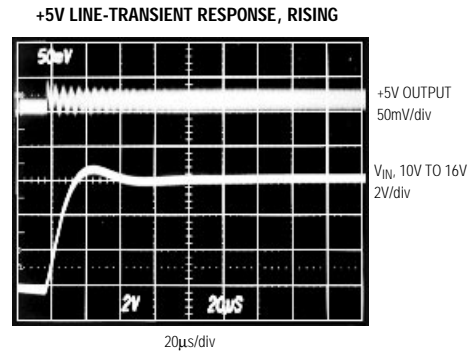

$I_{LOAD} = 2\text{A}$

+5V LINE-TRANSIENT RESPONSE, FALLING

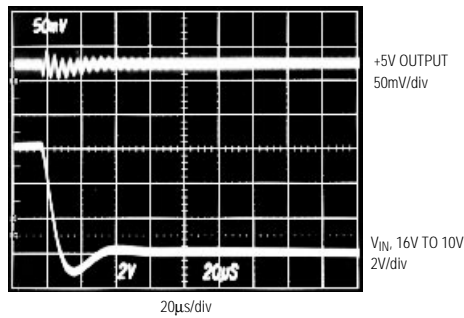

$I_{LOAD} = 2\text{A}$

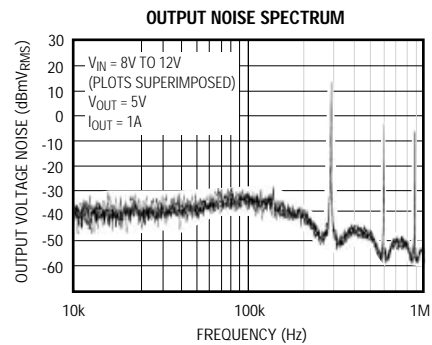
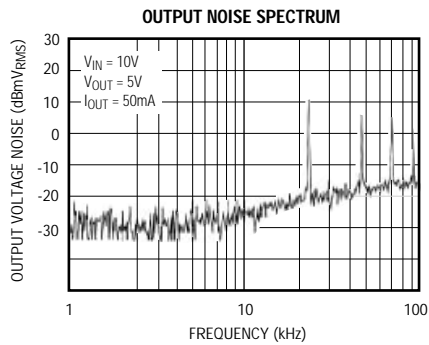

Triple-Output Power-Supply Controller for Notebook Computers

Pin Description

MAX783

PIN	NAME	FUNCTION
1	ON3	ON/OFF control input to disable the +3.3V PWM. Tie directly to VL for automatic start-up.
2	SHDN	Shutdown control input, low-true logic. Tie to VL for automatic start-up. The 5V VL supply stays active in shutdown. Don't force SHDN higher than VL + 0.5V.
3	D1	#1 level-translator/comparator noninverting input, threshold = +1.650V. Controls Q1. Tie to GND if unused.
4	D2	#2 level-translator/comparator noninverting input (see D1).
5	VH	External positive supply voltage input for the level translators/comparators and RDY5 output.
6	Q2	#2 level-translator/comparator output. Sources 20µA from VH when D2 is high. Sinks 500µA to GND when D2 is low, even with VH = 0V.
7	Q1	#1 level translator/comparator output (see Q2).
8	RDY5	Power-good indication for the main +5V supply. Low indicates greater than 4.5V at the +5V output. Swings 0V to VH.
9	VPPA	0V, 3.3V, 5V, 12V switchable PCMCIA VPP output. Sources 60mA. Controlled by DA0 and DA1.
10	VDD	+15V flyback input (feedback). A weak shunt regulator conducts 3mA to GND when VDD exceeds 19V. VDD serves as the supply input for the VPP linear regulators.
11	VPPB	0V, 3.3V, 5V, 12V switchable PCMCIA VPP output. Sources 60mA. Controlled by DB0 and DB1.
12	GND	Low-current analog ground. Feedback reference point for all outputs.
13	REF	3.3V reference output sources up to 5mA for external loads. Bypass to GND with 1µF/mA of load or 0.22µF minimum
14	SYNC	Oscillator control/synchronization input. Connect to VL or GND for 200kHz; connect to REF for 300kHz. For external clock synchronization in the 240kHz to 350kHz range, a high-to-low transition starts a new cycle.
15-18	DA1, DA0, DB1, DB0	PCMCIA digital control inputs with industry-standard coding (see Table 1).
19	ON5	ON/OFF control input to disable the +5V PWM supply. Tie to VL for automatic start-up.
20	SS5	Soft-start control input for +5V. Ramp time to full current limit is 1ms/nF of capacitance to GND.
21	CS5	Current-sense input for +5V. Current limit level is +100mV referred to FB5.
22	DH5	Gate-drive output for the +5V high-side MOSFET.
23	LX5	Inductor connection for the +5V supply.
24	BST5	Boost capacitor connection for the +5V supply (0.1µF).
25	DL5	Gate-drive output for the +5V low-side MOSFET.
26	PGND	Power ground
27	FB5	Feedback and current-sense input for the +5V PWM.
28	VL	5V logic supply voltage for internal circuitry. VL is always on and can source 5mA for external loads.
29	V+	Supply voltage input from battery, 5.5V to 30V
30	DL3	Gate-drive output for the +3.3V low-side MOSFET.
31	BST3	Boost capacitor connection for the +3.3V supply (0.1µF).
32	LX3	Inductor connection for the +3.3V supply.
33	DH3	Gate-drive output for the +3.3V high-side MOSFET.
34	FB3	Feedback and current-sense input for the +3.3V PWM.
35	CS3	Current-sense input for +3.3V, current limit level is +100mV referred to FB3.
36	SS3	Soft-start input for +3.3V. Ramp time to full current limit is 1ms/nF of capacitance to GND.

Triple-Output Power-Supply Controller for Notebook Computers

Table 1. Truth Table for VPP Control Pins

D_0	D_1	VPP
0	0	0V
0	1	5V
1	0	12V
1	1	3.3V

Detailed Description

The MAX783 converts a 5.5V to 30V input to six outputs (Figure 1). It produces two high-power, PWM switch-mode supplies, one at +5V and the other at +3.3V. The two supplies operate at either 300kHz or 200kHz, allowing for small external components. Output current capability depends on external components, and can exceed 6A on each supply. Two 12V VPP outputs, an internal 5V, 25mA supply (VL) and a 3.3V, 5mA reference voltage are also generated via linear regulators (Figure 2). Fault-protection circuitry shuts off the PWM and high-side supply when the internal supplies lose regulation.

Two precision voltage comparators are also included. Their output stages permit them to be used as level translators for driving external N-channel MOSFETs in load-switching applications, or for more conventional logic signals.

The MAX783 is capable of accepting input voltages from 5.5V to 30V, but is optimized for the lower end of this range because the +15V flyback winding controller is appended to the +3.3V buck supply. This architecture allows for lower input voltages than are possible with the MAX782 sister chip, which puts the winding on the +5V side, while maintaining high +15V load capability. However, the MAX783's transformer has a higher turns ratio (4:1 vs. 2:1), which leads to higher interwinding capacitance as well as higher switching noise amplitudes at the transformer secondary when the input voltage is high. Therefore, the MAX783 standard application circuit is optimized with external components for low-voltage (6-8 cell) designs with maximum input voltages of 20V and less. The MAX783 itself can easily accept 30V inputs, but expect to see more noise and higher voltage swings at the transformer secondary under these conditions. The inductor and filter capacitor values may also require some adjustment for inputs greater than 20V; see the *Design Procedure* section.

+5V Switch-Mode Supply

The +5V supply is generated by a current-mode PWM step-down regulator using two N-channel MOSFETs, a rectifier, plus an LC output filter (Figure 1). The gate-drive signal to the high-side MOSFET, which must exceed the battery voltage, is provided by a boost cir-

cuit that uses a 100nF capacitor connected to BST5. The +5V supply's dropout voltage, as configured in Figure 1, is typically 400mV at 2A. As V_+ approaches 5V, the +5V output falls with V_+ until the VL regulator output hits its undervoltage lockout threshold at 4V. At this point, the +5V supply turns off.

A synchronous rectifier at LX5 keeps efficiency high by effectively clamping the voltage across the rectifier diode. Maximum current limit is set by an external low-value sense resistor, which prevents excessive inductor current during start-up or under short-circuit conditions. Programmable soft-start is set by an optional external capacitor; this reduces in-rush surge currents upon start-up and provides adjustable power-up times for power-supply sequencing purposes.

+3.3V Switch-Mode Supply

The +3.3V output is produced by a current-mode PWM step-down regulator similar to the +5V supply. The +3.3V supply uses a transformer primary winding as its inductor; the secondary is used for the 15V VDD supply.

The default switching frequency for both PWM controllers is 200kHz (with SYNC connected to GND or VL), but 300kHz may be used by connecting SYNC to REF.

+3.3V and +5V PWM Buck Controllers

The two current-mode PWM buck controllers are nearly identical except for different preset output voltages and the addition of a flyback winding control loop to the 3.3V side. Each PWM is independent, except both are synchronized to a master oscillator and share a common reference (REF) and logic supply (VL). Each PWM can be turned on and off separately via ON3 and ON5. The PWMs are a direct-summing type, lacking a traditional integrator-type error amplifier and the phase shift associated with it. They therefore do not require external feedback compensation components if you follow the filter capacitor ESR guidelines in the *Design Procedure*.

The main gain block is an open-loop comparator that sums four input signals: output voltage error signal, current-sense signal, slope-compensation ramp, and precision reference voltage. This direct-summing method approaches the ideal of cycle-by-cycle control of the output voltage. Under heavy loads, the controller operates in full PWM mode. Every pulse from the oscillator sets the output latch and turns on the high-side switch for a period determined by the duty factor (approximately V_{OUT}/V_{IN}). As the high-side switch turns off, the synchronous rectifier latch is set; 60ns later, the low-side switch turns on. The low-side switch stays on until the beginning of the next clock cycle (in continuous mode) or until the inductor current crosses through

Triple-Output Power-Supply Controller for Notebook Computers

MAX783

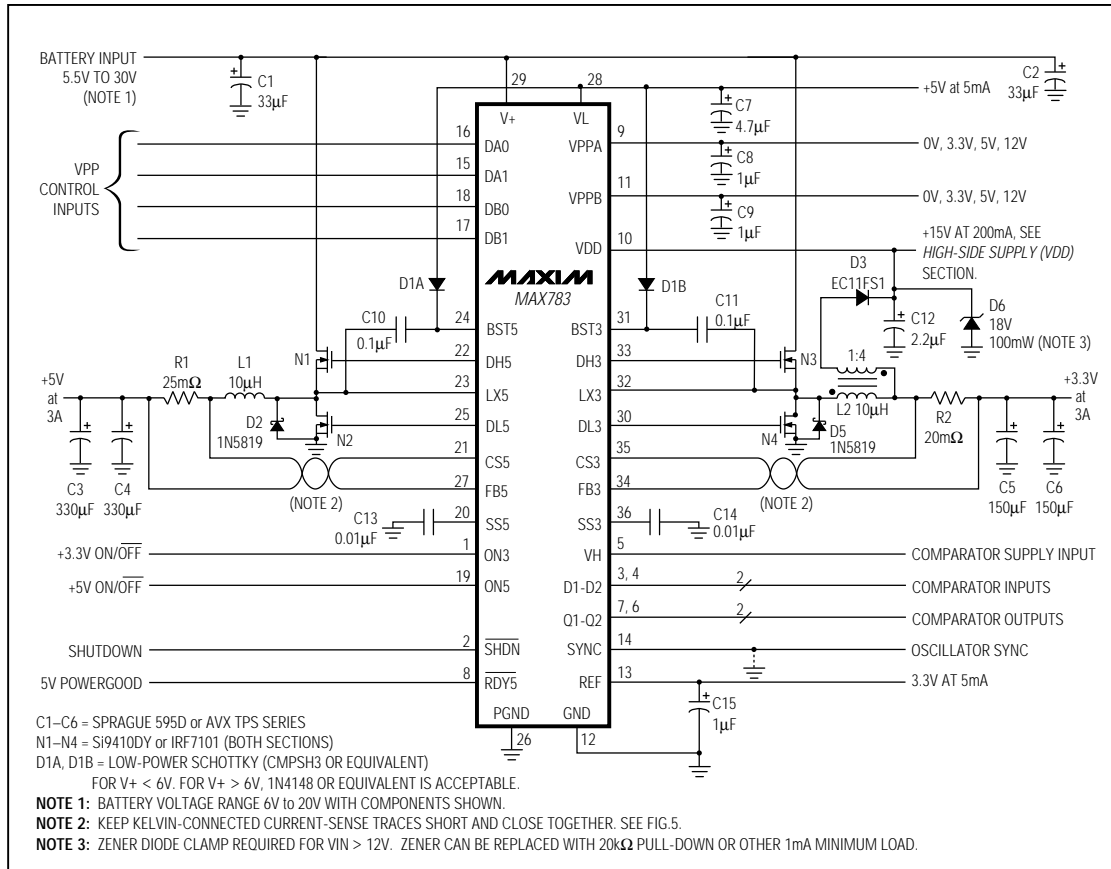

Figure 1. Standard Application Circuit

zero (in discontinuous mode). Under fault conditions when the inductor current exceeds the 100mV current-limit threshold, the high-side latch resets and the high-side switch turns off.

At light loads, the inductor current fails to exceed the 25mV threshold set by the minimum current comparator. When this occurs, the PWM goes into idle mode, skipping most of the oscillator pulses in order to reduce the switching frequency and cut back switching losses. The oscillator is effectively gated off at light loads because the minimum current comparator immediately resets the high-side latch at the beginning of each cycle, unless the FB₋ signal falls below the reference voltage level.

A flyback winding controller regulates the +15V VDD supply in the absence of a load on the main 3.3V output. If VDD falls below the preset +13V VDD regulation threshold, a 1µs one-shot is triggered that extends the low-side switch's on-time beyond the point where the inductor current crosses zero (in discontinuous mode). This causes inductor (primary) current to reverse, pulling current out of the output filter capacitor and causing the flyback transformer to operate in the forward mode. The low impedance presented by the transformer secondary in forward mode allows the +15V filter capacitor to be quickly charged up again, bringing VDD into regulation.

Triple-Output Power-Supply Controller for Notebook Computers

MAX783

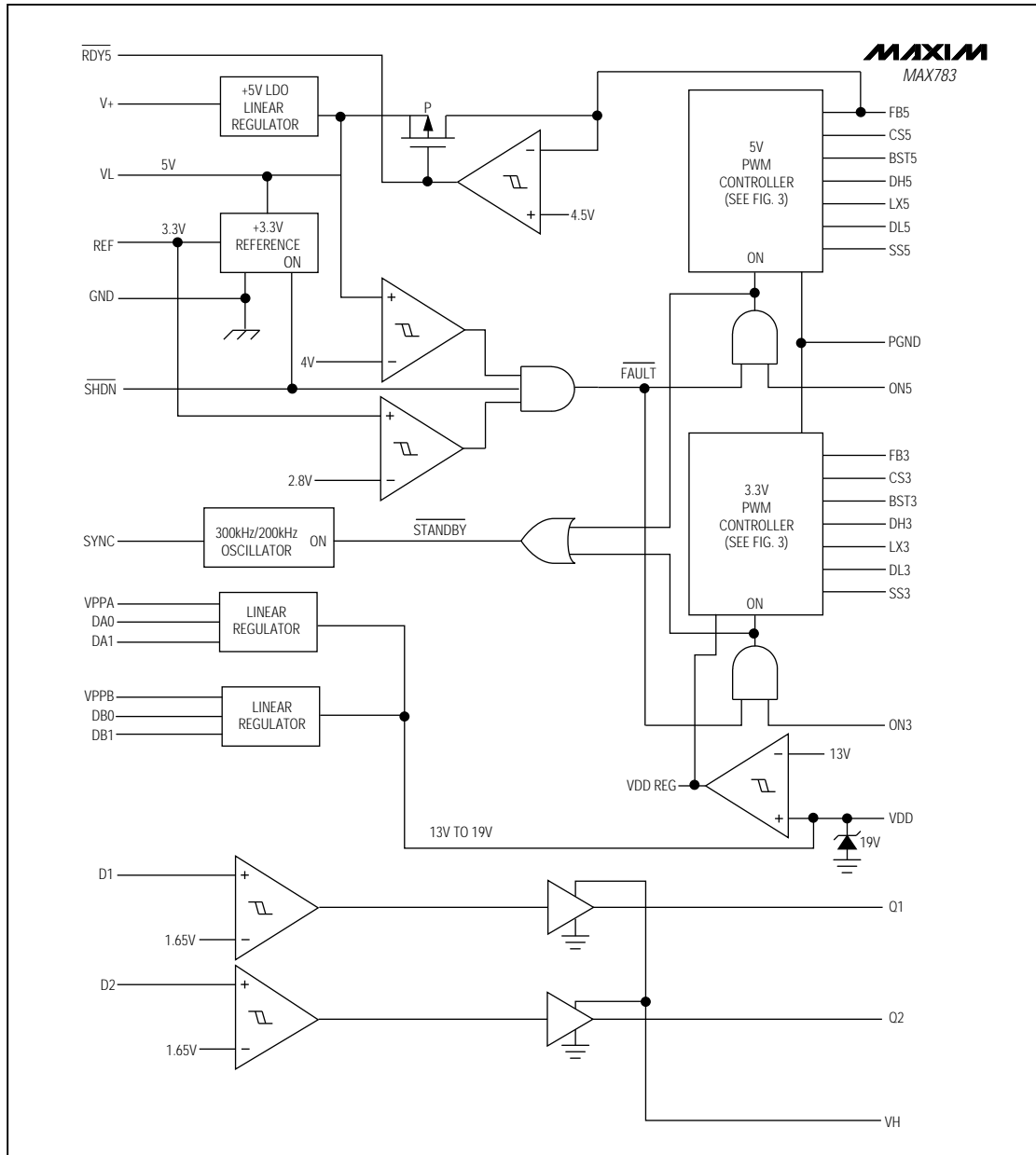

Figure 2. Block Diagram

Triple-Output Power-Supply Controller for Notebook Computers

Soft-Start/SS_ Inputs

Connecting capacitors to SS3 and SS5 allows gradual build-up of the +3.3V and +5V supplies after ON3 and ON5 are driven high. When ON3 or ON5 is low, the appropriate SS capacitors are discharged to GND. When ON3 or ON5 is driven high, a 4 μ A constant current source charges these capacitors up to 4V. The resulting ramp voltage on the SS_ pins linearly increases the current-limit comparator setpoint so as to increase the duty cycle to the external power MOSFETs up to the maximum output. With no SS capacitors, the circuit will reach maximum current limit within 10 μ s.

Soft-start greatly reduces initial in-rush current peaks and allows start-up time to be programmed externally.

Synchronous Rectifiers

Synchronous rectification allows for high efficiency by reducing the losses associated with the Schottky rectifiers. Also, the synchronous rectifier MOSFETs are necessary for correct operation of the MAX783's boost gate-drive and VDD supplies.

When the external high-side power MOSFET turns off, energy stored in the inductor causes its terminal voltage to reverse instantly. Current flows in the loop formed by the inductor, Schottky diode, and load—an action that charges up the filter capacitor. The Schottky diode has a forward voltage of about 0.5V which, although small, represents a significant power loss and degrades efficiency. A synchronous rectifier MOSFET parallels the diode and is turned on by DL3 (or DL5) shortly after the diode conducts. Since the on resistance ($r_{DS(ON)}$) of the synchronous rectifier is very low, the losses are reduced.

The synchronous rectifier MOSFET is turned off when the inductor current falls to zero.

Cross conduction (or "shoot-through") occurs if the high-side switch turns on at the same time as the synchronous rectifier. Internal break-before-make timing ensures that shoot-through does not occur. The Schottky rectifier conducts during the time that neither MOSFET is on, which improves efficiency by preventing the synchronous-rectifier MOSFET's lossy body diode from conducting.

The synchronous rectifier works under all operating conditions, including discontinuous-conduction and idle-mode. The +3.3V synchronous rectifier also controls the 15V VDD voltage (see the *High-Side Supply (VDD)* section).

Boost Gate-Driver Supply

Gate-drive voltage for the high-side N-channel switch is generated with a flying-capacitor boost circuit as shown in Figure 4. The capacitor is alternately charged from the VL supply via the diode and placed in parallel with

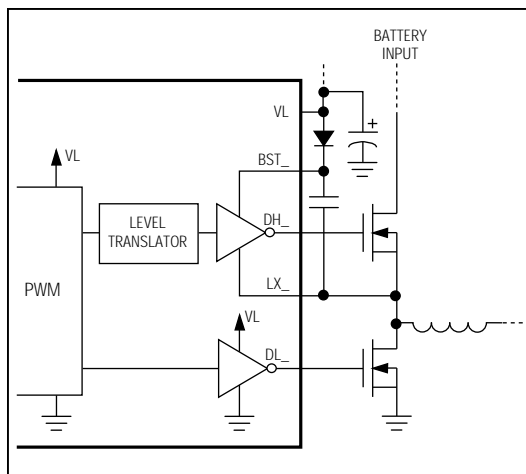

Figure 4. Boost Supply for Gate Drivers

the high-side MOSFET's gate-source terminals. On start-up, the synchronous rectifier (low-side) MOSFET forces LX_ to 0V and charges the BST_ capacitor to 5V. On the second half-cycle, the PWM turns on the high-side MOSFET by connecting the capacitor to the MOSFET gate by closing an internal switch between BST_ and DH_. This provides the necessary enhancement voltage to turn on the high-side switch, an action that "boosts" the 5V gate-drive signal above the battery voltage.

Ringings seen at the high-side MOSFET gates (DH3 and DH5) in discontinuous-conduction mode (light loads) is a natural operating condition caused by the residual energy in the tank circuit formed by the inductor and stray capacitance at the LX_ nodes. The gate driver negative rail is referred to LX_, so any ringing there is directly coupled to the gate-drive supply.

Modes of Operation

PWM Mode

Under heavy loads—over approximately 25% of full load—the +3.3V and +5V supplies operate as continuous-current PWM supplies (see *Typical Operating Characteristics*). The duty cycle (%ON) is approximately:

$$\%ON = V_{OUT}/V_{IN}$$

Current flows continuously in the inductor: First, it ramps up when the power MOSFET conducts; then, it ramps down during the flyback portion of each cycle as energy is put into the inductor and then discharged into the load. Note that the current flowing into the inductor when it is being charged is also flowing into the load, so the load is

Triple-Output Power-Supply Controller for Notebook Computers

MAX783

continuously receiving current from the inductor. This minimizes output ripple and maximizes inductor use, allowing very small physical and electrical sizes. Output ripple is primarily a function of the filter capacitor effective series resistance (ESR) and is typically under 50mV (see the *Design Procedure* section). Output ripple is worst at light load and maximum input voltage.

Idle Mode

Under light loads (<25% of full load), efficiency is further enhanced by turning the drive voltage on and off for only a single clock period, skipping most of the clock pulses entirely. Asynchronous switching, seen as “ghosting” on an oscilloscope, is thus a normal operating condition whenever the load current is less than approximately 25% of full load.

At certain input voltage and load conditions, a transition region exists where the controller can pass back and forth from idle-mode to PWM mode. In this situation, short bursts of pulses occur that make the current waveform look erratic, but do not materially affect the output ripple. Efficiency remains high.

Current Limiting

The voltage between CS3 (CS5) and FB3 (FB5) is continuously monitored. An external, low-value shunt resistor is connected between these pins, in series with the inductor, allowing the inductor current to be continuously measured throughout the switching cycle. Whenever this voltage exceeds 100mV, the drive voltage to the external high-side MOSFET is cut off. This protects the MOSFET, the load, and the battery in case of short circuits or temporary load surges. The current-limiting resistor R1 (R2) is typically 25m Ω (20m Ω) for a 3A load current.

Oscillator Frequency; SYNC Input

The SYNC input controls the oscillator frequency. Connecting SYNC to GND or to VL selects 200kHz operation; connecting to REF selects 300kHz operation. SYNC can also be driven with an external 240kHz to 350kHz CMOS/TTL source to synchronize the internal oscillator.

300kHz operation is used to minimize the inductor and filter capacitor sizes, but 200kHz may be necessary for low input voltages (see *Low-Voltage Operation*).

High-Side Supply (VDD)

The 15V VDD supply is obtained from the rectified and filtered secondary of transformer L2. VDD is enabled whenever the +3.3V supply is on (ON3 = high). The primary and secondary of L2 are connected so that, during the flyback (discharge) portion of each cycle, energy stored in the core is transferred into the +3.3V load through the primary and into VDD through the sec-

ondary, as determined by the turns ratio. The secondary voltage is added to the +3.3V to make VDD. See the *Typical Operating Characteristics* for the VDD supply's load capability.

Unlike other coupled-inductor flyback converters, the VDD voltage is regulated regardless of the loading on the +3.3V output. (Most coupled-inductor converters can only support the auxiliary output when the main output is loaded.) When the +3.3V supply is lightly loaded, the circuit achieves good control of VDD by pulsing the MOSFET normally used as the synchronous rectifier. This draws energy from the +3.3V supply's output capacitor and uses the transformer in a forward-converter mode (i.e., the +15V output takes energy out of the secondary when current is flowing in the primary). These forward-converter pulses are interspersed with normal synchronous-rectifier pulses, and they only occur at light loads on the +3.3V rail.

The transformer secondary's rectified and filtered output is only roughly regulated, and may be between 13V and 19V. It is brought back into VDD, which is also the feedback input, and used as the source for the PCMCIA VPP regulators. It can also be used as the VH power supply for the comparators or any external MOSFET drivers.

When the input voltage is above 12V, or when the +3.3V supply is heavily loaded and VDD is lightly loaded, L2's interwinding capacitance and leakage inductance can produce voltages above that calculated from the turns ratio. A 2.5mA shunt regulator limits VDD to 19V. If the battery voltage can rise above 12V, VDD must either be externally clamped with an 18V zener diode, or there must be a 1mA minimum load on VDD (or VPPA/VPPB).

Clock-frequency noise on the VDD rail of up to 3V_{p-p} is a facet of normal operation, and can be reduced by adding more output capacitance.

PCMCIA-Compatible, Programmable VPP Supplies

Two independent linear regulators furnish PCMCIA VPP supplies. The VPPA and VPPB outputs can be programmed to deliver 0V, 3.3V, 5V, or 12V. The 0V output mode has a 250 Ω pull-down to discharge external filter capacitors and ensure that flash EPROMs cannot be accidentally programmed. These linear regulators draw their power from the high-side supply (VDD), and each can furnish up to 60mA. Bypass VPPA and VPPB to GND with at least 1 μ F, with the bypass capacitors less than 20mm from the VPP pins.

The outputs are programmed with DA0, DA1, DB0 and DB1, as shown in Table 2.

Triple-Output Power-Supply Controller for Notebook Computers

Table 2. VPP Program Codes

DA0	DA1	VPPA
0	0	0V
0	1	5V
1	0	12V
1	1	3.3V

DB0	DB1	VPPB
0	0	0V
0	1	5V
1	0	12V
1	1	3.3V

These codes are compatible with many popular PCMCIA digital controllers such as the Intel 82365SL. For other interfaces, one of the inputs can be permanently wired high or low and the other toggled to turn the supply on and off. The truth table shows that either a "0" or "1" can be used to turn each supply on. The two VPP outputs can be safely connected in parallel for increased load capability if the control inputs are also tied together (i.e., DA0 to DB0, DA1 to DB1). If VPAA and VPPB are connected in parallel, some devices may exhibit several milliamps of increased quiescent supply current when enabled, due to slightly mismatched output voltage set points.

Comparators

Two noninverting comparators can be used as precision voltage comparators or high-side drivers. The supply for these comparators (VH) is brought out and may be connected to any voltage between +3V and +19V. The noninverting inputs (D1-D2) are high impedance, and the inverting input is internally connected to a 1.650V reference. Each output (Q1-Q2) sources 20 μ A from VH when its input is above 1.650V, and sinks 500 μ A to GND when its input is below 1.650V. The Q1-Q2 outputs can be fixed together in wired-OR configuration since the pull-up current is only 20 μ A.

Connecting VH to a logic supply (5V or 3V) allows the comparators to be used as low-battery detectors. For driving N-channel power MOSFETs to turn external loads on and off, VH should be 6V to 12V higher than the load voltage. This enables the MOSFETs to be fully turned on and results in low $r_{DS(ON)}$. VDD is a convenient source for VH.

Internal VREF and VL Supplies

An internal linear regulator produces the 5V used by the internal control circuits. This regulator's output is available on pin VL and can source 5mA for external loads. Bypass VL to GND with 4.7 μ F. To save power, when the +5V switch-mode supply is above 4.5V, the VL linear regulator is turned off and the high-efficiency +5V switch-mode supply output is internally connected to VL.

The 3.3V precision reference (REF) is powered from the internal 5V VL supply. It can furnish up to 5mA for external loads. Bypass REF to GND with 0.22 μ F, plus 1 μ F/mA of load current. The main switch-mode outputs track the reference voltage. Loading the reference reduces the main output voltages slightly, according to the reference voltage load regulation error.

Both the VL and REF supplies can remain active—even when the switch-mode regulators are turned off—to supply memory keep-alive power (see *Shutdown Mode* section).

These linear regulator outputs can be directly connected to the corresponding switch-mode regulator outputs (i.e., REF to +3.3V, VL to +5V) to hold up the main supplies in standby mode. However, to ensure start-up, standby load currents must not exceed 5mA on each supply.

Shutdown Mode

Shutdown ($\overline{\text{SHDN}} = \text{low}$) forces both PWMs off and disables the REF output and the auxiliary comparators including RDY5. Supply current in shutdown mode is typically 25 μ A. The VL supply remains active and can source 25mA for external loads. VL load capability is higher in shutdown and standby modes than when the PWMs are operating (25mA vs. 5mA).

Standby mode is achieved by holding ON3 and ON5 low while $\overline{\text{SHDN}}$ is high. This disables both PWMs, but keeps VL, REF, and the precision comparators alive. Supply current in standby mode is typically 70 μ A.

Other ways to shut down the MAX783 are suggested in the applications section of the MAX782 data sheet.

Design Procedure

Figure 1's predesigned application circuit contains the correct component values for 3A output currents and a 6V to 20V input range. Use the design procedure that follows to optimize this basic schematic for different voltage or current requirements.

Before beginning a design, firmly establish the following:

$V_{IN(MAX)}$, the maximum input (battery) voltage. This value should include the worst-case conditions under which the power supply is expected to function, such as no-load (standby) operation when a battery charger is connected but no battery is installed. $V_{IN(MAX)}$ cannot exceed 30V.

$V_{IN(MIN)}$, the minimum input (battery) voltage. This value should be taken at the full-load operating current under the lowest battery conditions. If $V_{IN(MIN)}$ is below about 6V, the filter capacitance required to maintain good AC load regulation increases, and the current limit for the +5V supply has to be increased for the same load level.

Triple-Output Power-Supply Controller for Notebook Computers

MAX783

+5V Inductor (L1)

Three inductor parameters are required: the inductance value (L), the peak inductor current (I_{LPEAK}), and the coil resistance (R_L). The inductance is:

$$L = \frac{(V_{OUT}) (V_{IN(MAX)} - V_{OUT})}{(V_{IN(MAX)}) (f) (I_{OUT}) (LIR)}$$

where: V_{OUT} = output voltage, 5V
 $V_{IN(MAX)}$ = maximum input voltage (V)
 f = switching frequency, normally 300kHz
 I_{OUT} = maximum +5V DC load current (A)
 LIR = ratio of inductor peak-to-peak AC current to average DC load current, typically 0.3.

A higher value of LIR allows smaller inductance, but results in higher losses and higher ripple.

The highest peak inductor current (I_{LPEAK}) equals the DC load current (I_{OUT}) plus half the peak-to-peak AC inductor current (I_{LPP}). The peak-to-peak AC inductor current is typically chosen as 30% of the maximum DC load current, so the peak inductor current is 1.15 times I_{OUT} .

The peak inductor current at full load is given by:

$$I_{LPEAK} = I_{OUT} + \frac{(V_{OUT}) (V_{IN(MAX)} - V_{OUT})}{(2) (f) (L) (V_{IN(MAX)})}$$

The coil resistance should be as low as possible, preferably in the low milliohms. The coil is effectively in series with the load at all times, so the wire losses alone are approximately:

$$\text{Power loss} = (I_{OUT})^2 (R_L)$$

In general, select a standard inductor that meets the L, I_{LPEAK} , and R_L requirements (see Tables 3 and 4). If a standard inductor is unavailable, choose a core with an LI^2 parameter greater than $(L)(I_{LPEAK})^2$, and use the largest wire that will fit the core.

+3.3V Transformer (L2)

Table 3 lists two commercially available transformers and parts for a custom transformer. The following instructions show how to determine the transformer parameters required for a custom design:

- L_p , the primary inductance value
- I_{LPEAK} , the peak primary current
- LI^2 , the core's energy rating
- R_p and R_s , the primary and secondary resistances
- N, the primary-to-secondary turns ratio.

The transformer primary is specified just as the +5V inductor, using $V_{OUT} = +3.3V$; but the secondary output (VDD) power must be added in as if it were part of the

primary. VDD current (I_{DD}) usually includes the VPPA and VPPB output currents. The total +3.3V power, P_{TOTAL} , is the sum of these powers:

$$P_{TOTAL} = P_3 + P_{DD}$$

where: $P_3 = (V_{OUT}) (I_{OUT})$;
 $P_{DD} = (VDD) (I_{DD})$;

and: V_{OUT} = output voltage, 3.3V;
 I_{OUT} = maximum +3.3V load current (A);
 VDD = VDD output voltage, 15V;
 I_{DD} = maximum VDD load current (A);

so: $P_{TOTAL} = (3.3V \times I_{OUT}) + (15V \times I_{DD})$
and the equivalent +3.3V output current, I_{TOTAL} , is:
 $I_{TOTAL} = P_{TOTAL} / 3.3V$
 $= [(3.3V \times I_{OUT}) + (15V \times I_{DD})] / 3.3V$.

The primary inductance, L_p , is given by:

$$L_p = \frac{(V_{OUT}) (V_{IN(MAX)} - V_{OUT})}{(V_{IN(MAX)}) (f) (I_{TOTAL}) (LIR)}$$

where: $V_{IN(MAX)}$ = maximum input voltage
 f = switching frequency, normally 300kHz
 I_{TOTAL} = maximum equivalent load current (A)
 LIR = ratio of primary peak-to-peak AC current to average DC load current, typically 0.3.

The highest peak primary current (I_{LPEAK}) equals the total DC load current (I_{TOTAL}) plus half the peak-to-peak AC primary current (I_{LPP}). The peak-to-peak AC primary current is typically chosen as 30% of the maximum DC load current, so the peak primary current is 1.15 times I_{TOTAL} . A higher value of LIR allows smaller inductance, but results in higher losses and higher ripple.

The peak current in the primary at full load is given by:

$$I_{LPEAK} = I_{TOTAL} + \frac{(V_{OUT}) (V_{IN(MAX)} - V_{OUT})}{(2) (f) (L_p) (V_{IN(MAX)})}$$

Choose a core with an LI^2 parameter greater than $(L_p) (I_{LPEAK})^2$.

The winding resistances, R_p and R_s , should be as low as possible, preferably in the low milliohms. Use the largest gauge wire that will fit on the core. The coil is effectively in series with the load at all times, so the resistive losses in the primary winding alone are approximately $(I_{TOTAL})^2 (R_p)$.

The minimum turns ratio, N_{MIN} , is 3.3V:(15V-3.3V). Use 1:4 to accommodate the tolerance of the +3.3V supply. A greater ratio will reduce efficiency of the VPP regulators.

Minimize the diode capacitance and the interwinding capacitance, since they create losses through the VDD shunt regulator. These are most significant when the input voltage is high, the +3.3V load is heavy, and there is no load on VDD.

Triple-Output Power-Supply Controller for Notebook Computers

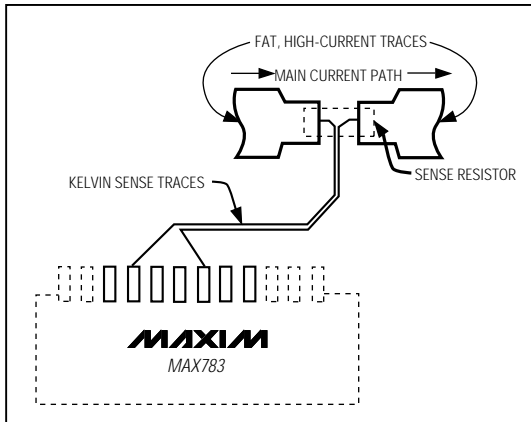

Figure 5. Kelvin Connections for the Current-Sense Resistors

Ensure the transformer secondary is connected with the right polarity: A VDD supply will be generated with either polarity, but proper operation is possible only with the correct polarity. Test for correct connection by observing the phase relationship between the LX3 switching node and the transformer secondary under load. The two waveforms must be 180° out of phase.

Current-Sense Resistors (R1, R2)

The sense resistors must carry the peak current in the inductor, which exceeds the full DC load current. The internal current limiting starts when the voltage across the sense resistors exceeds 100mV nominally, 80mV minimum. Use the minimum value to ensure adequate output current capability: For the +5V supply, $R1 = 80\text{mV} / (1.15 \times I_{\text{OUT}})$; for the +3.3V supply, $R2 = 80\text{mV} / (1.15 \times I_{\text{TOTAL}})$, assuming that LIR = 0.3.

Since the sense resistance values (e.g., $R1 = 25\text{m}\Omega$ for $I_{\text{OUT}} = 3\text{A}$) are similar to a few centimeters of narrow traces on a printed circuit board, trace resistance can contribute significant errors. To prevent this, Kelvin connect the CS_ and FB_ pins to the sense resistors; use separate traces not carrying any of the inductor or load current, as shown in Figure 5. Run these traces parallel at minimum spacing from one another. The wiring layout for these traces is critical for stable, low-ripple outputs (see the *Layout and Grounding* section).

MOSFET Switches (N1-N4)

The four N-channel power MOSFETs are usually identical and must be "logic-level" FETs; that is, they must be fully on (have low $r_{\text{DS(ON)}}$) with only 4V gate-source drive voltage. The MOSFET $r_{\text{DS(ON)}}$ should ideally be

about twice the value of the sense resistor. MOSFETs with even lower $r_{\text{DS(ON)}}$ have higher gate capacitance, which increases switching time and transition losses.

MOSFETs with low gate-threshold voltage specifications (i.e., maximum $V_{\text{GS(TH)}} = 2\text{V}$ rather than 3V) are preferred, especially for high-current (5A) applications.

Output Filter Capacitors (C3-C6)

The output filter capacitors determine the loop stability and output ripple voltage. To ensure stability, the minimum capacitance and maximum ESR values are:

$$C_F > \frac{V_{\text{REF}}}{(V_{\text{OUT}}) (R_{\text{CS}}) (2) (\pi) (\text{GBWP})}$$

and,

$$\text{ESR}_{\text{CF}} < \frac{(V_{\text{OUT}}) (R_{\text{CS}})}{V_{\text{REF}}}$$

where: C_F = output filter capacitance, C6 or C7 (F)
 V_{REF} = reference voltage, 3.3V
 V_{OUT} = output voltage, 3.3V or 5V
 R_{CS} = sense resistor (Ω)
 GBWP = gain-bandwidth product, 60kHz
 ESR_{CF} = output filter capacitor ESR (Ω).

Be sure to select output capacitors that satisfy **both** the minimum capacitance and maximum ESR requirements. To achieve the low ESR required, it may be appropriate to use a capacitance value 2 or 3 times larger than the calculated minimum.

The output ripple in continuous-current mode is:

$$V_{\text{OUT(RPL)}} = (I_{\text{LPP(MAX)}}) [(\text{ESR}_{\text{CF}} + 1 / (2 \times \pi \times f \times C_F))].$$

In idle-mode, the ripple has a capacitive and resistive component:

$$V_{\text{OUT(RPL)(C)}} = \frac{(4 \times 10^{-4}) (L)}{(R_{\text{CS}}^2) (C_F)} \times \left(\frac{1}{V_{\text{OUT}}} + \frac{1}{V_{\text{IN}} - V_{\text{OUT}}} \right) \text{Volts}$$

$$V_{\text{OUT(RPL)(R)}} = \frac{(0.02) (\text{ESR}_{\text{CF}})}{R_{\text{CS}}} \text{Volts}$$

The total ripple, $V_{\text{OUT(RPL)}}$, can be approximated as follows:

$$\text{if } V_{\text{OUT(RPL)(R)}} < 0.5 V_{\text{OUT(RPL)(C)},}$$

$$\text{then } V_{\text{OUT(RPL)}} = V_{\text{OUT(RPL)(C)},}$$

$$\text{otherwise, } V_{\text{OUT(RPL)}} = 0.5 V_{\text{OUT(RPL)(C)}} + V_{\text{OUT(RPL)(R)}}.$$

Triple-Output Power-Supply Controller for Notebook Computers

Diode D3

The voltage rating of D3 should be at least $4 \times V_{IN} + 5V$ plus a safety margin. A rating of at least 100V is necessary for the maximum 20V supply. Use a high-speed silicon diode (with a higher breakdown voltage and low capacitance) rather than a Schottky diode. D3's current rating should exceed twice the maximum current load on VDD.

Diodes D2 and D5

Use 1N5819s or similar Schottky diodes. D2 and D5 conduct only about 3% of the time, so the 1N5819's 1A current rating is conservative. The voltage rating of D2 and D5 must exceed the maximum input supply voltage from the battery. These diodes must be Schottky diodes to prevent the lossy MOSFET body diodes from turning on, and they must be placed physically close to their associated synchronous rectifier MOSFETs.

Soft-Start Capacitors (C13, C14)

A capacitor connected from GND to either SS pin causes that supply to ramp up slowly. The ramp time to full current limit, t_{SS} , is approximately 1ms for every nF of capacitance on SS₋, with a minimum value of 10 μ s. Typical capacitor values are in the 10nF to 100nF range.

Because this ramp is applied to the current-limit circuit, the actual time for the output voltage to ramp up depends on the load current and output capacitor value. Using Figure 1's circuit with a 2A load and no SS capacitor, full output voltage is reached in less than 1ms after ON₋ is driven high.

Bypass Capacitors

Input Filter Capacitors (C1, C2)

Use at least 3 μ F/W of output power for the input filter capacitors, C1 and C2. They should have less than 150m Ω ESR, and should be located no further than 10mm from N1 and N2 to prevent ringing. Connect the negative terminals directly to PGND. Be careful not to exceed the surge current ratings of the bypass capacitors. If the battery pack or AC adapter has very low output impedance, tantalum capacitors may be damaged when initial connection is made. In this situation, electrolytic capacitors such as Sanyo OS-CON may be necessary. Also, take care that the RMS input current

of the MAX783 circuit does not exceed the bypass capacitor ripple current rating. The RMS input current (I_{RMS}) can be calculated as shown below:

$$I_{RMS} = \text{RMS AC input current} \\ = I_{LOAD} \left(\frac{\sqrt{V_{OUT} (V_{IN} - V_{OUT})}}{V_{IN}} \right)$$

Low-Voltage Operation

Low input voltages, such as the 6V end-of-life voltage of a 6-cell NiCd battery, place extra demands on the +5V buck regulator because of the very low input-output differential voltage. The standard application circuit works well with supply voltages down to 6V; at input voltages less than 6V, the +5V filter capacitor values must be increased. If the minimum battery voltage is 6.5V or higher, the 660 μ F total 5V filter capacitance can be reduced to 330 μ F.

The +5V supply's load-transient response is impaired due to reduced inductor-current slew rate, which is in turn caused by reduced voltage applied across the buck inductor during the high-side switch-on time. So, the +5V output sags when hit with an abrupt load current change, unless the +5V filter capacitor value is increased. Only the capacitance is affected and ESR requirements don't change. Therefore, the added capacitance can be supplied by an additional low-cost bulk capacitor in parallel with the normal low-ESR switching-regulator capacitor. The equation for voltage sag under a step-load change follows:

$$V_{SAG} = \frac{(I_{STEP})^2(L)}{(2)(C_F)(V_{IN(MIN)} \times D_{MAX} - V_{OUT})}$$

where D_{MAX} is the maximum duty cycle. Higher duty cycles are possible when the oscillator frequency is reduced to 200kHz, due to fixed propagation delays through the PWM comparator becoming a lesser part of the whole period. The tested worst-case limit for D_{MAX} is 92% at 200kHz. Lower inductance values can reduce the filter capacitance requirement, but only at the expense of increased noise at high input voltages (resulting from higher peak currents).

Triple-Output Power-Supply Controller for Notebook Computers

Layout and Grounding

Good layout is necessary to achieve the designed output power, high efficiency, and low noise. Good layout includes use of a ground plane, appropriate component placement, and correct routing of traces using appropriate trace widths. The following points are in order of importance:

1. A ground plane is essential for optimum performance. In most applications, the power supply is located on a multilayer motherboard, and full use of the four or more copper layers is recommended. Use the top and bottom layers for interconnections, and the inner layers for an uninterrupted ground plane.
2. Keep the Kelvin-connected current-sense traces short, close together, and away from switching nodes. See Figure 5. Important: Place the current-sense resistors close to the IC (less than 10mm away if possible).
3. Place the LX node components N1, N2, D2, and L1 as close together as possible. This reduces resistive and switching losses and keeps noise due to ground inductance confined. Do the same with the other LX node components N3, N4, D5, and L2.
4. The input filter capacitor C1 should be less than 10mm away from N1's drain. The connecting copper trace carries large currents and must be at least 2mm wide, preferably 5mm.

Similarly, place C2 close to N3's drain, and connect them with a wide trace.

5. Keep the gate connections to the MOSFETs short for low inductance (less than 20mm long and more than 0.5mm wide) to ensure clean switching.
6. To achieve good shielding, it is best to keep all high-voltage switching signals (MOSFET gate drives DH3 and DH5, BST3 and BST5, and the two LX nodes) on one side of the board and all sensitive nodes (CS3, CS5, FB3, FB5 and REF) on the other side.
7. Connect the GND and PGND pins directly to the ground plane, which should ideally be an inner layer of a multilayer board.
8. Connect the bypass capacitor C7 very close (less than 10mm) to the VL pin.
9. Minimize the capacitance at the transformer secondary. Place D3 and C12 very close to each other and to the secondary, then route the output to the IC's VDD pin with a short trace. Bypass with 0.1 μ F close to the VDD pin if this trace is longer than 50mm.

The layout for the evaluation board is shown in the *Evaluation Kit* section. It provides an effective, low-noise, high-efficiency example.

Triple-Output Power-Supply Controller for Notebook Computers

MAX783

Table 3. Surface-Mount Components

(See Figure 1 for schematic and Table 4 for manufacturers' telephone numbers.)

COMPONENT	TYPE	MANUFACTURER	PART NUMBER
C1, C2	33 μ F, 35V tantalum	Sprague	595D336X0035R2B
	33 μ F, 25V tantalum	AVX	TPSE336M025R0300
C3, C4	330 μ F, 10V tantalum	Sprague	595DD337X0010R2B
	330 μ F, 6.3V tantalum	AVX	TPSE337M006R0100
C5, C6	150 μ F, 10V tantalum	Sprague	595D157X0010D2B
	220 μ F, 10V tantalum	AVX	TPSE227M010R0100
C7	4.7 μ F 16V tantalum	Sprague	595D475X0016A
C8, C9, C15	1 μ F, 20V tantalum	Sprague	595D105X0020T
C10, C11	0.1 μ F, 16V tantalum	Murata-Erie	GRM42-6X7R104K50V
C12	2.2 μ F, 25V tantalum	Sprague	595D225X0025B
C13, C14	0.01 μ F, ceramic	Murata-Erie	GRM42-6X7R103K50V
D1	Dual low-power Schottky	Central Semiconductor	CMP5H-3A
D3	Fast silicon rectifier	Nihon	EC11FS1
D2, D5	1N5819 Schottky	Nihon	EC10QS04
D6	18V, 100mW zener diode	Central Semiconductor	CMPZ5248
R1	0.025 Ω SMT resistor	IRC	LR2010-01-R025-F
R2	0.02 Ω SMT resistor	IRC	LR2010-01-R020-F
N1-N4	N-channel MOSFETs	International Rectifier	IRF7101 (Note 1)
L1	10 μ H, 2.5A inductor	Sumida	CDR125-100
L2	10 μ H, 1:4 transformer (Note 2)	Transpower	TTI5897 (for 3.3V at 1A)
		Transpower	TTI5902 (for 3.3V at 3A)
		Coiltronics	CTX03-12210 (for 3.3V at 2A)

Note 1: Four IRF7101s total: each device has both sections connected in parallel.

Note 2: These transformers have different sizes and pinouts. The MAX783 EV kit has the correct pad layout for the TTI5902 transformer, but all the transformers listed can be wired in easily.

Table 4. Surface-Mount Component Suppliers

Company	Factory Fax [country code]	USA Phone
AVX	[1] 207-283-1941	(207) 282-5111 (800) 282-4975
Central Semi	[1] 516-435-1824	(516) 435-1110
Coiltronics	[1] 407-241-9339	(407) 241-7876
International Rectifier	[1] 310-322-3332	(310) 322-3331
IRC	[1] 512-992-3377	(512) 992-7900
Murata-Erie	[1] 404-736-3030	(404) 736-1300
Nihon	[81] 3-3494-7414	(805) 867-2555*
Sprague	[1] 508-339-5063	(508) 339-8900
Sumida	[81] 3-3607-5428	(708) 956-0666
Transpower Tech.	[1] 702-831-3521	(702) 831-0140

*Distributor

Triple-Output Power-Supply Controller for Notebook Computers

EV Kit Standard Features

- ◆ **Battery Range: 5.5V to 20V***
- ◆ **Load Capability: 5V at 3A***
3.3V at 3A*
12V at 120mA or
15V at 200mA
- ◆ **3.3V and 5V Keep-Alive Linear Regulator Outputs**
- ◆ **Dual PCMCIA VPP Outputs**
- ◆ **Oscillator Sync Input**

*For wider input voltage range or higher load current, see the *Design Procedure*.

EV Kit Description

The MAX783 evaluation kit (EV kit) is a preassembled and tested demonstration board that embodies the standard application circuit, with some extra pull-up and pull-down resistors needed to set default logic signal levels. The board comes configured to accept battery voltages between 5.5V and 20V, but it can be reconfigured for voltages between 5.5V and 30V. The maximum voltage for safe operation (20V) is determined by the breakdown voltage rating of the external MOSFETs and input filter capacitor (C1 and C2) voltage ratings; if these are replaced with high-voltage devices, the board can tolerate 30V input without damage (36V absolute max).

Load current capability of the standard board is 3A at each main output (5V and 3.3V) and 60mA at each 12V VPP output. Load current capability can also be configured by selecting appropriate external components and sense resistor values, with practical load capability up to 7A at each main output and 500mA on the 15V flyback output (see the *Design Procedure* for reconfiguring both load and input voltage capability). All functions are controlled by two on-board dipswitches, which can be overridden by external CMOS/TTL logic signals if desired (provided the dipswitches are set to off first).

See Table 3 for the EV kit components. These components correspond exactly to Figure 1's Standard Application Circuit, with the addition of the following chip resistors (which are required only to set default logic and supply levels). The comparator outputs both swing 0V to 5V unless R14 is removed and R12 is installed, in which case their output swing is 0V to 15V.

R3-R11 1M Ω 5% resistors (logic pull-down, usually not needed and not installed in normal applications)

Evaluation Kit Information

R12	Open-circuit (no resistor installed)
R13	100k Ω 5% chip resistor (SYNC pull-down, usually shorted out)
R14	560 Ω 5% resistor (pull-up for comparator supply, usually shorted out or left open)

EV Kit Quick Reference

Connect a stiff (30W or better) bench power supply to the +V_{IN} and GND pads found on the edge of the board. Turn up the input voltage to somewhere between 5V and 20V. Set switches SW2A, SW2B, and SW2C on (if they are not already on), taking the device out of shutdown and turning on the main switching regulators. Set switch SW2D off so that the oscillator is set to 200kHz, which is the appropriate frequency for the 6V-20V input range. The main outputs are now regulating and ready for heavy loads. For best output accuracy and noise characteristics, loads should be returned separately to the GND pad corresponding to and adjacent to each output (+3OUT and +5OUT). Normal full-load regulation error is typically -2.5% while keeping the outputs within tolerance. If the measured error is higher, there may be drops in the wiring or ground. Ensure the voltmeter is sensing directly at the output and ground pads.

To observe normal PWM switching action, place a 1A load on either output and observe the corresponding switching node (device LX_ pin) while varying the input voltage. Without a load, the switching waveforms are intermittent and difficult to trigger on and it may appear that the board isn't working (except for the presence of output voltage).

To exercise the VPP controls, first ensure the 3.3V switch-mode supply is ON. The loosely regulated flyback voltage (13V to 19V) will be present at the edge pad marked "+15OUT". Turn on each VPP output by setting the appropriate code on SW1, where ON = HIGH (see Table 1).

The 5V linear regulator output is always present, even in shutdown mode, and can be measured at the VL pad. If the battery is connected and VL is not at 5V or close to it, something is wrong (excess VL load, possibly). The precision 3.3V linear regulator (REF) is activated by taking the device out of shutdown mode (by turning SW2C on).

Turning on the SW2D sets the oscillator to 300kHz, but the external component values should be changed first (see the *Design Procedure*). The oscillator can be synchronized to an external clock signal by driving the SYNC pad with a 240kHz to 350kHz pulse train of 5V amplitude while SW2D is off.

Triple-Output Power-Supply Controller for Notebook Computers

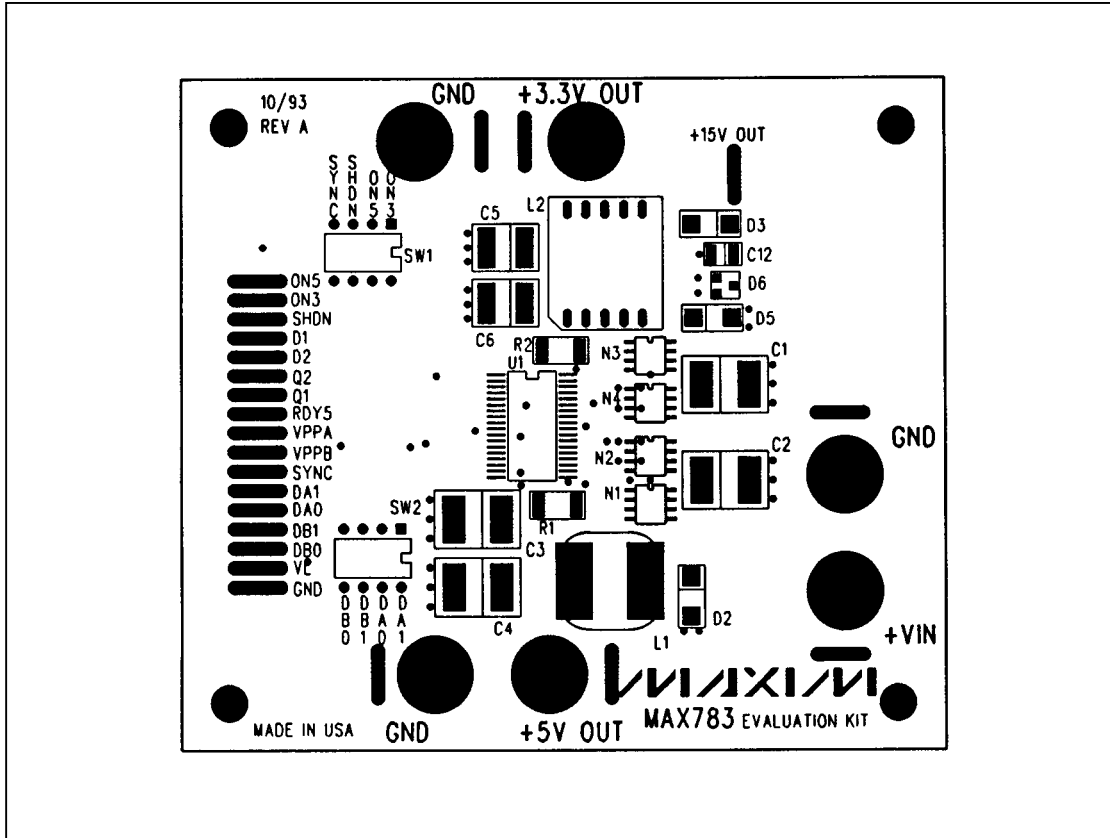

Figure 7. MAX783 EV Kit Top Component Layout and Silk Screen, Top View

Triple-Output Power-Supply Controller for Notebook Computers

MAX783

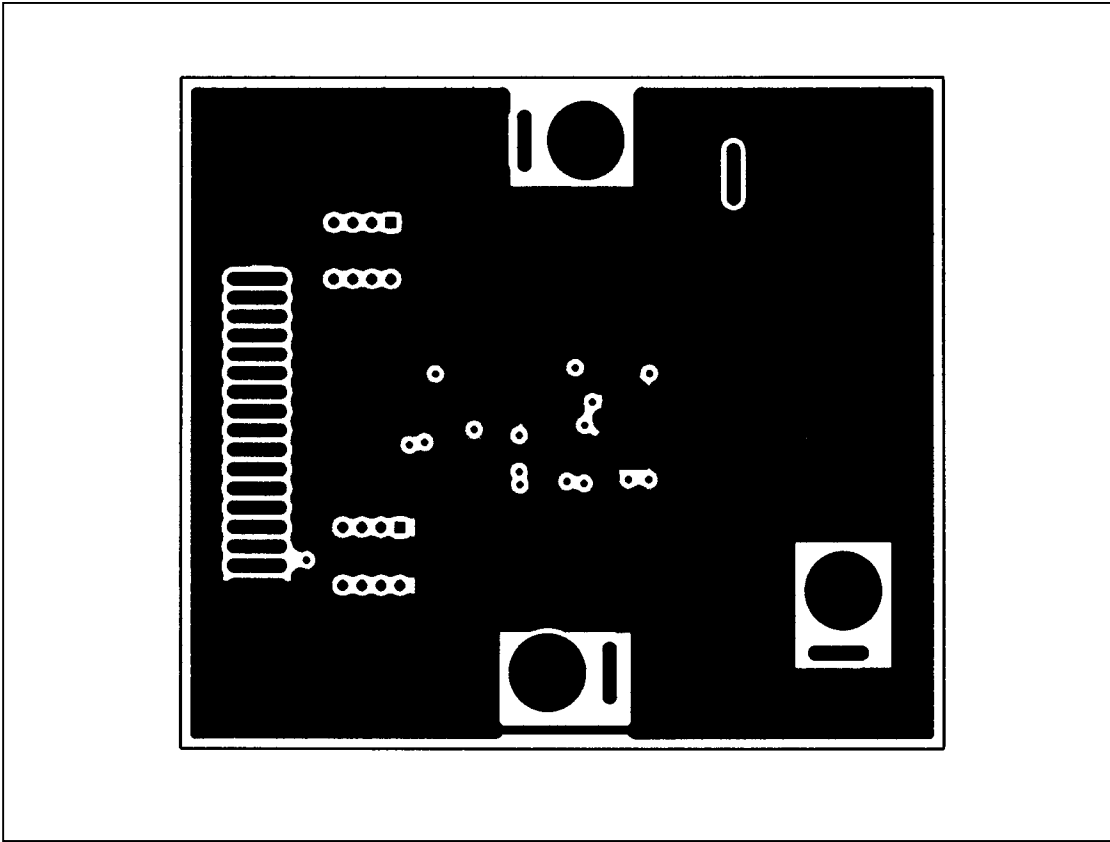

Figure 8. MAX783 EV Kit Ground Plane (Layers 2 and 3), Top View

Triple-Output Power-Supply Controller for Notebook Computers

MAX783

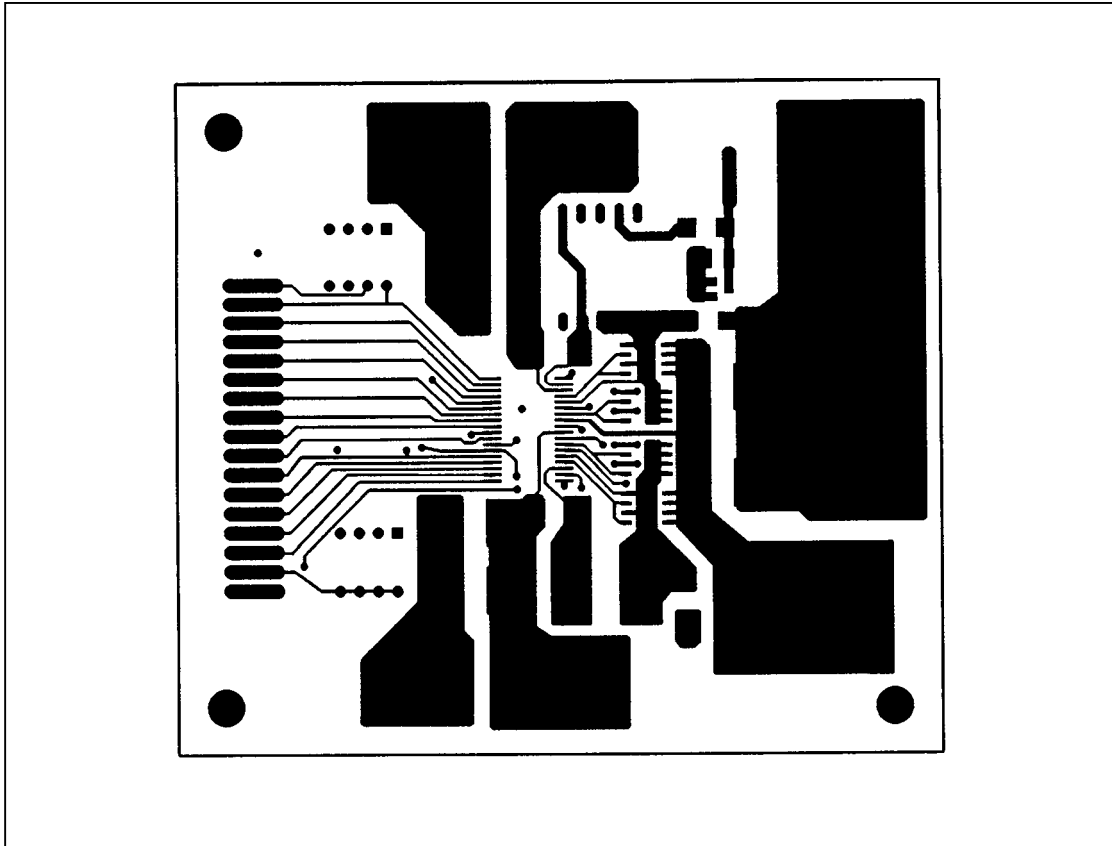

Figure 9. MAX783 EV Kit Top Layer (Layer 1), Top View

Triple-Output Power-Supply Controller for Notebook Computers

MAX783

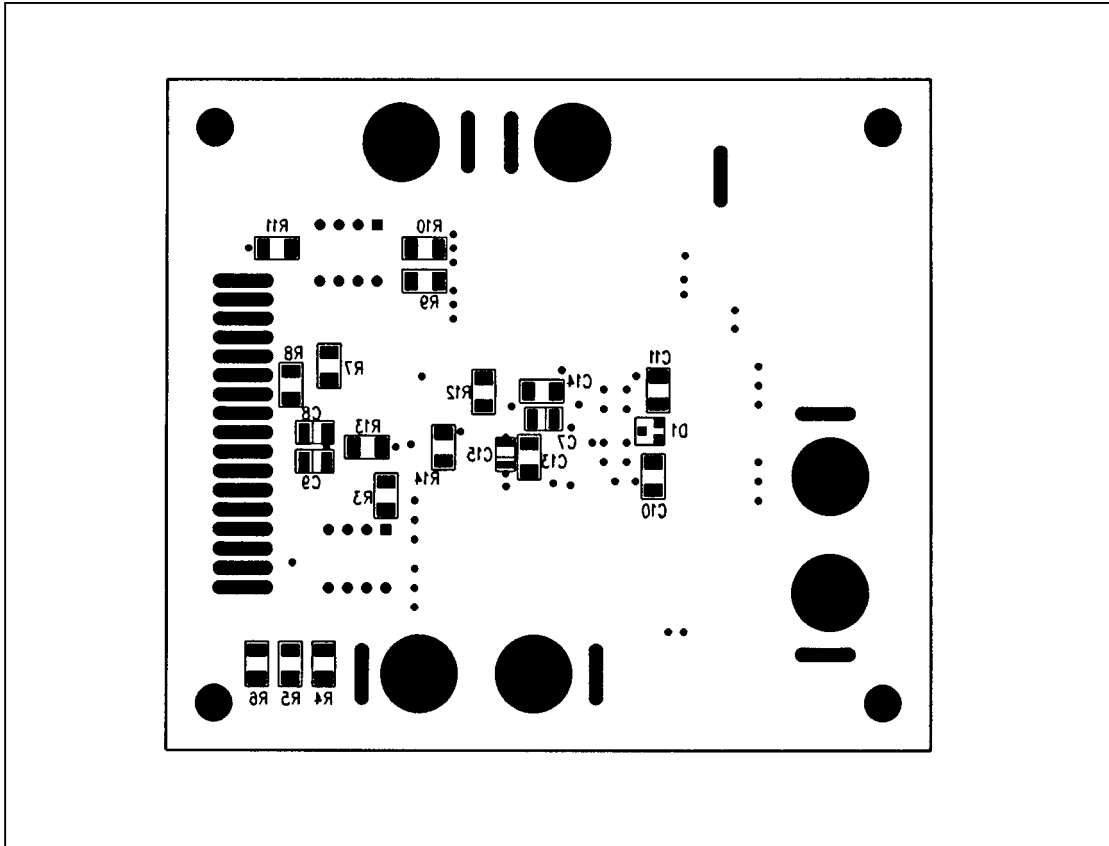

Figure 10. MAX783 EV Kit, Bottom Component Layout and Silk Screen, Bottom View

Triple-Output Power-Supply Controller for Notebook Computers

MAX783

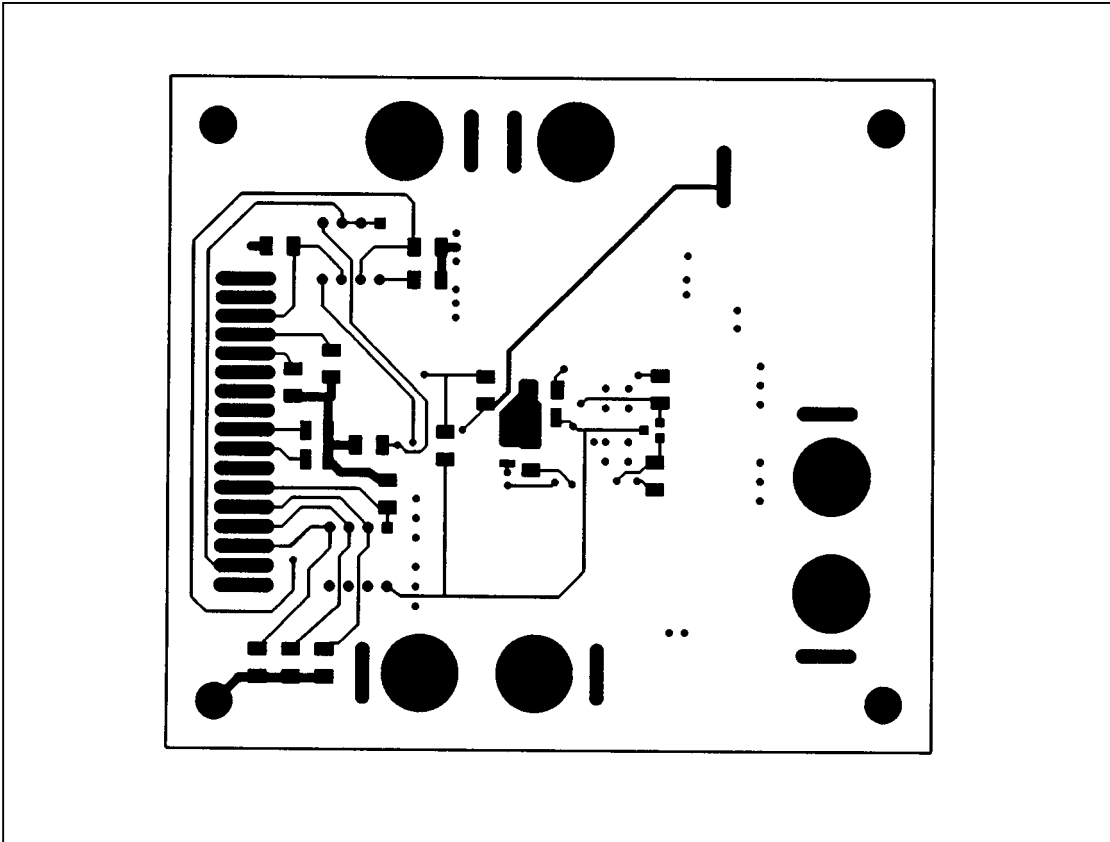

Figure 11. MAX783 EV Kit, Bottom Layer (Layer 4), Top View

Triple-Output Power-Supply Controller for Notebook Computers

MAX783

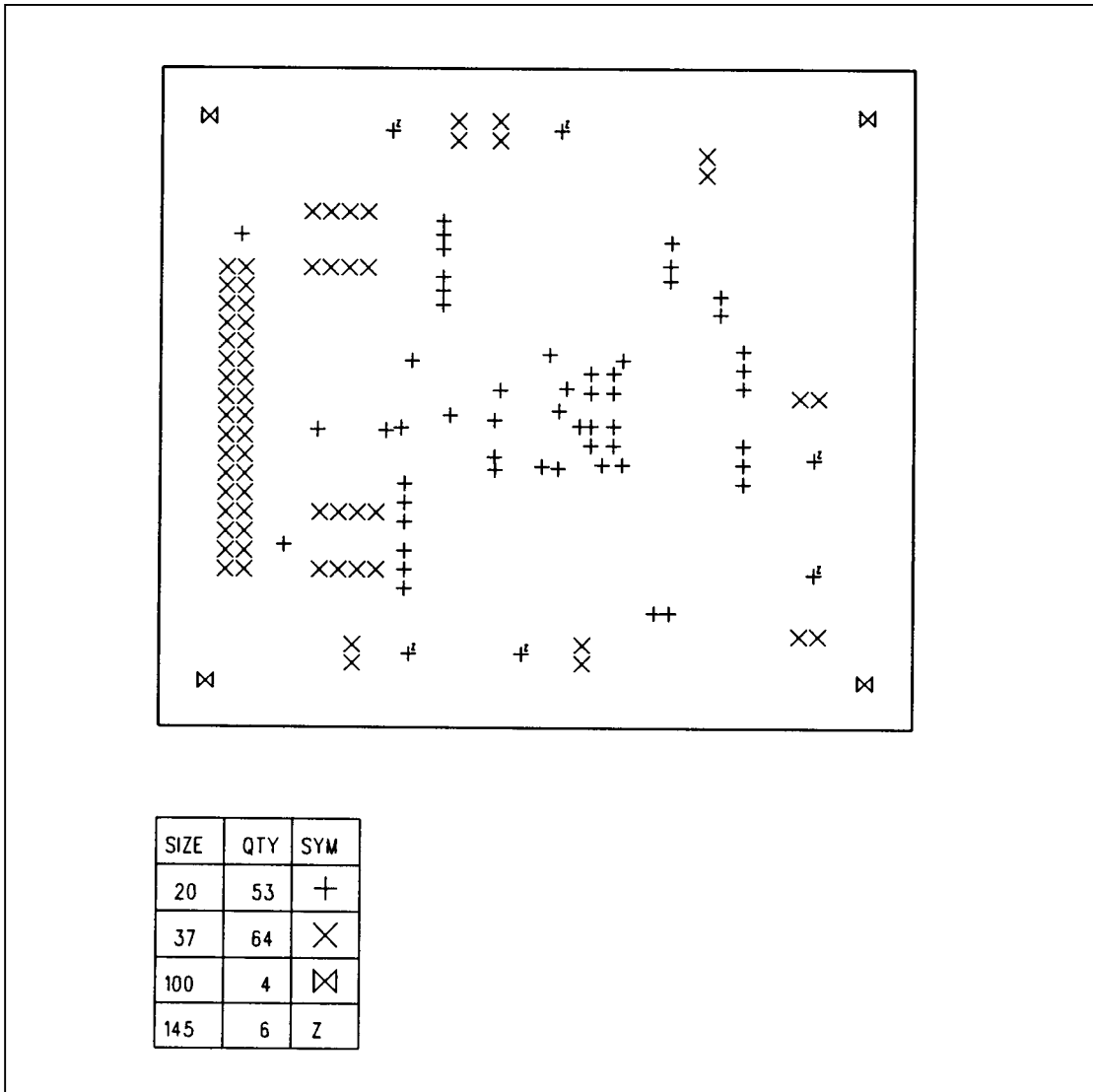
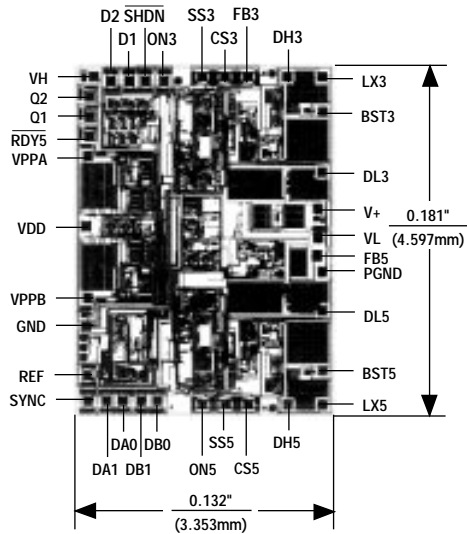

Figure 12. MAX783 EV Kit, Drill Schedule

MAX783

Triple-Output Power-Supply Controller for Notebook Computers

Chip Topography



TRANSISTOR COUNT: 1569
SUBSTRATE CONNECTED TO GND

Ordering Information (continued)

PART	TEMP. RANGE	PIN-PACKAGE	V _{OUT}
MAX783SCBX	0°C to +70°C	36 SSOP	3.6V
MAX783C/D	0°C to +70°C	Dice*	—
MAX783EBX	-40°C to +85°C	36 SSOP	3.3V
MAX783REBX	-40°C to +85°C	36 SSOP	3.45V
MAX783SEBX	-40°C to +85°C	36 SSOP	3.6V

EV KIT	TEMP. RANGE	BOARD TYPE
MAX783EVKIT-SO	0°C to +70°C	Surface Mount

* Dice are specified at +25°C only.

Package Information

DIM	INCHES		MILLIMETERS	
	MIN	MAX	MIN	MAX
A	0.094	0.104	2.39	2.64
A1	0.004	0.011	0.10	0.28
B	0.011	0.017	0.30	0.44
C	0.009	0.012	0.23	0.32
D	0.604	0.610	15.34	15.49
E	0.292	0.298	7.42	7.57
e	0.032 BSC		0.80 BSC	
H	0.398	0.416	10.10	10.57
L	0.020	0.035	0.51	0.89
α	0°	8°	0°	8°

21-0032A

36-PIN PLASTIC SHRINK SMALL-OUTLINE PACKAGE

Maxim cannot assume responsibility for use of any circuitry other than circuitry entirely embodied in a Maxim product. No circuit patent licenses are implied. Maxim reserves the right to change the circuitry and specifications without notice at any time.

28 Maxim Integrated Products, 120 San Gabriel Drive, Sunnyvale, CA 94086 (408) 737-7600

© 1994 Maxim Integrated Products

Printed USA

MAXIM is a registered trademark of Maxim Integrated Products.