

# Multilayer Chip Antennas

## For GPS/2.4 GHz ISM Band

Conformity to RoHS Directive  
Halogen-free

ANT Series ANT016008LCD1575MA1

### SHAPES AND DIMENSIONS

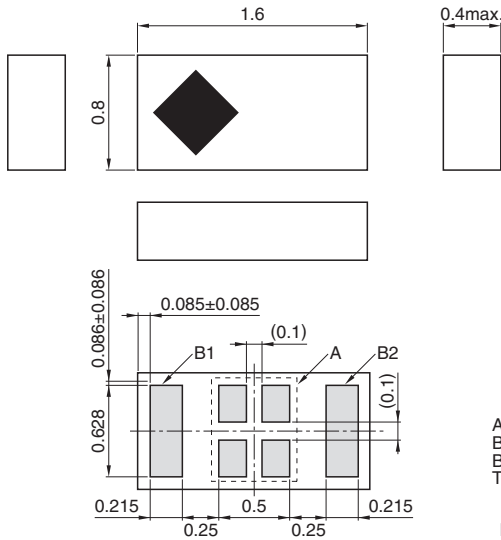

- Conformity to RoHS Directive: This means that, in conformity with EU Directive 2002/95/EC, lead, cadmium, mercury, hexavalent chromium, and specific bromine-based flame retardants, PBB and PBDE, have not been used, except for exempted applications.
- Halogen-free: Indicates that Cl content is less than 900ppm, Br content is less than 900ppm, and that the total Cl and Br content is less than 1500ppm.

• All specifications are subject to change without notice.

### RECOMMENDED PC BOARD PATTERNS

#### ELECTRODE

##### Front side

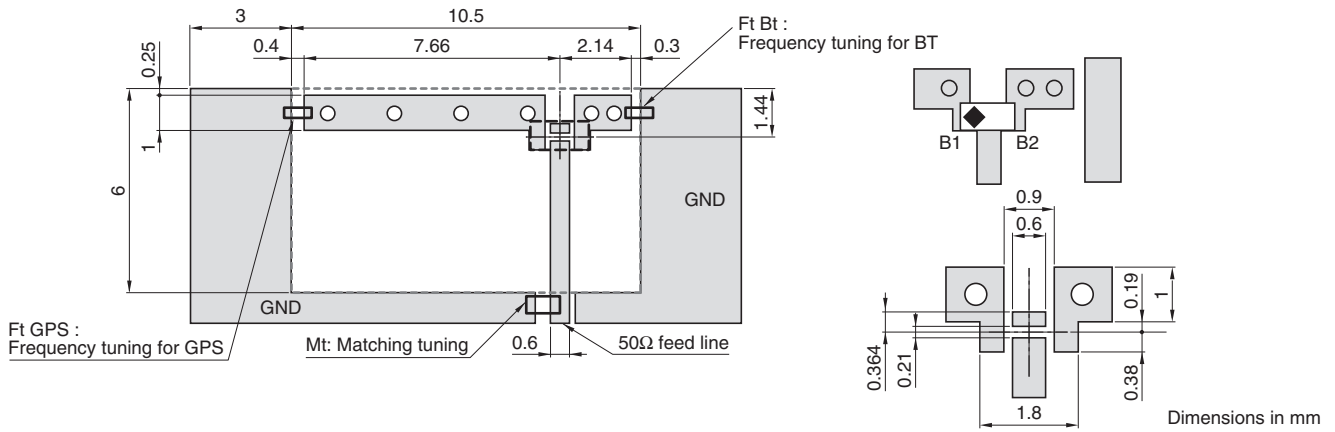

##### Back side

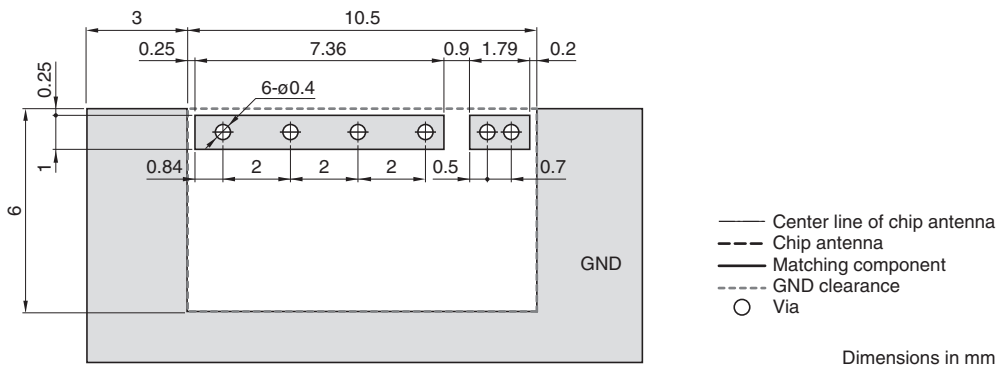

#### SOLDER RESIST

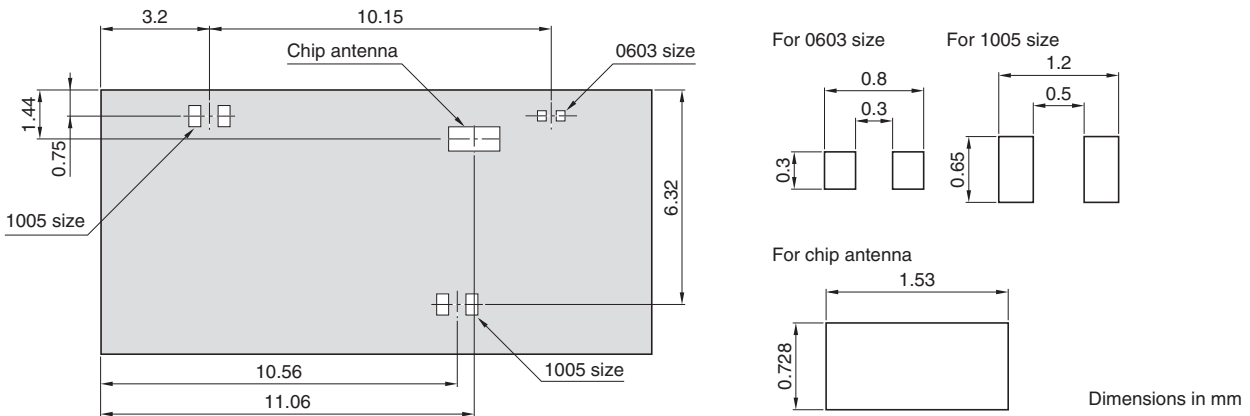

#### RECOMMEND APERTURE SIZE OF METAL MASK FOR SOLDER PRINTING

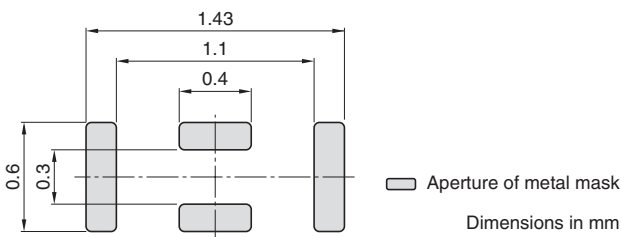

• All specifications are subject to change without notice.

## ELECTRICAL CHARACTERISTICS

Center frequency (F <sub>GPS</sub> , F <sub>BT</sub> )	F <sub>GPS</sub> 1575MHz, F <sub>BT</sub> 2442MHz	
Band width(BW) (F <sub>GPS</sub> , F <sub>BT</sub> )	F <sub>GPS</sub> ±1MHz, F <sub>BT</sub> ±42MHz	
VSWR (at BW)	4max.	
Polarization	Linear	
Impedance	50Ω	
PCB size	120×65×1.0mm	
Temperature range	Operating	-40 to +85°C
	Storage	-40 to +85°C

• This is typical antenna performance with the standard PCB.

## FREQUENCY CHARACTERISTICS

### EFFICIENCY AND VSWR

#### GPS Band

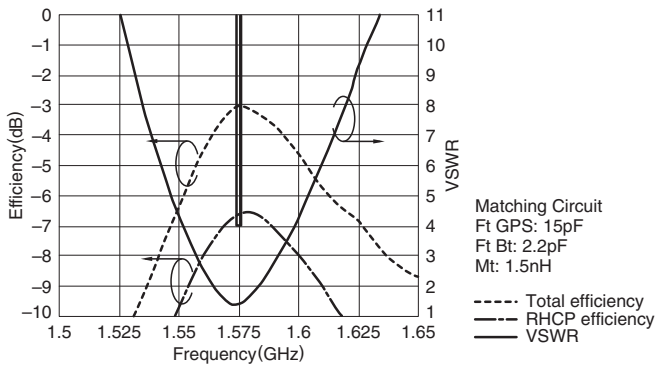

#### 2.4GHz ISM

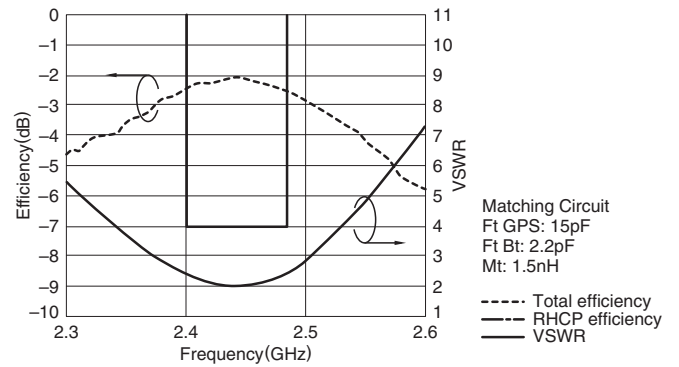

• All specifications are subject to change without notice.

**RADIATION PATTERNS**

Directivity angle

Vertical polarization



Horizontal polarization

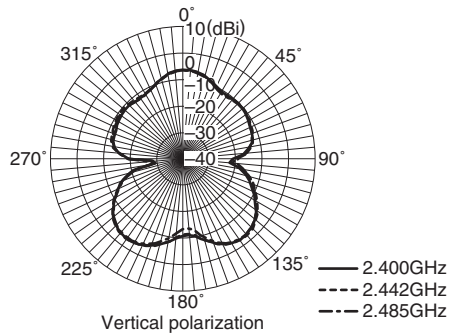
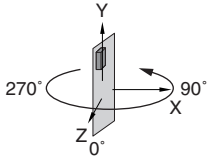
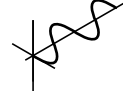

Frequency(GHz)	2.400	2.442	2.485
Average(dBi)	-8.22	-8.02	-8.47
Maximum(dBi)	-2.59	-2.31	-2.68
Minimum(dBi)	-29.47	-29.14	-29.11

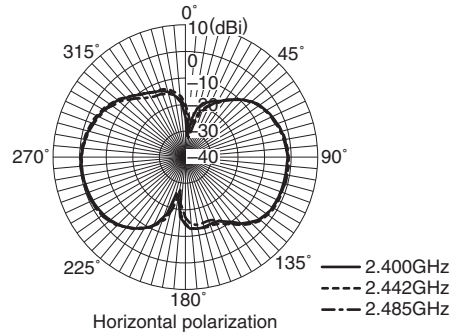

Frequency(GHz)	2.400	2.442	2.485
Average(dBi)	-4.93	-4.55	-4.89
Maximum(dBi)	-0.51	-0.17	-0.54
Minimum(dBi)	-32.16	-27.46	-32.81

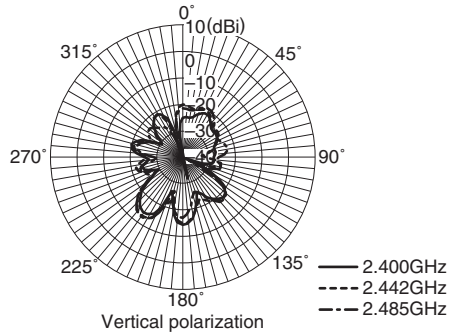
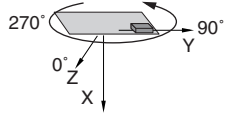

Frequency(GHz)	2.400	2.442	2.485
Average(dBi)	-21.39	-20.54	-20.87
Maximum(dBi)	-14.42	-12.97	-12.63
Minimum(dBi)	-48.20	-39.75	-37.58

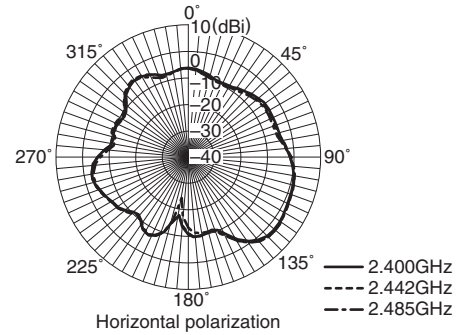

Frequency(GHz)	2.400	2.442	2.485
Average(dBi)	-4.18	-3.87	-4.13
Maximum(dBi)	2.41	2.97	2.95
Minimum(dBi)	-17.78	-17.90	-24.44

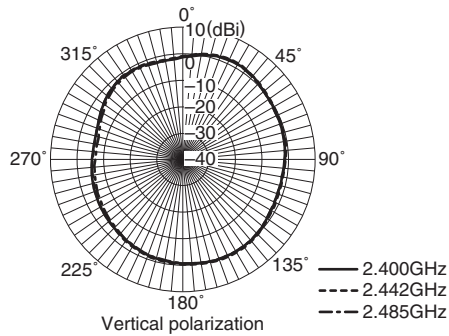
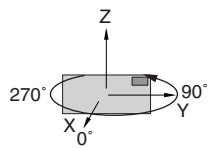

Frequency(GHz)	2.400	2.442	2.485
Average(dBi)	-1.40	-1.12	-1.54
Maximum(dBi)	1.44	1.79	1.55
Minimum(dBi)	-6.03	-6.19	-7.17

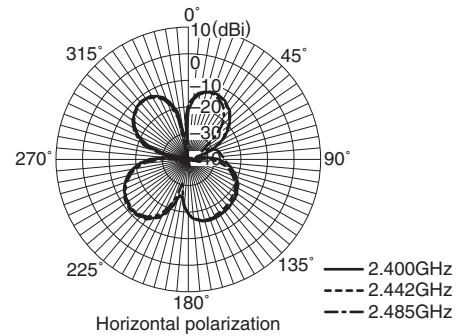

Frequency(GHz)	2.400	2.442	2.485
Average(dBi)	-16.24	-16.42	-16.73
Maximum(dBi)	-11.34	-11.01	-11.71
Minimum(dBi)	-44.47	-43.07	-42.83

• Tested antenna has been soldered. Evaluation board size is 120x65x1 mm.

• All specifications are subject to change without notice.

**RHCP**

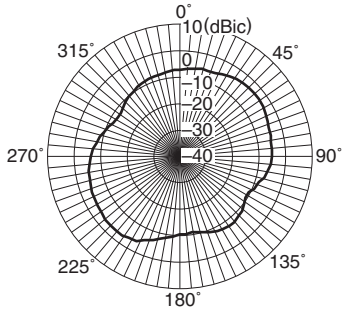

Frequency(GHz)	1.575
Average(dBic)	-6.3
Maximum(dBic)	-2.9
Minimum(dBic)	-12.2

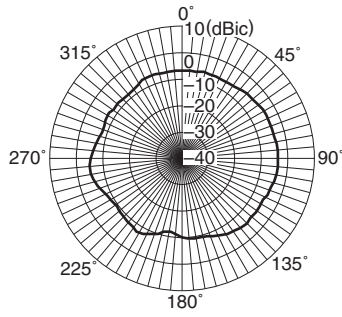

Frequency(GHz)	1.575
Average(dBic)	-6.5
Maximum(dBic)	-3.7
Minimum(dBic)	-12.1

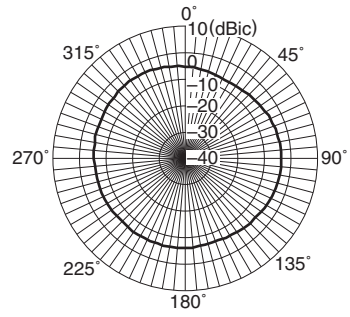

Frequency(GHz)	1.575
Average(dBic)	-5.3
Maximum(dBic)	-3.7
Minimum(dBic)	-6.7

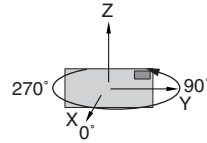
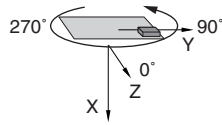
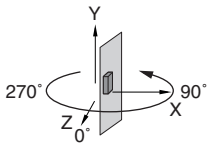

- Tested antenna has been soldered. Evaluation board size is 120x65x1 mm.