



# SmarterGlass

state-of-the-art display solutions

[www.smarterglass.com](http://www.smarterglass.com)  
978 997 4104  
[sales@smarterglass.com](mailto:sales@smarterglass.com)

**Product Specification**

**1. General Description**

The LD070WX3 is a Color Active Matrix Liquid Crystal Display with an integral Light Emitting Diode (LED) backlight system. The matrix employs a-Si Thin Film Transistor as the active element. It is a transmissive type display operating in the normally Black mode. This TFT-LCD has 7.0 inches diagonally measured active display area with WXGA resolution(800 horizontal by 1280 vertical pixel array). Each pixel is divided into Red, Green and Blue sub-pixels or dots which are arranged in vertical stripes. Gray scale or the brightness of the sub-pixel color is determined with a 8-bit gray scale signal for each dot, thus, presenting a palette of more than 16,772,216 colors.

The LD070WX3 has been designed to apply the interface method that enables low power, high speed, low EMI.

The LD070WX3 is intended to support applications where thin thickness, low power are critical factors and graphic displays are important. In combination with the vertical arrangement of the sub-pixels, the LD070WX3 characteristics provide an excellent flat display.

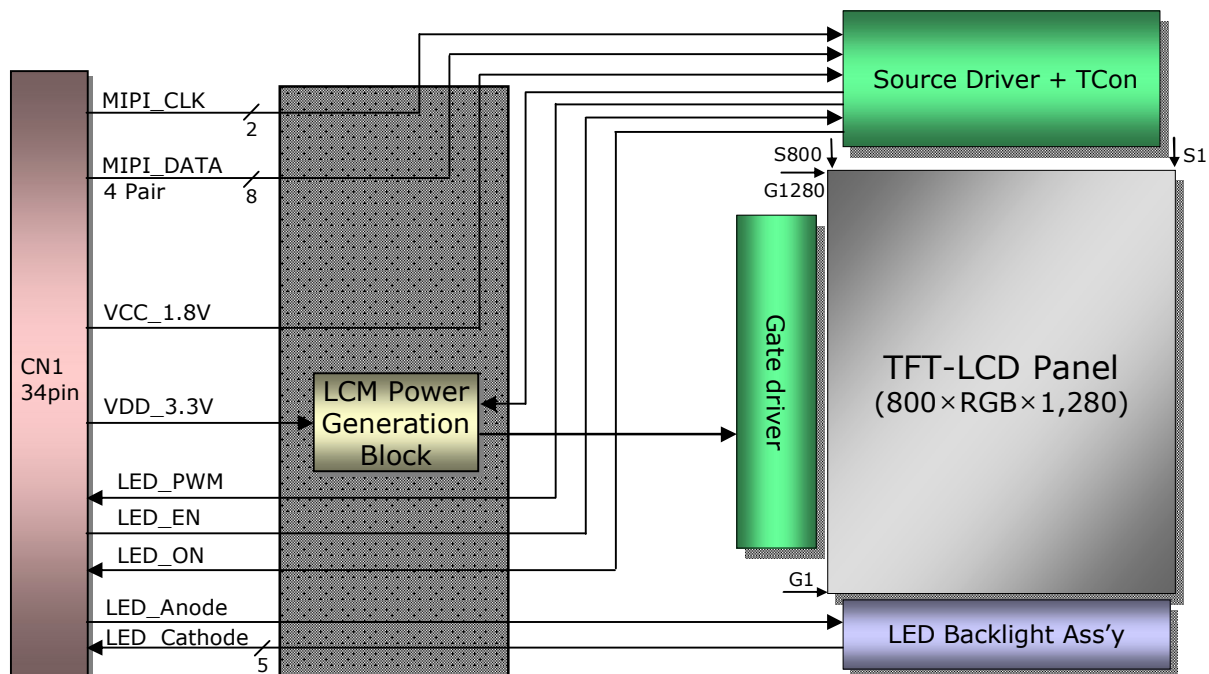

**General Features**

Active Screen Size	7.0 inches diagonal
Outline Dimension	104.32mm x 161.67mm x 2.12mm (Typ.)
Dot Pitch	0.03925mm × 0.11775mm
Pixel Format	800 horizontal By 1280 vertical Pixels RGB strip arrangement
Color Depth	16,7M colors (6-bit + 2-bit FRC)
Luminance, White	500 cd/m <sup>2</sup> (Typ.)
Weight	85g(Max.)
Display Operating Mode	Transmitting type, Normally black
Surface Treatment	Hard coat on the polarizer (ATW)

**Product Specification**

**2. Absolute Maximum Ratings**

The following are maximum values which, if exceeded, may cause faulty operation or damage to the unit.

**Table 1. ABSOLUTE MAXIMUM RATINGS**

Parameter	Symbol	Values		Units	Notes
		Min	Max		
Power Input Voltage	VCC	-0.5	5.0	V	at 25 ± 5°C
Operating Temperature	T <sub>OP</sub>	-10	60	°C	[Note 2-1,2,3,4]
Storage Temperature	H <sub>ST</sub>	-20	70	°C	[Note 2-1,2]

[Note 2-1] This rating applies to all parts of the module and should not be exceeded.

[Note 2-2] Maximum wet-bulb temperature is 39.2°C. Condensation of dew must be avoided as electrical current leaks will occur, causing a degradation of performance specifications.

[Note 2-3] The operating temperature only guarantees operation of the circuit and doesn't guarantee all the contents of Electro-optical specification.

[Note 2-4] Ambient temperature when the backlight is lit (reference value).

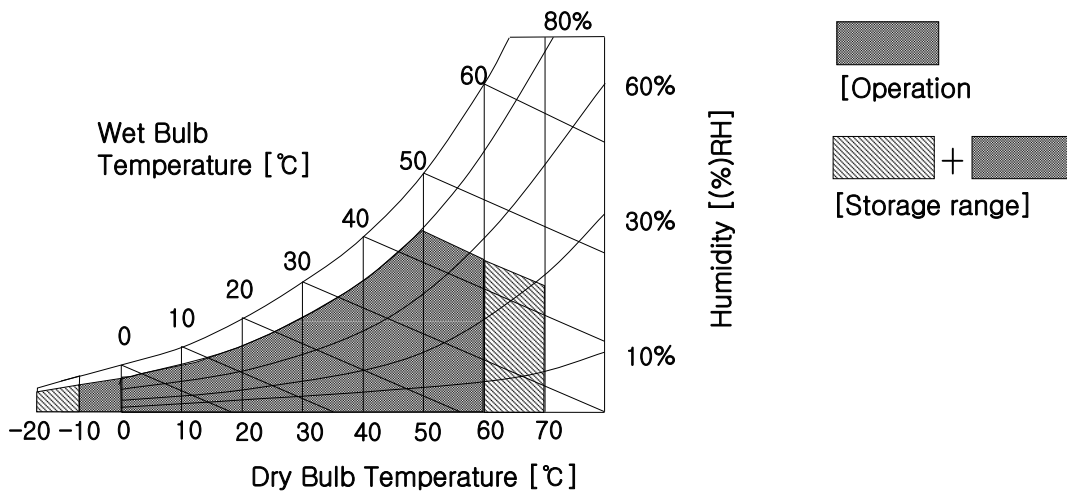

**Product Specification**

**3. Electrical Specifications**

**3-1. Electrical Characteristics**

The LD070WX3 requires two power inputs. One is employed to power the LCD electronics and to drive the TFT array and liquid crystal. The second input which powers the LED, is typically generated by an LED Driver. The LCD not include LED Driver.

**Table 2. ELECTRICAL CHARACTERISTICS**

Parameter	Symbol	Values			Unit	Notes
		Min	Typ	Max		
LCD :						
Power Supply Input Voltage	VDD	3.0	3.3	3.6	V	
Input High-Level Voltage	$V_{H\_DD}$	$0.7 \times VDD$	-	VDD	V	
Input Low-Level Voltage	$V_{IL\_DD}$	0	-	$0.3 \times VDD$	V	
Power Supply Input Current	$I_{DD}$	-	85	108	mA	[Note 1]
Logic Supply Input Voltage	VCC	1.75	1.8	1.9	V	
Input High-Level Voltage	$V_{H\_CC}$	$0.8 \times VCC$	-	VCC	V	
Input Low-Level Voltage	$V_{IL\_CC}$	0	-	$0.2 \times VCC$	V	
Power Supply Input Current	$I_{CC}$	-	15	19	mA	[Note 1]
Power Consumption	$P_{DD} + P_{CC}$	-	0.31	0.39	Watt	[Note 1]

[Note 1] The specified current and power consumption are under the VDD = 3.3V ,VCC = 1.8V, 25°C, fv = 60Hz condition whereas “Mosaic Pattern” is displayed and fv is the frame frequency.

**Table 3. Backlight Unit**

PARAMETER	SYMBOL	MIN.	TYP.	MAX.	UNIT	REMARK
LED forward Current	$I_f$	-	20	20.5	mA	Ta=25°C (per chain)
LED forward Voltage	$V_f$	-	15.0	16.5	V	Ta=25°C (@ Typ. Current, per chain)
Power Consumption	$P_{BL}$	-	1.500	1,650	mW	Ta=25°C (@ Typ. Current, per chain)

[Note 1] The permissible forward current of LED vary with environmental temperature.

[ LED Array Structure ]

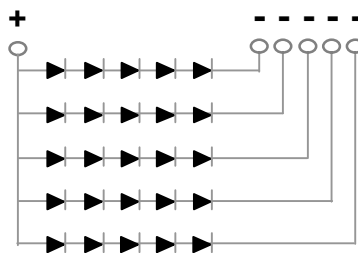

**Product Specification**

**3-2. Interface (Input Terminal)**

This LCD employs one interface connections, a 34 pin connector is used for the module electronics interface.  
(Connector Type : AXT634124, Matching Connector : AXT534124)

**Table 4. Module Connection Pin Configuration(cn1)**

No.	Symbol	Description	No.	Symbol	Description
1	GND	Ground	2	VDD (3.3V)	Power supply for analog
3	D0N	MIPI data negative signal	4	VDD (3.3V)	Power supply for analog
5	D0P	MIPI data positive signal	6	VDD (3.3V)	Power supply for analog
7	GND	Ground	8	GND	Ground
9	D1N	MIPI data negative signal	10	VCC (1.8V)	Power supply for digital
11	D1P	MIPI data positive signal	12	VCC (1.8V)	Power supply for digital
13	GND	Ground	14	GND	Ground
15	CLKN	MIPI CLK negative signal	16	LED_EN (1.8V)	Input, SDIC LED Logic on/off
17	CLKP	MIPI CLK positive signal	18	LED_PWM (3.3V)	Output, LED Dimming control PWM
19	GND	Ground	20	LED_ON (3.3V)	Output, External LED Driver On/Off Signal
21	D2N	MIPI data negative signal	22	ANODE	Power supply for LED[Anode]
23	D2P	MIPI data positive signal	24	ANODE	Power supply for LED[Anode]
25	GND	Ground	26	CATHODE1	Power supply for LED[Cathode]
27	D3N	MIPI data negative signal	28	CATHODE2	Power supply for LED[Cathode]
29	D3P	MIPI data positive signal	30	CATHODE3	Power supply for LED[Cathode]
31	GND	Ground	32	CATHODE4	Power supply for LED[Cathode]
33	BIST (1.8V)	Input, BIST Mode ('L' Active)	34	CATHODE5	Power supply for LED[Cathode]

**Product Specification**

**3-3. CABC Function description**

The LD070WX3 offers Content Adaptive Brightness Control (CABC) function. The function is used to generate a proper PWM signal based on internal CABC algorithms. User could apply this PWM signal to control other devices (Such as LED driver IC). When the CABC function is enabled and cooperate with external circuits, the power consumption of backlight will be reduced with keeping acceptable display quality.

**Table 4. CABC Function description**

Symbol		Description	Remark
LED_EN	-	SDIC CABC Logic on/off control signal	
LED_ON	-	External LED Driver on/off control signal	
MIPI command	CABC_EN [1:0]	00 Moving Image Mode : The duty of LED PWM pin is controlled by CABC algorithm.	* Power consumption reduction ratio is about 30%.
		01 Still Picture Mode: The duty of LED PWM pin is controlled by CABC algorithm.	* Power consumption reduction ratio is about 10% to 20%.
		10 User Interface Mode: The duty of LED PWM pin is controlled by CABC algorithm.	* Power consumption reduction ratio is about up to 10%.
		11 CABC Off mode: The duty of LED PWM pin is 100%	

\* The Power consumption reduction ratio can be changed by system's CABC configuration .

**Product Specification**

**4. MIPI Interface**

**4-1. General Description**

The LD070WX3 supports the Mobile Industry Process Interface (MIPI) is a differential small amplitude serial interface for high-speed data transfer through the following lines: DATA\_P/N 4Pair, CLK\_P/N 1Pair  
The specifications of MIPI supported by the D-IC meet the MIPI specifications Version 1.01(DSI) with Version 0.90 D-PHY.

**4-2. MIPI DSI Protocol**

MIPI DSI Protocol ( MIPI DSI version 1.01.00 with D-PHY version 0.90.00) is in accordance with the MIPI specification as published by MIPI ALLIANCE; refer to these specifications for more information on the MIPI Protocol.

The LD070WX3 supports only Video Mode operation because it does not have frame buffer memory. However it has bidirectional DSI interface so that DSI host can read display status registers.

**4-2-1. General Packet Structure**

Two packet structure are defined for low-level protocol communication : Long packets and Short packets. For both packets structures, the Data Identifier is always the first byte of the packet.

**Short Packet Format**

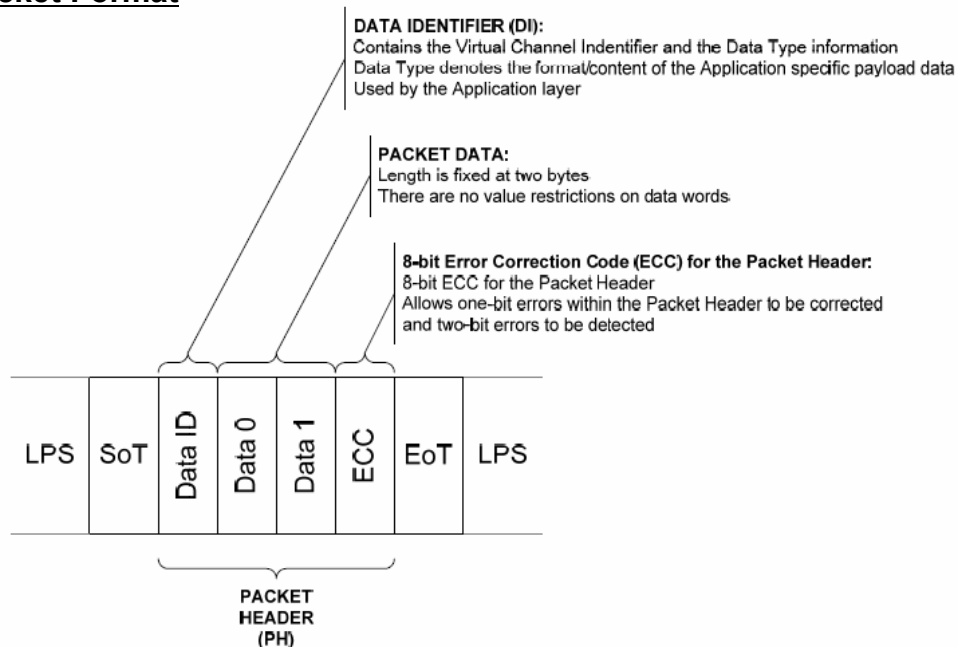

A Short packet shall contain an 8-bit Data ID followed by two command or data bytes and an 8-bit ECC; a Packet Footer shall not be present. Short packet shall be four bytes in length.

**Product Specification**

**Long Packet Format**

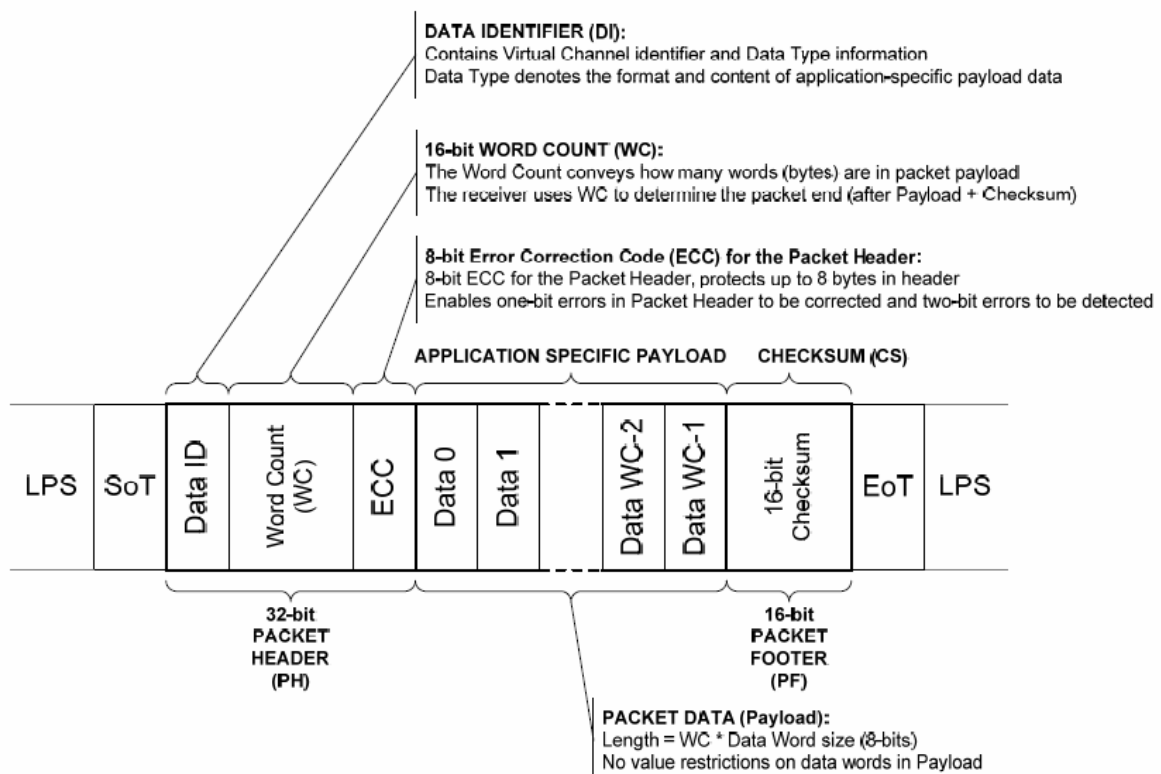

A long packet shall consist of three elements : a 32-bit Packet Header (PH), an application-specific Data Payload with a variable number of bytes, and a 16-bit Packet Footer (PF).

The Packet Header is further composed of three elements: an 8-bit Data Identifier, a 16-bit Word Count, and 8-bit ECC. The Packet Footer has one element, a 16-bit checksum.

Long packets can be from 6 to 65,541 bytes in length.



**Product Specification**

**4-2-2. Data Identifier Byte**

The first byte of any packet is the DI (Data Identifier) byte.

[7:6] : These two bits identify the data as directed to one of four virtual channels.

[5:0] : These six bits specify the Data Type.

The followings are the description of Data Types.

Data Type, hex	Data Type, binary	Description	Packet Size
01h	00 0001	Sync Event, V Sync Start	Short
11h	01 0001	Sync Event, V Sync End	Short
21h	10 0001	Sync Event, H Sync Start	Short
31h	11 0001	Sync Event, H Sync End	Short
08h	00 1000	End of Transmission packet (EoTp)	Short
02h	00 0010	Color Mode (CM) Off Command	Short
12h	01 0010	Color Mode (CM) On Command	Short
22h	10 0010	Shut Down Peripheral Command	Short
32h	11 0010	Turn On Peripheral Command	Short
03h	00 0011	Generic Short WRITE, no parameters	Short
13h	01 0011	Generic Short WRITE, 1 parameter	Short
23h	10 0011	Generic Short WRITE, 2 parameters	Short
04h	00 0100	Generic READ, no parameters	Short
14h	01 0100	Generic READ, 1 parameter	Short
24h	10 0100	Generic READ, 2 parameters	Short
05h	00 0101	DCS Short WRITE, no parameters	Short
15h	01 0101	DCS Short WRITE, 1 parameter	Short
06h	00 0110	DCS READ, no parameters	Short
37h	11 0111	Set Maximum Return Packet Size	Short
09h	00 1001	Null Packet, no data	Long
19h	01 1001	Blanking Packet, no data	Long
29h	10 1001	Generic Long Write	Long
39h	11 1001	DCS Long Write/write_LUT Command Packet	Long
0Eh	00 1110	Packed Pixel Stream, 16-bit RGB, 5-6-5 Format	Long
1Eh	01 1110	Packed Pixel Stream, 18-bit RGB, 6-6-6 Format	Long
2Eh	10 1110	Loosely Packed Pixel Stream, 18-bit RGB, 6-6-6 Format	Long
3Eh	11 1110	Packed Pixel Stream, 24-bit RGB, 8-8-8 Format	Long
x0h and xFh, unspecified	xx 0000 xx 1111	DO NOT USE All unspecified codes are reserved	

**Product Specification**

**4-2-3. Pixel Stream and Interface Timing**

**Packed Pixel Stream structure for 24 bit pixel format (8-8-8) data packet.**

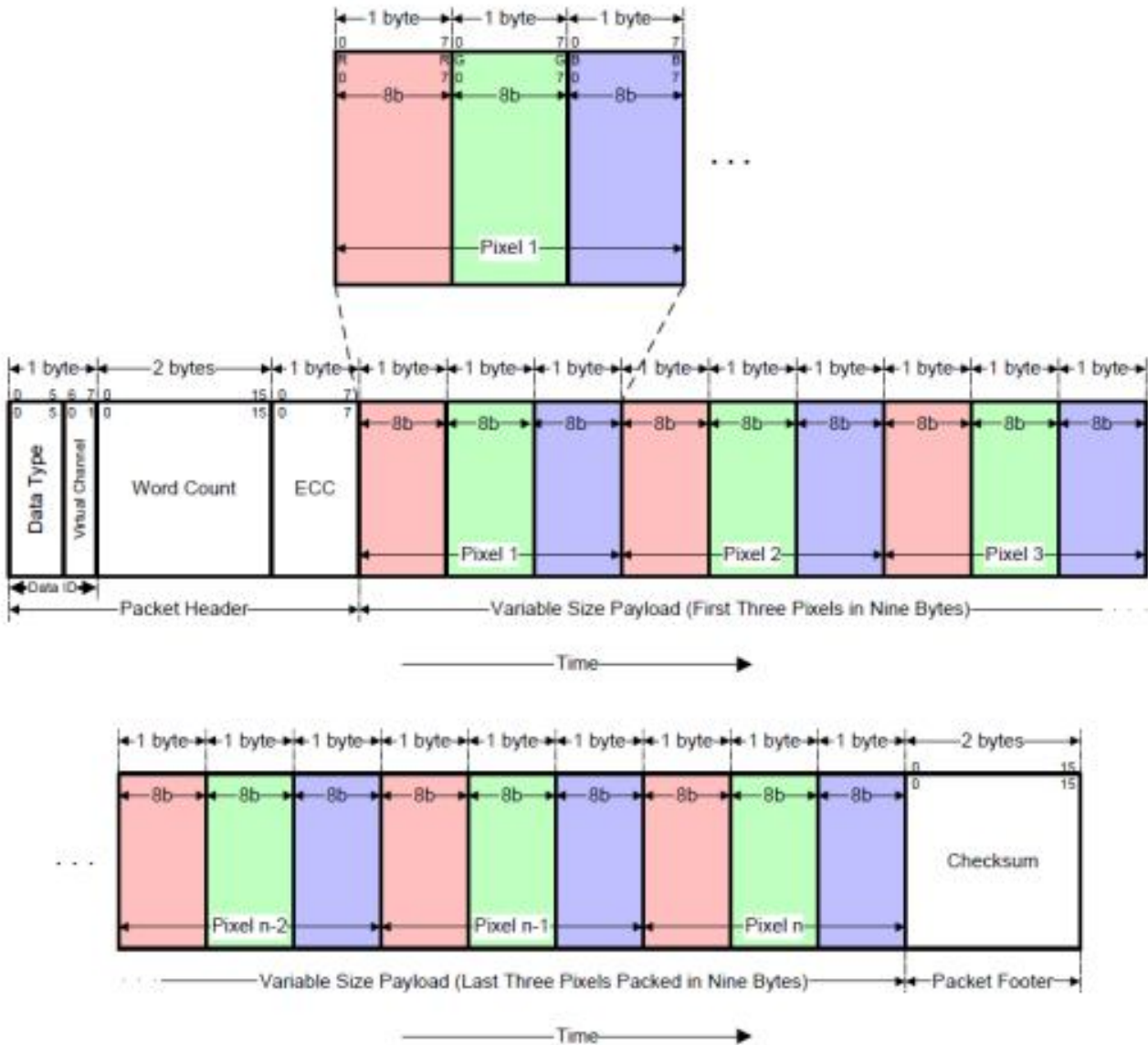

**Product Specification**

**4-2-4. Signal Timing Specifications**

This is the signal timing required at the input of the User connector. All of the interface signal timing should be satisfied with the following specifications and specifications of MIPI Tx/Rx for its proper operation.

ITEM	Symbol	Min	Typ	Max	Unit	Note
FCLK	Frame Frequency	$f_{FRAME}$	55	60	65	Hz
Hsync	Period	$t_{HP}$	860	864	-	tCLK
	Display data	$t_{HD}$	800			
	Width	$t_{HPW}$	1	8	40	
	Horizontal back porch	$t_{HBP}$	48			
	Horizontal front porch	$t_{HFP}$	12	16	-	
Vsync	Period	$t_{VP}$	1286	1288	-	tHP
	Display data	$t_{VD}$	1280			
	Width	$t_{VPW}$	1	1	2	
	Vertical back porch	$t_{VBP}$	3			
	Vertical front porch	$t_{VFP}$	3	5	-	

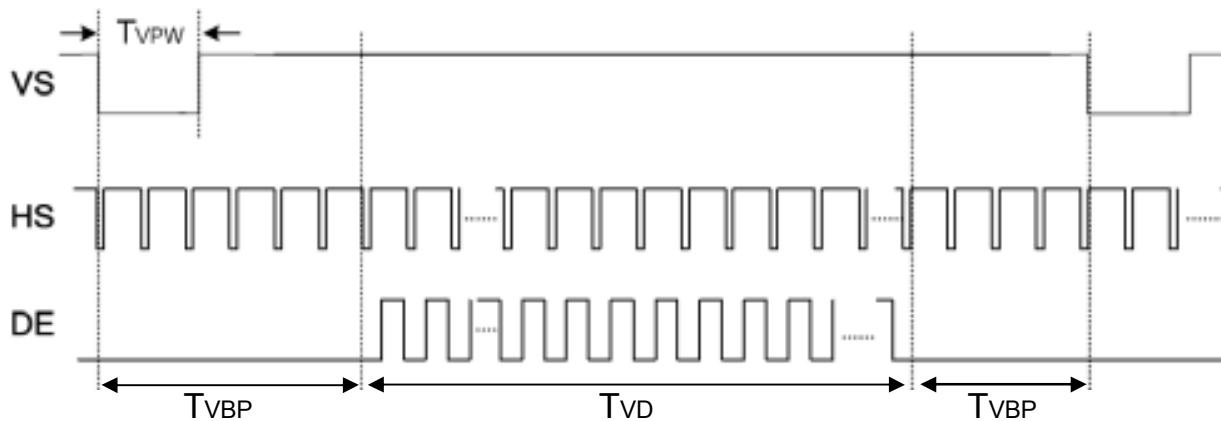

**Product Specification**

**4-3. MIPI Signal Timing Specification**

**4-3-1. MIPI DC Specification**

VDD= 3.0 to 3.6V, AVDD= 8.0 to 13.5V, GND=AGND= 0V, Ta = -20 to +60°C@SDIC

Parameter	Symbol	Min.	Typ.	Max.	Unit	Remark
MIPI Characteristics for High Speed Receiver						
Single-ended input low voltage	VILHS	-40	-	-	mV	
Single-ended input high voltage	VIHHS	-	-	460	mV	
Common-mode voltage	VCMRXDC	155	200	330	mV	
Differential input impedance	ZID	-	100	-	ohm	
HS transmit differential voltage (VOD=VDP-VDN)	VOD	120	200	250	mV	
MIPI Characteristics for Low Power Mode						
Pad signal voltage range	VI	-50	-	1350	mV	
Ground shift	VGNDSH	-50	-	50	mV	
Logic 0 input threshold	VIL	0	-	500	mV	
Logic 1 input threshold	VIH	1000	-	1350	mV	
Input hysteresis	VHYST	25	-	-	mV	
Output low level	VOL	-150	-	150	mV	
Output high level	VOH	1.1	1.2	1.3	V	
Logic 0 contention threshold	VILCD_Max	-	-	200	mV	
Logic1 contention threshold	VIHCD_Min	450	-	-	mV	

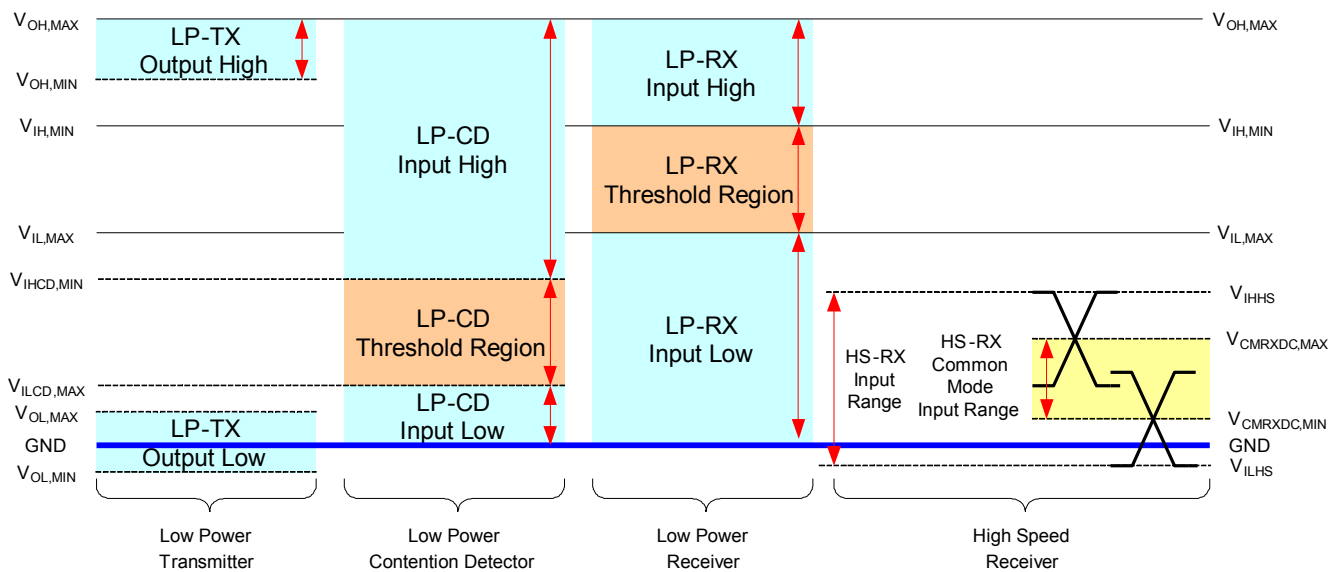

**MIPI DC Diagram**

Product Specification

4-3-2. MIPI signal AC Specification

◆ LP Transmitter AC Specification

Parameter	Symbol	Min.	Typ.	Max.	Unit	Remark
15%-85% rise time and fall time	$T_{RLP} / T_{FLP}$	-	-	35	ns	
30%-85% rise time and fall time	$T_{REOT}$	-	-	35	ns	
Pulse width of the LP exclusive-OR Clock	First LP exclusive-OR clock pulse after STOP state or last pulse before stop state	50	-	-	ns	
	All other pulses	50	-	-	ns	
Period of the LP exclusive-OR clock	$T_{LP-PER-TX}$	100	-	-	ns	
Slew Rate@ CLOAD = 0pF	$\delta V / \delta t_{SR}$	20	-	500	mV/ns	
Slew Rate@ CLOAD = 5pF		20	-	200	mV/ns	
Slew Rate@ CLOAD = 20pF		20	-	150	mV/ns	
Slew Rate@ CLOAD = 70pF		20	-	100	mV/ns	
Load Capacitance	$C_{LOAD}$	-	-	70	pF	

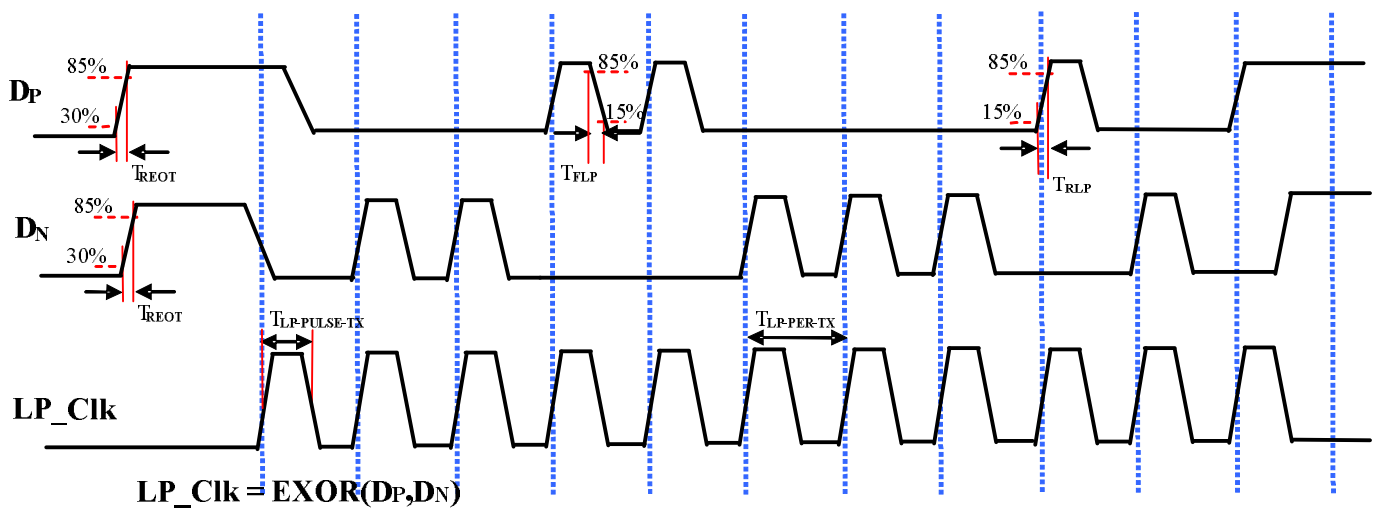

LP Transmitter Timing Definitions

**Product Specification**

**4-3-3. MIPI signal AC Specification**

**◆ High Speed Transmission specification**

Parameter	Symbol	Min.	Typ.	Max.	Unit	Remark
UI instantaneous	$UI_{INST}$	2	-	5.56	ns	
Data to Clock Skew [measured at transmitter]	$T_{SKEW[TX]}$	-0.1	-	0.1	ns	
Data to Clock Setup Time [measured at receiver]	$T_{SETUP[RX]}$	0.7	-	-	ns	
Data to Clock Hold Time [measured at receiver]	$T_{HOLD[RX]}$	0.7	-	-	ns	
20% - 80% rise time and fall time	$t_R / t_F$	150	-	-	ps	
		-	-	0.3	$UI_{INST}$	

1. This value corresponds to a minimum 180 Mbps data rate.
2. The minimum UI shall not be violated for any single bit period, i.e., any DDR half cycle within a data burst.
3. Total silicon and package delay budget of 0.2ns
4. Total setup and hold window for receiver of 1.4ns.

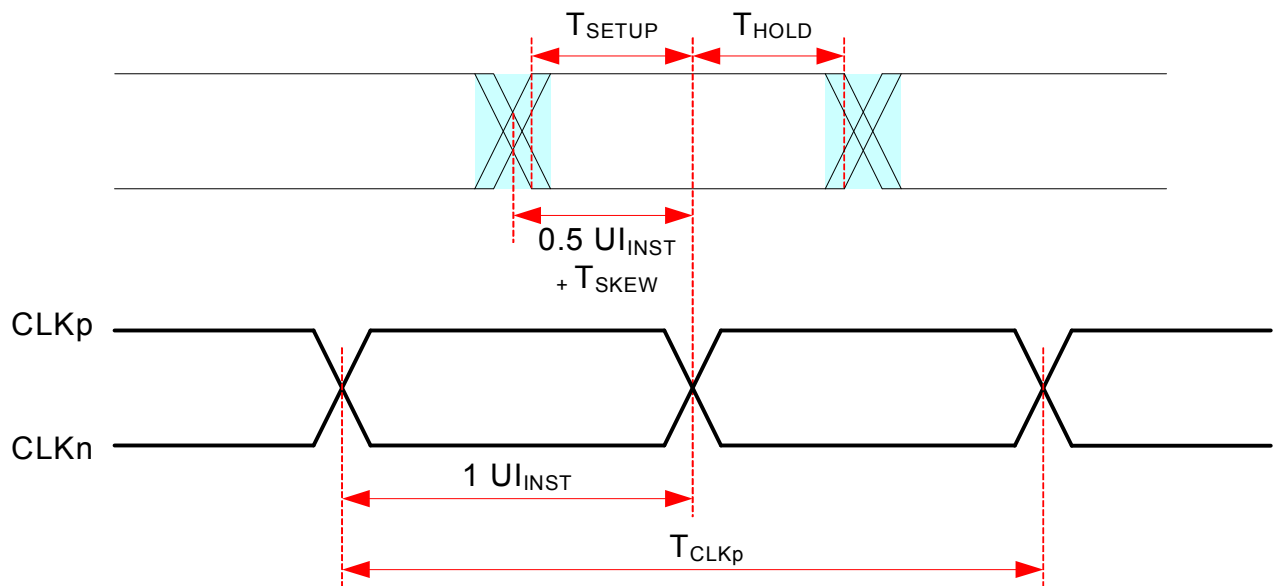

**Data to Clock Timing Definitions**

**Product Specification**

**4-4. MIPI Command Registers**

Following table list all the MIPI control registers and bit name definition for LD070WX3. Refer to the next section for detail register function description.

Setting of all the MIPI registers will take effect at the coming valid Vsync signal except GRB bit.

**(R01h) GRB : Software Reset**

Address	01h					Access Attribute			W
						Number of Parameter(s)			0
Parameter	D[7]	D[6]	D[5]	D[4]	D[3]	D[2]	D[1]	D[0]	Default Value
	No Argument								N/A
Description	When the Software Reset command is written, it causes a software reset. It resets the commands And parameters to their S/W Reset register values and all source are set to GND (display off).								
Restriction	(1) It will be necessary to wait 20msec before sending new command following software reset. (2) The display module loads all display supplier's factory default values to the registers during 5 msec.								

**(R11h) ENTER\_SLEEP\_MODE: Enter the Sleep-In Mode**

Address	10h					Access Attribute			W
						Number of Parameter(s)			0
Parameter	D[7]	D[6]	D[5]	D[4]	D[3]	D[2]	D[1]	D[0]	Default Value
	No Argument								Sleep-In Mode
Description	This command initiates the power-down sequence. The Sleep In profile will be executed when this command is received.								
Restriction	This commands has no effect when the display module is already in Sleep Mode.								

**(R10h) EXIT\_SLEEP\_MODE: Exit the Sleep-In Mode**

Address	11h					Access Attribute			W
						Number of Parameter(s)			0
Parameter	D[7]	D[6]	D[5]	D[4]	D[3]	D[2]	D[1]	D[0]	Default Value
	No Argument								Sleep-Out Mode
Description	This command initiates the power-down sequence. The Sleep Out profile will be executed when this command is received. The Sleep Out will load register value. It will be necessary to wait 5msec before sending next command.								
Restriction	This commands has no effect when the display module is already in Sleep Mode.								

**Product Specification**

**LCM MIPI Command**

	Register Setting		Remark
	Register	Data	
1	B2	7D	Tckv_oe timing adjustment for GPM function
2	AE	0B	Differential input impedance selection
3	B6	18	Gate OE width Control
4	EE	EA	Enter test mode 1
5	EF	5F	Enter test mode 2
6	F2	68	Increased MIPI CLK driving ability
7	EE	00	Exit test mode 1
8	EF	00	Exit test mode 2
9	D2	64	AVDDG OFF





Product Specification

4-6. Power Sequence

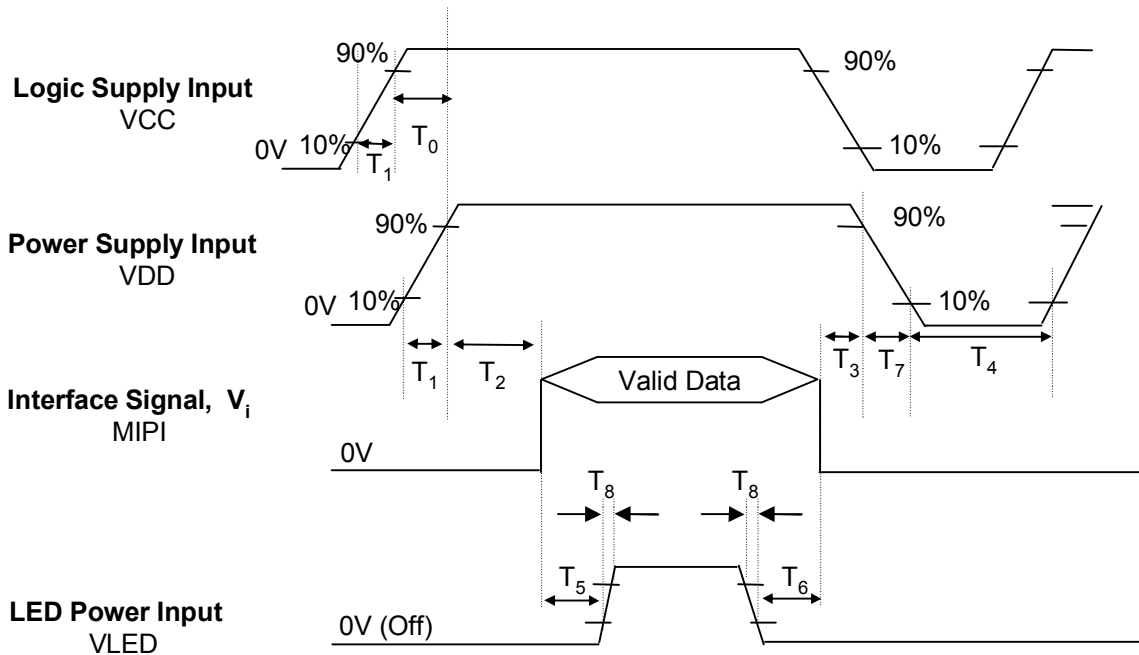

Table 7. POWER SEQUENCE TABLE

Logic Parameter	Value			Units
	Min.	Typ.	Max.	
T <sub>0</sub>	0	-	-	ms
T <sub>1</sub>	0.5	-	10	ms
T <sub>2</sub>	110	-	-	ms
T <sub>3</sub>	50	-	150	ms
T <sub>4</sub>	1,000	-	-	ms
T <sub>5</sub>	200	-	-	ms
T <sub>6</sub>	200	-	-	ms
T <sub>7</sub>	3	-	10	ms
T <sub>8</sub>	0.5	-	10	ms

Note)

1. Do not insert the mating cable when system turn on.
2. Valid Data have to meet "MIPI Signal Timing Specifications"
3. MIPI, VLED, VCC, VDD need to be on pull-down condition on invalid status.
4. LGD recommend the rising sequence of VLED after the VCC&VDD and valid status of MIPI turn on.

Product Specification

5. Optical Specifications

Optical characteristics are determined after the unit has been 'ON' and stable for approximately 5 minutes in a dark environment at 25°C. The values specified are at an approximate distance 50cm from the LCD surface at a viewing angle of  $\Phi$  and  $\Theta$  equal to 0°.

FIG. 1 presents additional information concerning the measurement equipment and method.

FIG. 1 Optical Characteristic Measurement Equipment and Method

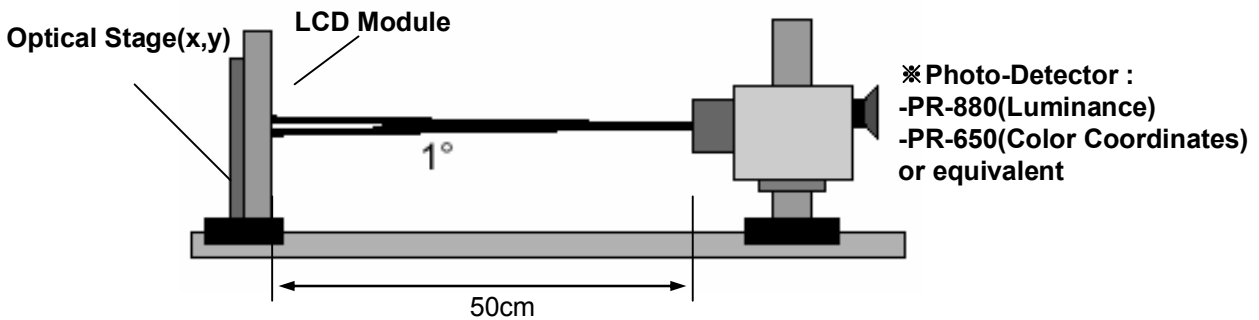

Table 8. OPTICAL CHARACTERISTICS

Ta=25°C, VCC=3.3V, VDD=1.8V, fv=60Hz, ILED = 20mA

Parameter	Symbol	Values			Units	Notes	
		Min	Typ	Max			
Contrast Ratio	CR	560	800	-		4-1	
Surface Luminance, white	L <sub>WH</sub>	350	500	-	nit	4-2	
Luminance Variation	$\delta_{\text{WHITE}}$	70	80	-	-	4-3	
Color gamut	NTSC	55	60	-	%	4-2	
Response Time	Tr <sub>R</sub> + Tr <sub>D</sub>	-	35	50	ms	4-4	
Color Coordinates	White	Wx	0.275	0.310	0.345	4-2	
		Wy	0.305	0.340	0.375		
Viewing Angle						4-5	
	x axis, right( $\Phi=0^\circ$ )	$\Theta_r$	-	85	-	degree	3 o'clock
	x axis, left ( $\Phi=180^\circ$ )	$\Theta_l$	-	85	-	degree	9 o'clock
	y axis, up ( $\Phi=90^\circ$ )	$\Theta_u$	-	85	-	degree	12 o'clock
	y axis, down ( $\Phi=270^\circ$ )	$\Theta_d$	-	85	-	degree	6 o'clock
Crosstalk (Vertical, Horizontal)	-	-	-	2.5	%	-	

## Product Specification

[Note 4-1] Contrast Ratio (CR) is defined mathematically as

$$\text{Contrast Ratio} = \frac{\text{Surface Luminance with all white pixels}}{\text{Surface Luminance with all black pixels}}$$

[Note 4-2] Surface luminance is measured at the center point( $L_1$ ) of the LCD with all pixels displaying white at the distance of 50cm by PR-880. Color Coordinates are measured at the center point( $L_1$ ) of the LCD with all pixels displaying red, green, blue and white at the distance of 50cm by PR-650. For more information, refer to the FIG 1 and FIG 2.

[Note 4-3] Luminance % uniformity is measured for 9 point For more information see FIG 2.

$$\delta_{\text{WHITE}} = \text{Minimum (L1,L2, ..... L9)} \div \text{Maximum (L1,L2, ..... L9)}$$

[Note 4-4] Response time is the time required for the display to transition from white to black (Rise Time,  $T_{rR}$ ) and from black to white (Decay Time,  $T_{rD}$ ). For additional information see FIG 3.

[Note 4-5] Viewing angle is the angle at which the contrast ratio is greater than 10. The angles are determined for the horizontal or x axis and the vertical or y axis with respect to the z axis which is normal to the LCD surface. For more information see FIG 4.

Product Specification

FIG. 2 Luminance

<measuring point for surface luminance & measuring point for luminance variation>

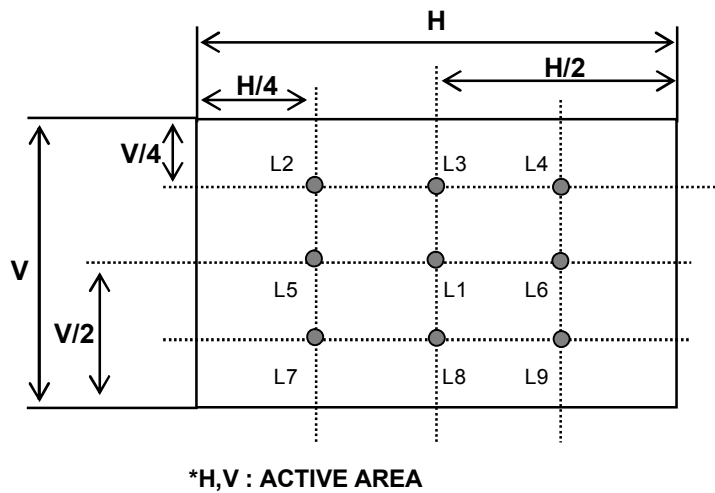
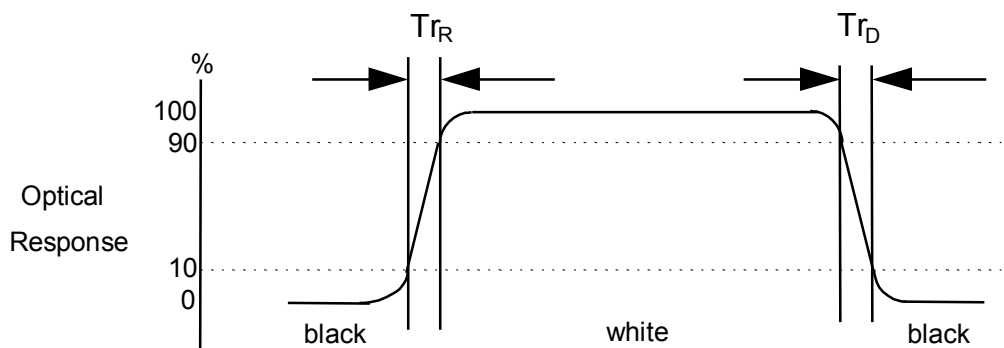

FIG. 3 Response Time

The response time is defined as the following figure and shall be measured by switching the input signal for “black” and “white”.



**Product Specification**

**FIG. 4 Viewing angle**

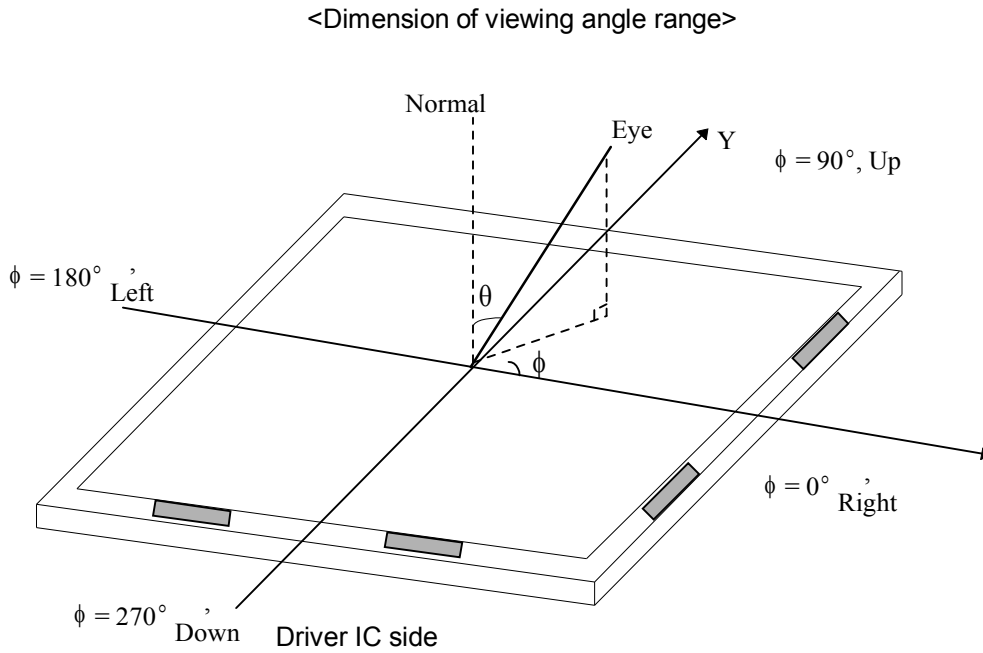

**FIG. 5. Crosstalk**

$$\left( \frac{|L_{A[or C]2} - L_{A[or C]1}|}{L_{A[or C]1}} \right) \times 100(\%) \text{ [Vertical]},$$

$$\left( \frac{|L_{B[or D]2} - L_{B[or D]1}|}{L_{B[or D]1}} \right) \times 100(\%) \text{ [Horizontal]}$$

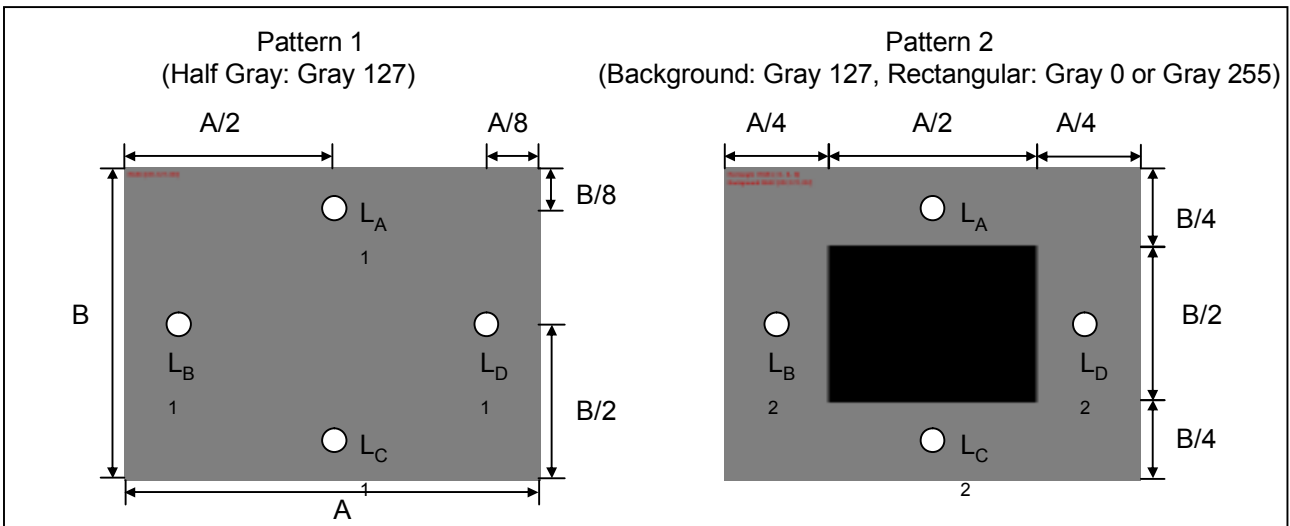

[그림9]

**Product Specification**

**6. Mechanical Characteristics**

The contents provide general mechanical characteristics for the model LD070WX3. In addition the figures in the next page are detailed mechanical drawing of the LCD.

Outline Dimension	Horizontal	104.32 mm (Typ.)
	Vertical	161.67 mm (Typ.)
	Thickness	2.12 mm (Typ.), 2.3mm(Max.)
Active Display Area	Horizontal	94.20 mm (Typ.)
	Vertical	150.72 mm (Typ.)
Weight	85g ( Max.)	
Surface Treatment	Hard coat on the polarizer (ATW)	

**Product Specification**

<FRONT VIEW>

Unit:[mm], General tolerance:  $\pm 0.2\text{mm}$

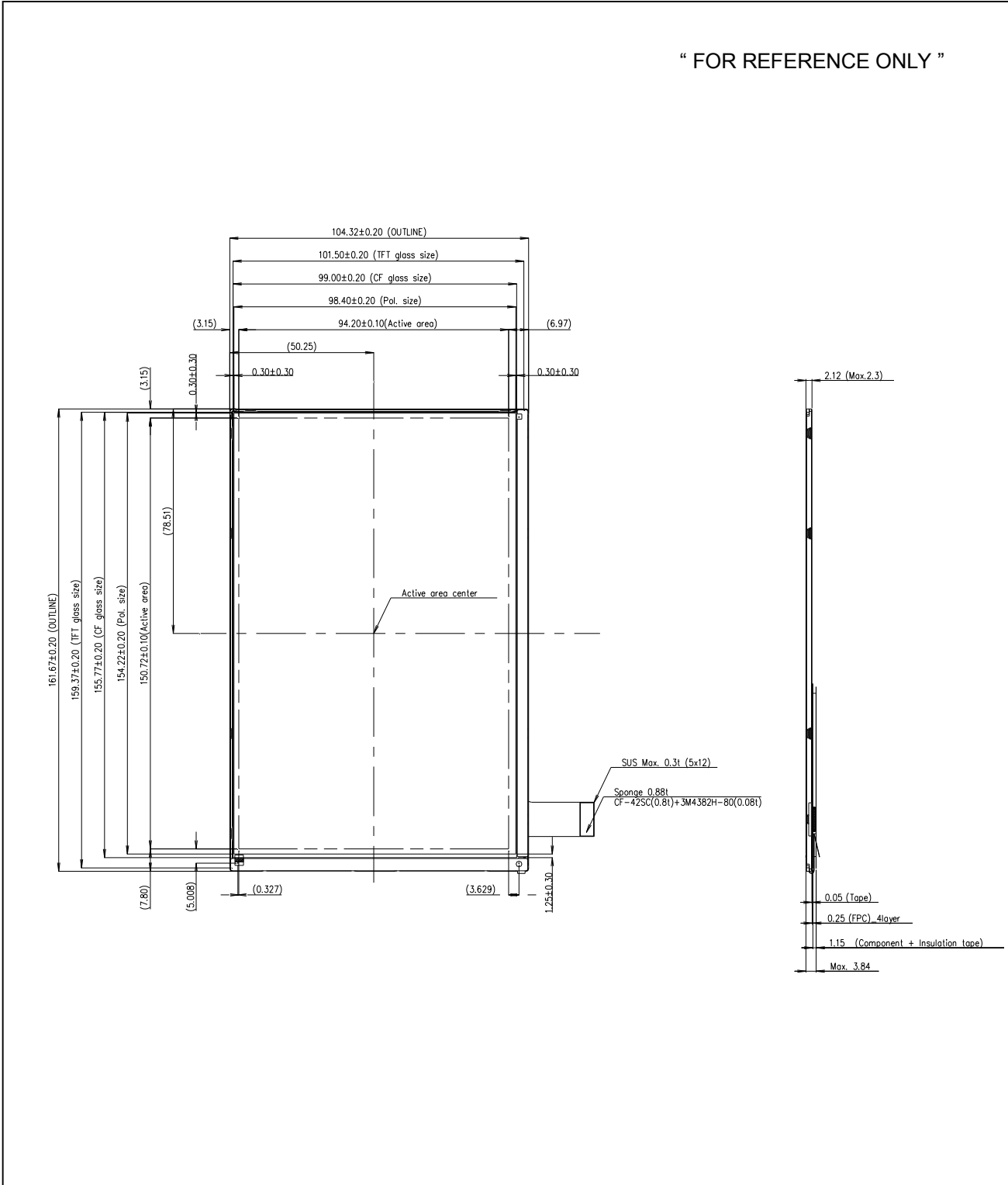



**Product Specification**

<REAR VIEW>

Unit:[mm], General tolerance:  $\pm 0.2\text{mm}$

“ FOR REFERENCE ONLY ”

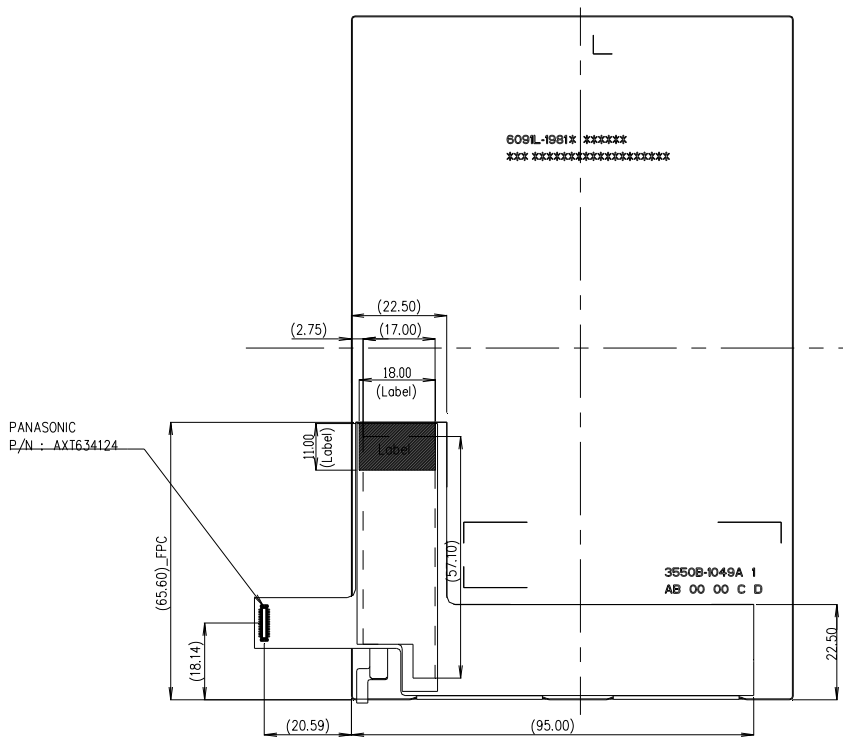

## Product Specification

### 8. International Standards

#### 8-1. Safety

- a) UL 60950-1, Second Edition, Underwriters Laboratories Inc.  
Information Technology Equipment - Safety - Part 1 : General Requirements.
- b) CAN/CSA C22.2 No.60950-1-07, Second Edition, Canadian Standards Association.  
Information Technology Equipment - Safety - Part 1 : General Requirements.
- c) EN 60950-1:2006 + A11:2009, European Committee for Electrotechnical Standardization (CENELEC).  
Information Technology Equipment - Safety - Part 1 : General Requirements.

#### 8-2. Environment

- a) RoHS, Directive 2002/95/EC of the European Parliament and of the council of 27 January 2003

**Product Specification**

**9. Packing**

**9-1. Designation of Lot Mark**

a) Lot Mark

A	B	C	D	E	F	G	H	I	J	K	L	M
---	---	---	---	---	---	---	---	---	---	---	---	---

A,B,C : SIZE(INCH)  
E : MONTH

D : YEAR  
F ~ M : SERIAL NO.

Note

1. YEAR

Year	2011	2012	2013	2014	2015	2016	2017	2018	2019	2020
Mark	A	B	C	D	E	F	G	H	J	K

2. MONTH

Month	Jan	Feb	Mar	Apr	May	Jun	Jul	Aug	Sep	Oct	Nov	Dec
Mark	1	2	3	4	5	6	7	8	9	A	B	C

b) Location of Lot Mark

Serial No. is printed on the label. The label is attached to FPC of the LCD module.  
This is subject to change without prior notice.

**9-2. Packing Form**

a) Package quantity in one box : 44 pcs

b) Box Size (mm) : 478mm × 365mm × 244mm

## Product Specification

### 10. Precautions

Please pay attention to the followings when you use this TFT LCD module.

#### 10-1. Mounting precautions

- (1) You should consider the mounting structure so that uneven force (ex. Twisted stress) is not applied to the module. And the case on which a module is mounted should have sufficient strength so that external force is not transmitted directly to the module.
- (2) Please attach the surface transparent protective plate to the surface in order to protect the polarizer. Transparent protective plate should have sufficient strength in order to resist external force.
- (3) You should adopt radiation structure to satisfy the temperature specification.
- (4) Acetic acid type and chlorine type materials for the cover case are not desirable because the former generates corrosive gas of attacking the polarizer at high temperature and the latter causes circuit break by electro-chemical reaction.
- (5) Do not touch, push or rub the exposed polarizers with glass, tweezers or anything harder than HB pencil lead. And please do not rub with dust clothes with chemical treatment. Do not touch the surface of polarizer for bare hand or greasy cloth. (Some cosmetics are detrimental to the polarizer.)
- (6) When the surface becomes dusty, please wipe gently with absorbent cotton or other soft materials like chamois soaks with petroleum benzene. Normal-hexane is recommended for cleaning the adhesives used to attach front / rear polarizers. Do not use acetone, toluene and alcohol because they cause chemical damage to the polarizer.
- (7) Wipe off saliva or water drops as soon as possible. Their long time contact with polarizer causes deformations and color fading.
- (8) Do not open the case because inside circuits do not have sufficient strength.

#### 10-2. Operating precautions

- (1) The spike noise causes the mis-operation of circuits. It should be lower than following voltage :  
 $V = \pm 200\text{mV}$  (Over and under shoot voltage)
- (2) Response time depends on the temperature. (In lower temperature, it becomes longer.)
- (3) Brightness depends on the temperature. (In lower temperature, it becomes lower.)  
And in lower temperature, response time (required time that brightness is stable after turned on) become longer.
- (4) Be careful for condensation at sudden temperature change. Condensation makes damage to polarizer or electrical contacted parts. And after fading condensation, smear or spot will occur.
- (5) When fixed patterns are displayed for a long time, remnant image is likely to occur.
- (6) Module has high frequency circuits. Sufficient suppression to the electromagnetic interference shall be done by system manufacturers. Grounding and shielding methods may be important to minimize the interference.
- (7) This module is not designed to attach TSP (touch screen panels). If TSP is applied, LPL can't guarantee the 'Ripple' related problems.

## Product Specification

### 10-3. Electrostatic discharge control

Since a module is composed of electronic circuits, it is not strong to electrostatic discharge. Make certain that treatment persons are connected to ground through wrist band etc. And don't touch interface pin directly.

### 10-4. Precautions for strong light exposure

Strong light exposure causes degradation of polarizer and color filter.

### 10-5. Storage

When storing modules as spares for a long time, the following precautions are necessary.

- (1) Store them in a dark place. Do not expose the module to sunlight or fluorescent light. Keep the temperature between 5°C and 35°C at normal humidity.
- (2) The polarizer surface should not come in contact with any other object.  
It is recommended that they be stored in the container in which they were shipped.

### 10-6. Handling precautions for protection film

- (1) When the protection film is peeled off, static electricity is generated between the film and polarizer.  
This should be peeled off slowly and carefully by people who are electrically grounded and with well ion-blown equipment or in such a condition, etc.
- (2) The protection film is attached to the polarizer with a small amount of glue. If some stress is applied to rub the protection film against the polarizer during the time you peel off the film, the glue is apt to remain on the polarizer.  
Please carefully peel off the protection film without rubbing it against the polarizer.
- (3) When the module with protection film attached is stored for a long time, sometimes there remains a very small amount of glue still on the polarizer after the protection film is peeled off.
- (4) You can remove the glue easily. When the glue remains on the polarizer surface or its vestige is recognized, please wipe them off with absorbent cotton waste or other soft material like chamois soaked with normal-hexane.