

IC for CMOS System Reset

Monolithic IC PST81XX, 82XX Series

Outline

This IC functions in a variety of CPU systems and other logic systems, to detect supply voltage and reset the system accurately when the power is turned on or interrupted.

To $\pm 1.5\%$ of detection voltage accuracy of the conventional models, a maximum of $\pm 0.5\%$ of super-high precision is realized, and it is more suitable for battery detection etc. Moreover, the mounting area significantly contributes to space saving using the SSON package.

Features

- | | |
|----------------------------------|--|
| 1. Ultra-high accuracy | $V_{TH} \pm 0.5\%/2.0\sim 6.0V$
$V_{TH} \pm 0.8\%/0.8\sim 1.9V$ |
| 2. Ultra-low current consumption | 0.25 μ A typ. |
| 3. Ultra-small package | 1.10 \times 1.40mm (SSON-4A) |
| 4. Operating temperature range | -40 \sim +105 $^{\circ}$ C |
| 5. Detecting voltage rank | 0.8 \sim 6.0V (0.1V step) |
| 6. Output configuration | PST81XX series CMOS output
PST82XX series Open drain output |

Packages

- SOT-25A
- SC-82ABA
- SC-82ABB
- SSON-4A

Applications

1. Reset circuits for microcomputers, CPUs and MPUs
2. Reset circuits for logic circuits
3. Battery voltage check circuits
4. Back-up power supply switching circuits
5. Level detection circuits

Block Diagram

■ **PST81XXNX, PST81XXRX, PST81XXUX**
 (SOT-25A) (SSON-4A) (SC-82ABA/-82ABB)

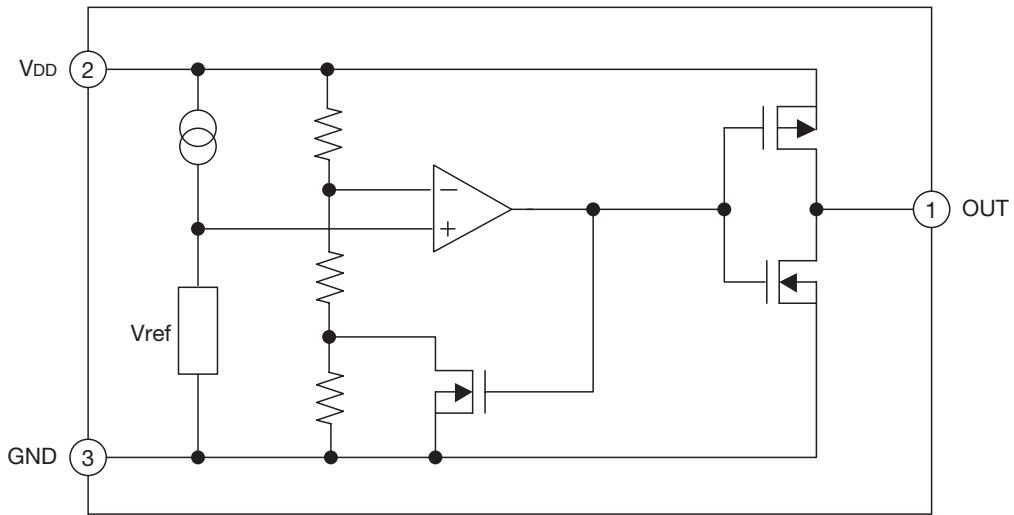

■ **PST82XXNX, PST82XXRX, PST82XXUX**
 (SOT-25A) (SSON-4A) (SC-82ABA/-82ABB)

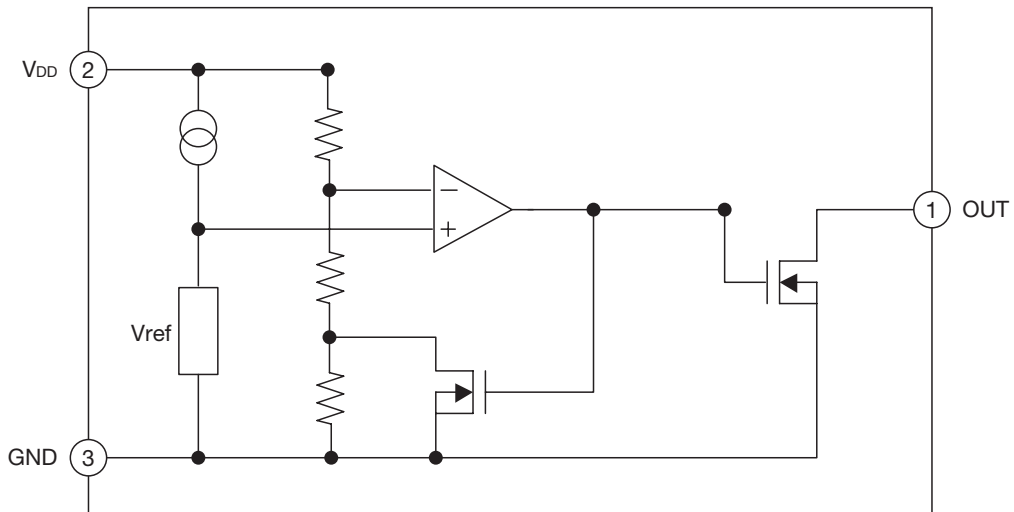

Pin Assignment

PST81XX, PST82XX

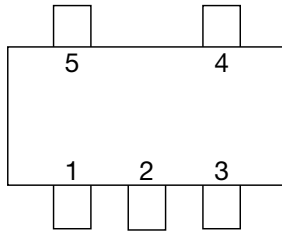

SOT-25A
(TOP VIEW)

1	OUT
2	V _{DD}
3	GND
4	N.C
5	N.C

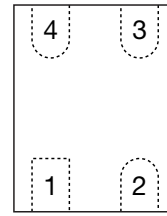

SSON-4A
(TOP VIEW)

1	OUT
2	GND
3	N.C
4	V _{DD}

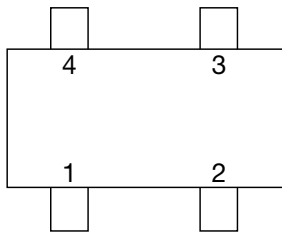

SC-82ABA
SC-82ABB
(TOP VIEW)

1	OUT
2	V _{DD}
3	N.C
4	GND

Pin Description

PST81XXNX, PST82XXNX (SOT-25A)

Pin No.	Pin name	Functions
1	OUT	Reset Signal Output Pin
2	V _{DD}	V _{DD} Pin / Voltage Detect Pin
3	GND	GND Pin
4	N.C	No Connection
5	N.C	No Connection

PST81XXRX, PST82XXRX (SSON-4A)

Pin No.	Pin name	Functions
1	OUT	Reset Signal Output Pin
2	GND	GND Pin
3	N.C	No Connection
4	V _{DD}	V _{DD} Pin / Voltage Detect Pin

PST81XXUX, PST82XXUX (SC-82ABA/-82ABB)

Pin No.	Pin name	Functions
1	OUT	Reset Signal Output Pin
2	V _{DD}	V _{DD} Pin / Voltage Detect Pin
3	N.C	No Connection
4	GND	GND Pin

Absolute Maximum Ratings

■ PST81XX

Item	Symbol	Ratings	Units
Supply voltage	$V_{DD\ max}$	-0.3~+12.0	V
Output voltage	OUT	-0.3~($V_{DD}+0.3$)	V
Input current (V_{DD})	I_{DD}	20	mA
Output current (RESET, \overline{RESET})	I_{OUT}	20	mA
Operating temperature	T_{OPR}	-40~+105	°C
Storage temperature	T_{STG}	-65~+150	°C

■ PST82XX

Item	Symbol	Ratings	Units
Supply voltage	$V_{DD\ max}$	-0.3~+12.0	V
Output voltage	OUT	-0.3~+12.0	V
Input current (V_{DD})	I_{DD}	20	mA
Output current (RESET, \overline{RESET})	I_{OUT}	20	mA
Operating temperature	T_{OPR}	-40~+105	°C
Storage temperature	T_{STG}	-65~+150	°C

Recommended Operating Conditions

Item	Symbol	Ratings	Units
Operating temperature	T_{OPR}	-40~+105	°C
Supply voltage	V_{DD}	+0.7~+10.0	V

Electrical Characteristics (Except where noted otherwise Ta=25°C)

PST81XX

Item	Symbol	Measurement conditions	Min.	Typ.	Max.	Units	Circuit
Supply current	I _{DD}	V _{DD} =V _{TH} +1V		0.25	1.0	μA	(1)
Reset threshold	V _{TH}	Ta=+25°C V _{TH} ≤ 1.9V	V _{TH} -0.8%	V _{TH}	V _{TH} +0.8%	V	(2)
		Ta=-40~+85°C (note1)	V _{TH} -2.5%	0.8~	V _{TH} +2.5%		
		Ta=+25°C V _{TH} ≥ 2.0V	V _{TH} +0.5%	6.0V	V _{TH} +0.5%		
		Ta=-40~+85°C (note1)	V _{TH} -2.5%	(0.1Vstep)	V _{TH} +2.5%		
Reset threshold hysteresis	ΔV _{TH}	V _{DD} =0V → V _{TH} +1V → 0V	V _{TH} ×0.03		V _{TH} ×0.08	V	(2)
Reset threshold temp. coefficient	ΔV _{TH} /°C	Ta=-40~+85°C (note1)		±100		ppm/°C	(2)
L transfer delay time	t _{PHL}	V _{DD} =V _{TH} +0.4V → V _{TH} -0.4V (note2)			100	μs	(5)
H transfer delay time	t _{PLH}	V _{DD} =V _{TH} -0.4V → V _{TH} +0.4V (note2)			100	μs	(5)
"L" output curren	I _{OL1}	V _{DD} =0.7V, V _{DS} =0.05V	0.01	0.10		mA	(3)
	I _{OL2}	V _{DD} =1.2V, V _{DS} =0.5V V _{TH} > 1.3V	0.23	2.00			
	I _{OL3}	V _{DD} =2.4V, V _{DS} =0.5V V _{TH} > 2.5V	1.60	8.00			
	I _{OL4}	V _{DD} =3.6V, V _{DS} =0.5V V _{TH} > 3.7V	3.20	12.0			
"H" output current	I _{OH1}	V _{DD} =4.8V, V _{DS} =0.5V, V _{TH} < 4.7V	0.36	0.62		mA	(4)
	I _{OH2}	V _{DD} =6.1V, V _{DS} =0.5V, V _{TH} < 5.9V	0.46	0.75			

note1 : This device is tested at Ta=25°C, over temperature limits guaranteed by design only.

note2 : The parameter is guaranteed by design.

PST82XX

Item	Symbol	Measurement conditions	Min.	Typ.	Max.	Units	Circuit
Supply current	I _{DD}	V _{DD} =V _{TH} +1V		0.25	1.0	μA	(1)
Reset threshold	V _{TH}	Ta=+25°C V _{TH} ≤ 1.9V	V _{TH} -0.8%	V _{TH}	V _{TH} +0.8%	V	(2)
		Ta=-40~+85°C (note1)	V _{TH} -2.5%	0.8~	V _{TH} +2.5%		
		Ta=+25°C V _{TH} ≥ 2.0V	V _{TH} +0.5%	6.0V	V _{TH} +0.5%		
		Ta=-40~+85°C (note1)	V _{TH} -2.5%	(0.1Vstep)	V _{TH} +2.5%		
Reset threshold hysteresis	ΔV _{TH}	V _{DD} =0V → V _{TH} +1V → 0V	V _{TH} ×0.03		V _{TH} ×0.08	V	(2)
Reset threshold temp. coefficient	ΔV _{TH} /°C	Ta=-40~+85°C (note1)		±100		ppm/°C	(2)
L transfer delay time	t _{PHL}	V _{DD} =V _{TH} +0.4V → V _{TH} -0.4V (note2)			100	μs	(4)
H transfer delay time	t _{PLH}	V _{DD} =V _{TH} -0.4V → V _{TH} +0.4V (note2)			100	μs	(4)
"L" output curren	I _{OL1}	V _{DD} =0.7V, V _{DS} =0.05V	0.01	0.10		mA	(3)
	I _{OL2}	V _{DD} =1.2V, V _{DS} =0.5V V _{TH} > 1.3V	0.23	2.00			
	I _{OL3}	V _{DD} =2.4V, V _{DS} =0.5V V _{TH} > 2.5V	1.60	8.00			
	I _{OL4}	V _{DD} =3.6V, V _{DS} =0.5V V _{TH} > 3.7V	3.20	12.0			
Output leakage current	I _{reak}	V _{DD} =10V, OUT=10V			0.1	μA	(3)

note1 : This device is tested at Ta=25°C, over temperature limits guaranteed by design only.

note2 : The parameter is guaranteed by design.

Measuring Circuit

PST81XX ★①-③ in the circuit diagram is pin number for the SOT-25A package.

(1) I_{DD}

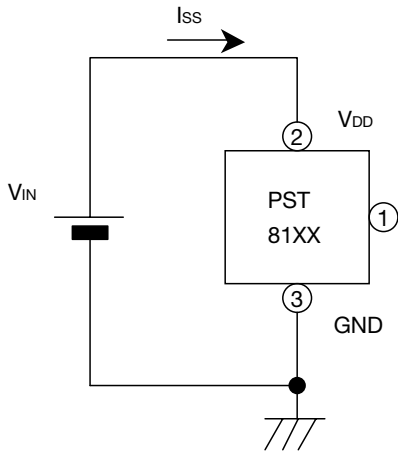

(2) V_{TH}, ΔV_{TH}, ΔV_{TH}/°C

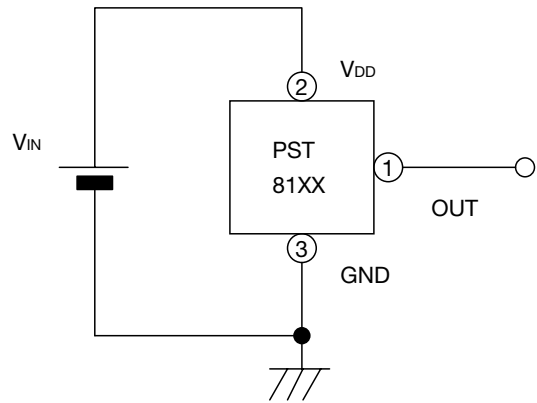

(3) I_{OL1}, I_{OL2}, I_{OL3}, I_{OL4}

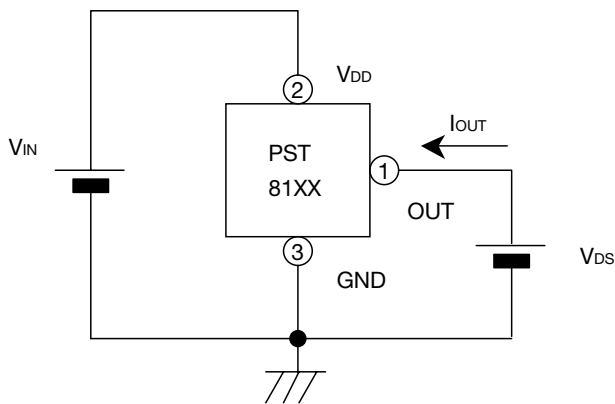

(4) I_{OH1}, I_{OH2}

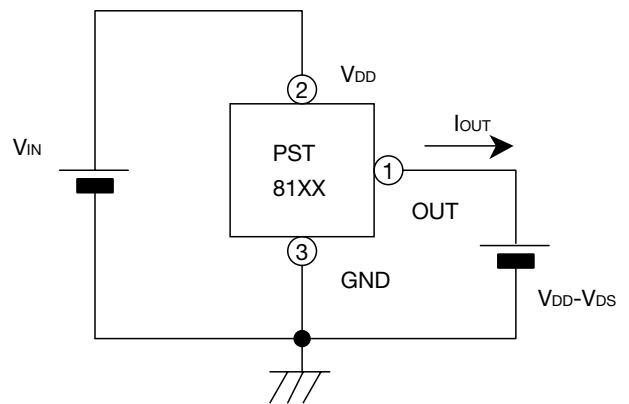

(5) t_{PLH}, t_{PHL}

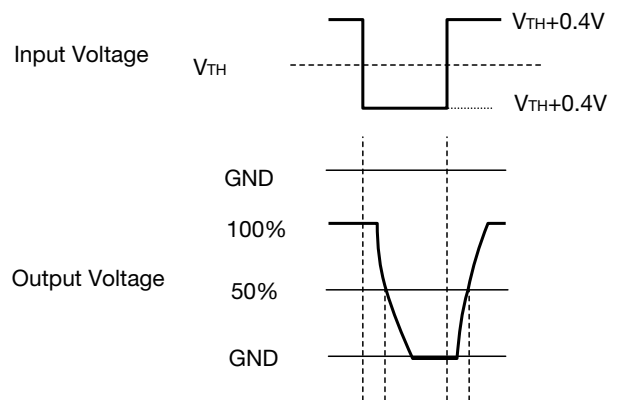
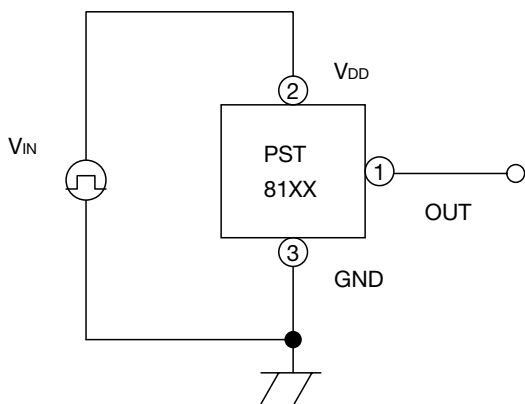

■ PST81XX ★①-③ in the circuit diagram is pin number for the SOT-25A package.

(1) I_{DD}

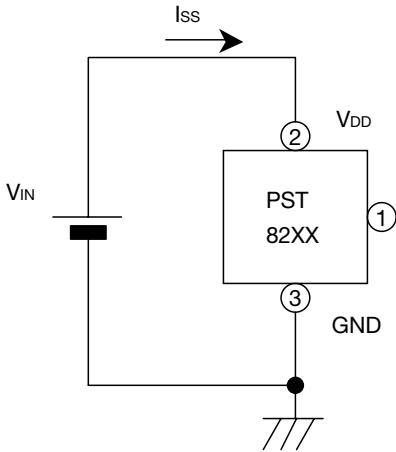

(2) V_{TH} , ΔV_{TH} , $\Delta V_{TH}/^{\circ}C$

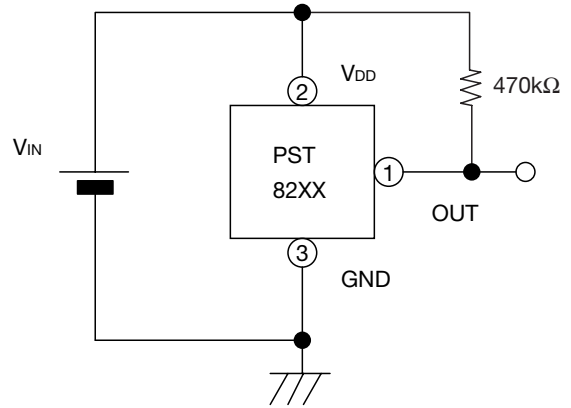

(3) I_{OL1} , I_{OL2} , I_{OL3} , I_{OL4} , I_{reak}

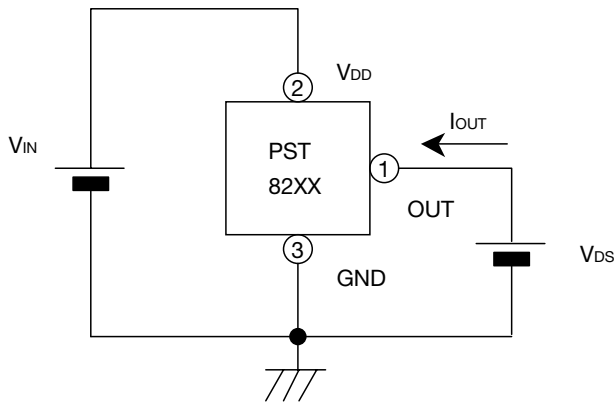

(4) t_{PLH} , t_{PHL}

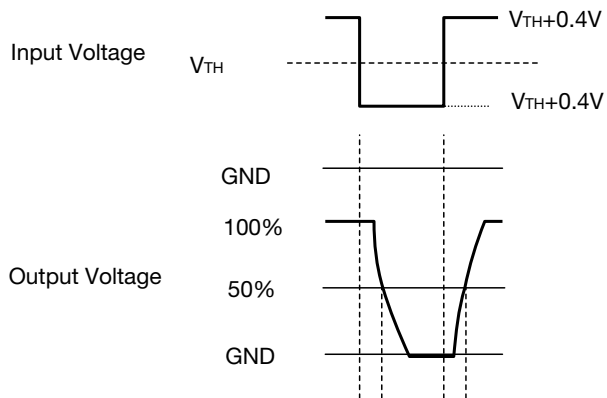
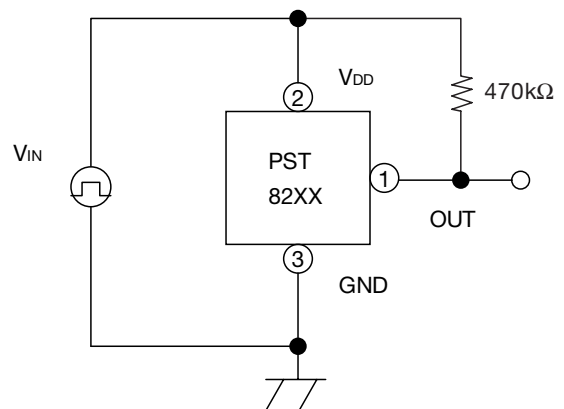

Timing Chart

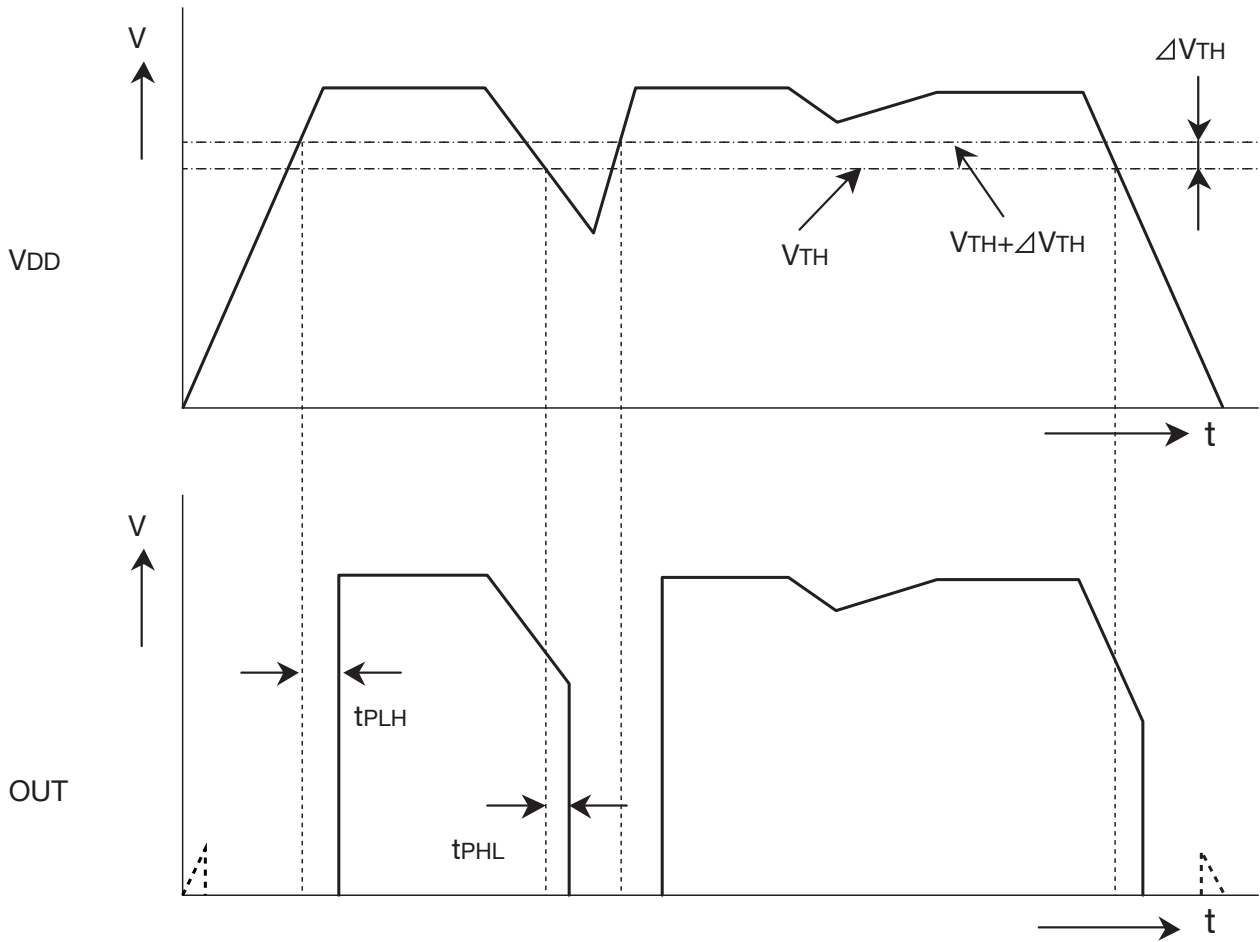

Application Circuit

PST81XX

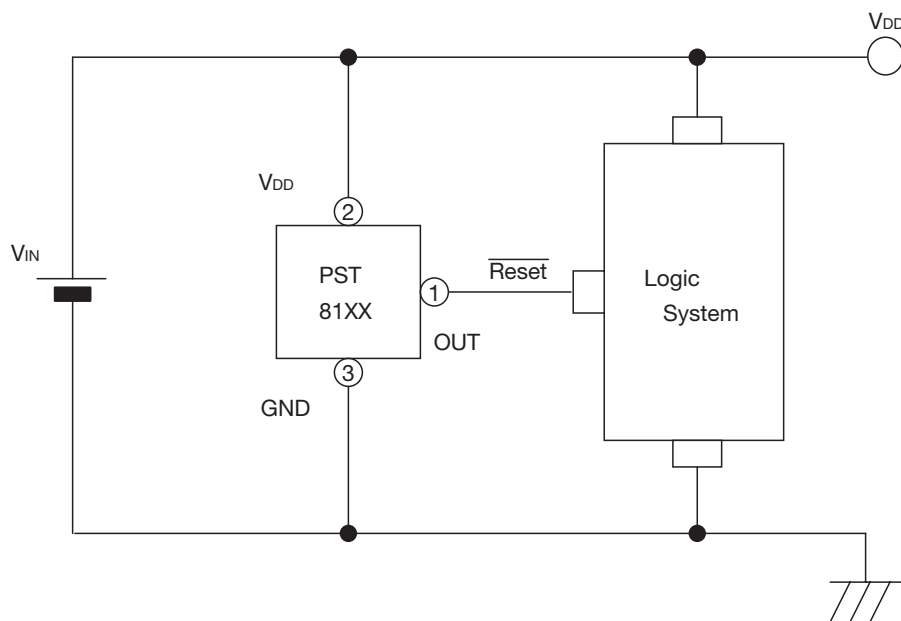

■ PST82XX

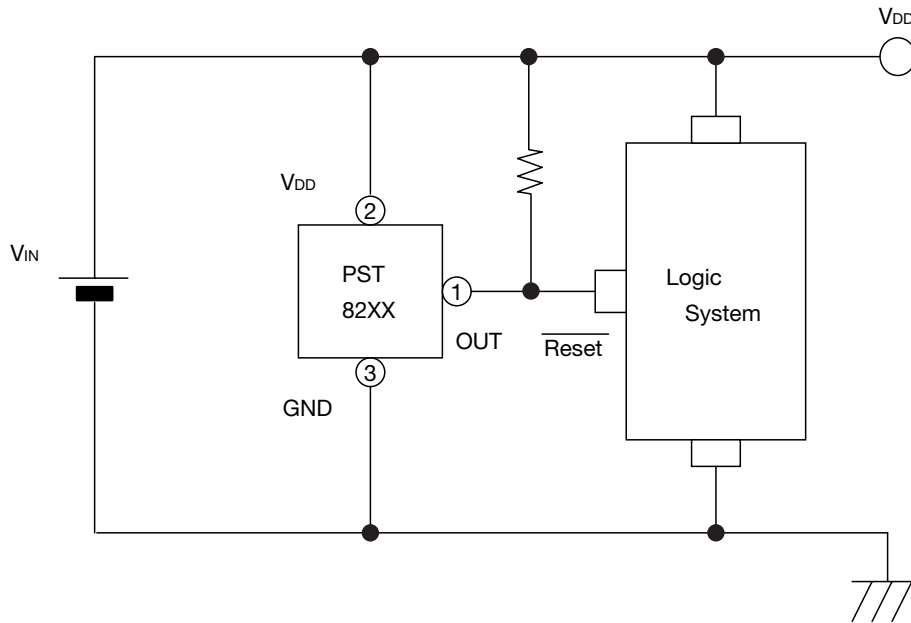

- We shall not be liable for any trouble or damage caused by using this circuit.
- In the event a problem which may affect industrial property or any other rights of us or a third party is encountered during the use of information described in these circuit, Mitsumi Electric Co., Ltd. shall not be liable for any such problem, nor grant a license therefore.

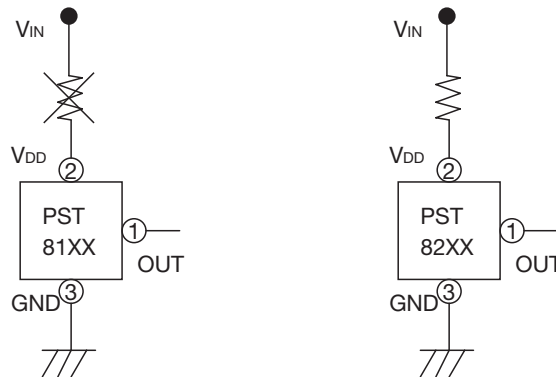

- Please note that there is any possibility of circuit oscillation when resistance put in the line V_{IN} .
- Please do not put resistance for PST81XX.
- Recommend 15k Ω or less for PST82XX.