

## Basic Board Mount Pressure Sensors: NBP Series— Uncompensated/Unamplified 1 Bar to 10 Bar [15 psi to 150 psi]



### DESCRIPTION

Honeywell's Basic Board Mount Pressure Sensors: NBP Series—Uncompensated/Unamplified are designed for customers who require a simple, cost-effective, basic performance, mV output, unamplified, uncompensated, high quality, high resolution solution for medical and industrial applications.

These unamplified and uncompensated sensors offer infinite resolution of the pressure signal. They will operate as specified from -40 °C to 125 °C [-40 °F to 257 °F].

The NBP Series is ideal for those customers who want to do their own compensation, calibration, and amplification in order to make use of the maximum resolution of the bare sensor output, leveraging a custom algorithm required for the application.

### VALUE TO CUSTOMERS

- **Cost-effective:** These devices provide a cost-effective pressure sensing solution with a variety of options that allow customers to meet their specific application needs
- **Honeywell brand:**
  - **Manufacturing excellence:** Honeywell has more than 100 years of manufacturing and engineering excellence
  - **Fast Request for Quotes (RFQs):** Responding quickly to your RFQs and product sample needs is a hallmark of Honeywell. Our experienced engineers understand the importance of timely quotes. And because Honeywell is a manufacturer, you can depend on a quick response to your prototype needs.
  - **Fast response for samples:** Dedicated teams and manufacturing processes ensure that product samples are shipped quickly and delivered in time to support your demanding product development cycle
- **Reliable supply chain:** Honeywell's effective inventory management and dependable supply chain is there throughout your development cycle
- **Designed to Six Sigma standards:** Six Sigma standards provide the highest level of product quality, performance, and consistency. Six Sigma provides confidence that the sensor will perform to specification. Many competitive products are produced to lower Sigma tolerances, which may result in some products not performing to the specification to which they were designed.
- **Supporting documentation:** Honeywell's website provides numerous technical materials to assist you in your application needs

Additionally, the NBP Series offers several package styles and mounting options, making it easier for device manufacturers to integrate the product into their applications.

The NBP Series measures absolute and gage pressures. The absolute versions have an internal vacuum reference and an output value proportional to absolute pressure. Gage versions are referenced to atmospheric pressure and provide an output proportional to pressure variations from atmosphere.

The NBP Series sensors are intended for use with non-corrosive, non-ionic gases, such as air and other dry gases and for non-corrosive, non-ionic liquids. All products are designed and manufactured according to ISO 9001.

# Basic Board Mount Pressure Sensors: NBP Series— Uncompensated/Unamplified

## FEATURES AND BENEFITS

- **Small Size:** Package size (as small as 7 mm x 7 mm [0.276 in x 0.276 in]) is very small when compared to most board mount pressure sensors, occupying less space on the PCB and typically allowing for easy placement on crowded PCBs or in small devices
- **Durable:** Many features allow for use in tough environments, including:
  - Wide operating temperature range from -40 °C to 125 °C [-40 °F to 257 °F]
  - Media compatibility options:
    - Non-gel coating: The input port is limited to non-corrosive, non-ionic media such as dry air and gases and should not be exposed to condensation; the gases are limited to media that are compatible with high temperature polyamide, silicone, alumina ceramic, silicon, gold, and glass
    - Gel coating: Uses the same materials in the wetted media path but is protected from condensation by a silicone-based gel coating; allows use in applications where condensation can occur

– ISO 9001 compliance

- **Flexible:** Numerous package styles, pressure ranges, housings, gel coating, and porting options simplify integration into the device manufacturer's application
- **Robust:** Reflow mounting J-STD-020D, MSL 1 and rapid stabilization after reflow soldering allow calibration immediately after mounting

## POTENTIAL APPLICATIONS

### Medical:

- Hospital beds
- Oxygen concentrators
- Wound therapy
- Blood pressure monitoring

### Industrial:

- HVAC Transmitters
- Air movement control
- Environmental control
- Level indicators
- Leak detection
- Industrial controls
- Pneumatic controls
- Other commercial applications

**Table 1. Absolute Maximum Ratings<sup>1</sup>**

Parameter	Min.	Max.	Unit
Supply voltage ( $V_{supply}$ )	-12.0	12.0	Vdc
ESD susceptibility (human body model)	2	–	kV
Storage temperature	-40 [-40]	125 [257]	°C [°F]
Soldering time and temperature: lead solder temperature (DIP) peak reflow temperature (Leadless SMT, SMT)	4 s max. at 250 °C [482 °F] 15 s max. at 250 °C [482 °F]		

**Table 2. Operating Specifications**

Parameter	Min.	Typ.	Max.	Unit
Supply voltage ( $V_{supply}$ ) <sup>2</sup>	1.8	5.0 <sup>3</sup>	12.0	Vdc
Supply current (at 5.0 Vdc supply)	–	1.5	2.5	mA
Specified temperature range <sup>4</sup>	-40 [-40]	–	125 [257]	°C [°F]
Accuracy <sup>5</sup>	–	–	±0.25	%FSS BFSL <sup>6</sup>
Input resistance	2.4	3.0	5.5	kOhm
Thermal effect on resistance (TCR) <sup>7</sup>	1200	–	3200	ppm/°C

**Table 3. Environmental Specifications**

Parameter	Characteristic
Humidity: all external surfaces internal surfaces of gel coating option internal surfaces of non-gel coating option	0 %RH to 95 %RH, non-condensing 0 %RH to 100 %RH, condensing 0 %RH to 95 %RH, non-condensing
Vibration	MIL-STD-202F, Method 214A, Condition 1E (15 g, 10 Hz to 2 kHz)
Shock	MIL-STD-202F, Method 213B, Condition F (100g, 6 ms duration)
Life <sup>8</sup>	1 million pressure cycles min.
ESD	MIL-STD-883 Method 3015.7, Class 2, 2kV, human body model
Solder reflow	J-STD-020D, MSL 1, unlimited storage life

# 1 Bar to 10 Bar [15 psi to 150 psi]

**Table 4. Wetted Materials<sup>9</sup>**

Parameter	Non-Gel Coating Option	Gel Coating Option
Covers	high temperature polyamide	high temperature polyamide
Substrate	alumina ceramic	silicone gel
Adhesives	epoxy, RTV	epoxy
Electronic components	ceramic, silicon, gold, glass	–

**Notes:**

1. Absolute maximum ratings are the extreme limits the device will withstand without damage.
2. Ratiometricity of the sensor (the ability of the device output to scale to the supply voltage) is achieved within the specified operating voltage.
3. Incorrect application of supply voltage or ground to the wrong pin may cause electrical failure.
4. The specified temperature range is the temperature range over which the sensor will produce an output proportional to pressure within the specified performance limits.
5. Accuracy: The maximum deviation in output from a Best Fit Straight Line (BFSL) fitted to the output measured over the pressure range at 25 °C [77 °F]. Includes all errors due to pressure non-linearity, pressure hysteresis, and non-repeatability.
6. Full Scale Span (FSS) is the algebraic difference between the output signal measured at the maximum and minimum limits of the pressure range. (See Figure 1 for ranges.)
7. TCR (Thermal Effect on Resistance): The deviation in input resistance due to change in temperature over the specified temperature range, relative to input resistance measured at °C.
8. Life may vary depending on specific application in which sensor is utilized.
9. Contact Honeywell Customer Service for detailed material information.

**CAUTION**

**MISUSE OF GEL COATING OPTION**

- Non-gel coating option: The input port is limited to non-corrosive, non-ionic media such as dry air and gases and should not be exposed to condensation. The gases are limited to media that are compatible with the following wetted materials of construction: high temperature polyamide, silicone, alumina ceramic, silicon, gold, and glass.
- Gel coating option: The gel coated sensors use the same materials in the wetted media path but are protected from condensation by a silicone-based gel coating. The gel coating option allows use in applications where condensation can occur.

**Failure to comply with these instructions may result in product damage.**

**Figure 1. Nomenclature and Order Guide**

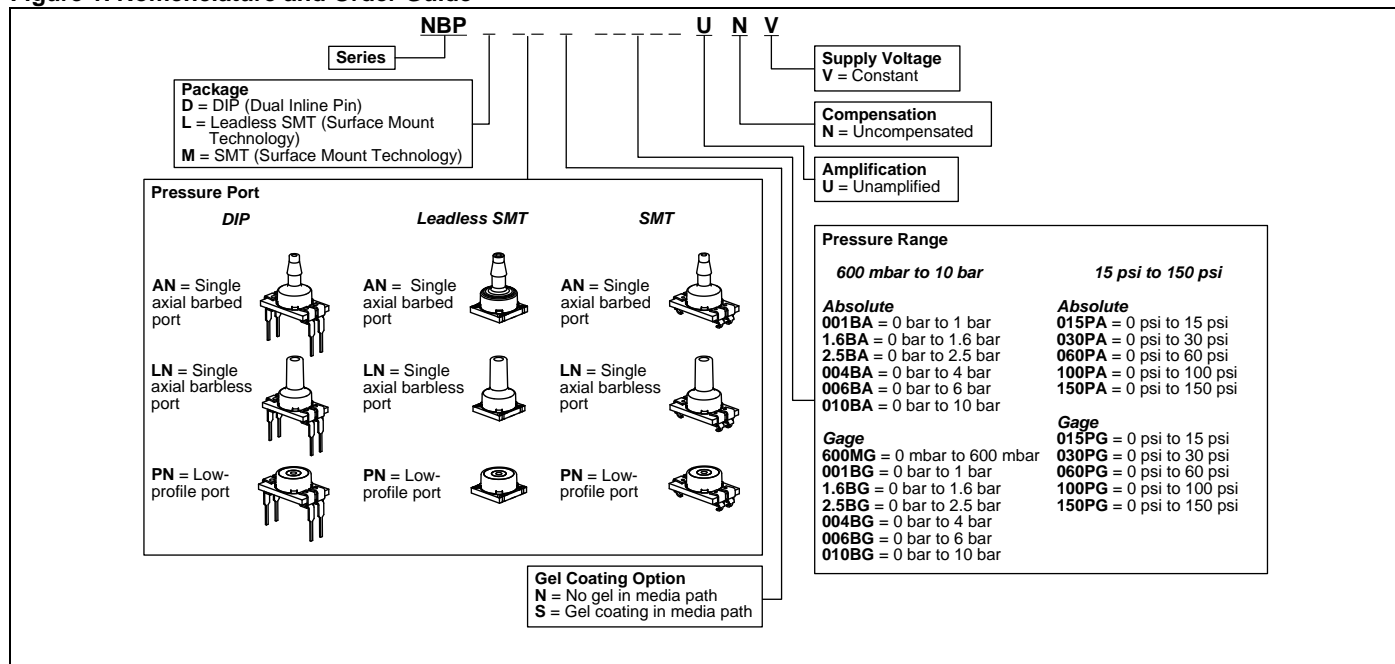

**Note:** See Table 7 for an explanation of sensor pressure types.

# NBP Series–Uncompensated/Unamplified

Figure 2. Completed Catalog Listing Example

<p><b>NBPDANN100PGUNV</b> DIP package, AN pressure port, non-gel coating option, 100 psi gage</p>	
---	---

Table 5. Pressure Range Specifications for 600 mbar to 10 bar

Pressure Range (see Figure 1)	Pressure Range		Unit	Over Pressure	Burst Pressure	Offset <sup>10</sup> (mV/V)		Sensitivity (mV/V/Full Scale Span)			TCO <sup>11</sup> (%FSS/25 °C)			TCS <sup>12</sup> (%FSS/25 °C)		
	Pmin.	Pmax.				Min.	Max.	Min.	Nom.	Max.	Min.	Nom.	Max.	Min.	Nom.	Max.
<b>Absolute</b>																
001BA	0	1	bar	2	4	-7.0	7.0	10.0	15.0	20.0	-1.5	0.0	1.5	-6.0	-5.0	-3.8
1.6BA	0	1.6	bar	4	8	-7.0	7.0	12.0	16.0	20.0	-1.5	0.0	1.5	-6.0	-5.0	-3.8
2.5BA	0	2.5	bar	4	8	-7.0	7.0	18.8	25.0	31.3	-1.5	0.0	1.5	-6.0	-5.0	-3.8
004BA	0	4	bar	8	16	-7.0	7.0	16.8	20.0	23.2	-1.5	0.0	1.5	-6.0	-5.0	-3.8
006BA	0	6	bar	16	20	-7.0	7.0	12.6	15.0	17.4	-1.75	0.0	1.75	-6.0	-5.0	-3.8
010BA	0	10	bar	16	20	-7.0	7.0	21.0	25.0	29.0	-1.5	0.0	1.5	-6.0	-5.0	-3.8
<b>Gage</b>																
600MG	0	600	mba	2000	4000	-7.0	7.0	6.0	9.0	12.0	-2.5	-1.0	2.5	-6.0	-5.0	-3.8
001BG	0	1	bar	2	4	-7.0	7.0	10.0	15.0	20.0	-1.5	-0.5	1.5	-6.0	-5.0	-3.8
1.6BG	0	1.6	bar	4	8	-7.0	7.0	12.0	16.0	20.0	-1.5	-0.5	1.5	-6.0	-5.0	-3.8
2.5BG	0	2.5	bar	4	8	-7.0	7.0	18.8	25.0	31.3	-1.0	-0.3	1.0	-6.0	-5.0	-3.8
004BG	0	4	bar	8	16	-7.0	7.0	16.8	20.0	23.2	-1.0	-0.3	1.0	-6.0	-5.0	-3.8
006BG	0	6	bar	16	20	-7.0	7.0	12.6	15.0	17.4	-1.5	-0.4	1.5	-6.0	-5.0	-3.8
010BG	0	10	bar	16	20	-7.0	7.0	21.0	25.0	29.0	-1.0	-0.3	1.0	-6.0	-5.0	-3.8

Table 6. Pressure Range Specifications for 15 psi to 150 psi

Pressure Range (see Figure 1)	Pressure Range		Unit	Over Pressure	Burst Pressure	Offset <sup>10</sup> (mV/V)		Sensitivity (mV/V/Full Scale Span)			TCO <sup>11</sup> (%FSS/25 °C)			TCS <sup>12</sup> (%FSS/25 °C)		
	Pmin.	Pmax.				Min.	Max.	Min.	Nom.	Max.	Min.	Nom.	Max.	Min.	Nom.	Max.
<b>Absolute</b>																
015PA	0	15	psi	30	60	-7.0	7.0	10.3	15.0	20.7	-1.5	-0.6	1.5	-6.0	-5.0	-3.8
030PA	0	30	psi	60	120	-7.0	7.0	15.5	21.0	26.0	-1.0	-0.4	1.0	-6.0	-5.0	-3.8
060PA	0	60	psi	120	240	-7.0	7.0	17.4	21.0	24.0	-1.0	-0.3	1.0	-6.0	-5.0	-3.8
100PA	0	100	psi	240	300	-7.0	7.0	14.5	17.2	20.0	-1.0	0.4	1.0	-6.0	-5.0	-3.8
150PA	0	150	psi	240	300	-7.0	7.0	21.7	26.0	30.0	-1.0	0.3	1.0	-6.0	-5.0	-3.8
<b>Gage</b>																
015PG	0	15	psi	30	60	-7.0	7.0	10.3	15.0	20.7	-1.5	-0.6	1.5	-6.0	-5.0	-3.8
030PG	0	30	psi	60	120	-7.0	7.0	15.5	21.0	26.0	-1.0	-0.4	1.0	-6.0	-5.0	-3.8
060PG	0	60	psi	120	240	-7.0	7.0	17.4	21.0	24.0	-1.0	-0.3	1.0	-6.0	-5.0	-3.8
100PG	0	100	psi	240	300	-7.0	7.0	14.5	17.2	20.0	-1.0	0.4	1.0	-6.0	-5.0	-3.8
150PG	0	150	psi	240	300	-7.0	7.0	21.7	26.0	30.0	-1.0	0.3	1.0	-6.0	-5.0	-3.8

**Notes:**

- Offset: The output signal obtained when the reference pressure is applied to all available pressure ports. Also known as “null” or “zero”.
- TCO (Thermal Effect on Offset): The deviation in offset due to changes in temperature over the specified temperature range, relative to offset measured at 25 °C.
- TCS (Thermal Effect on Span): The deviation in full scale span due to changes in temperature over the specified temperature range, relative to full scale span measured at 25 °C.

# 1 Bar to 10 Bar [15 psi to 150 psi]

**Table 7. Pressure Types**

Pressure Type	Description
Absolute	Output is proportional to the difference between applied pressure and a built-in reference to vacuum. Reference pressure is absolute zero pressure (full vacuum).
Gage	Output is proportional to the difference between applied pressure and atmospheric (ambient) pressure. Reference pressure is atmospheric pressure.

**Table 8. Pinout for DIP and SMT Packages**

Pin 1	Pin 2	Pin 3	Pin 4
Vsupply	Vout-	GND	Vout+

**Table 9. Pinout for Leadless SMT Pressure Packages**

Pad 1	Pad 2	Pad 3	Pad 4	Pad 5	Pad 6
Vsupply	NC	Vout-	GND	NC	Vout+

**Figure 3. DIP Package Dimensional Drawings (For reference only: mm [in])**

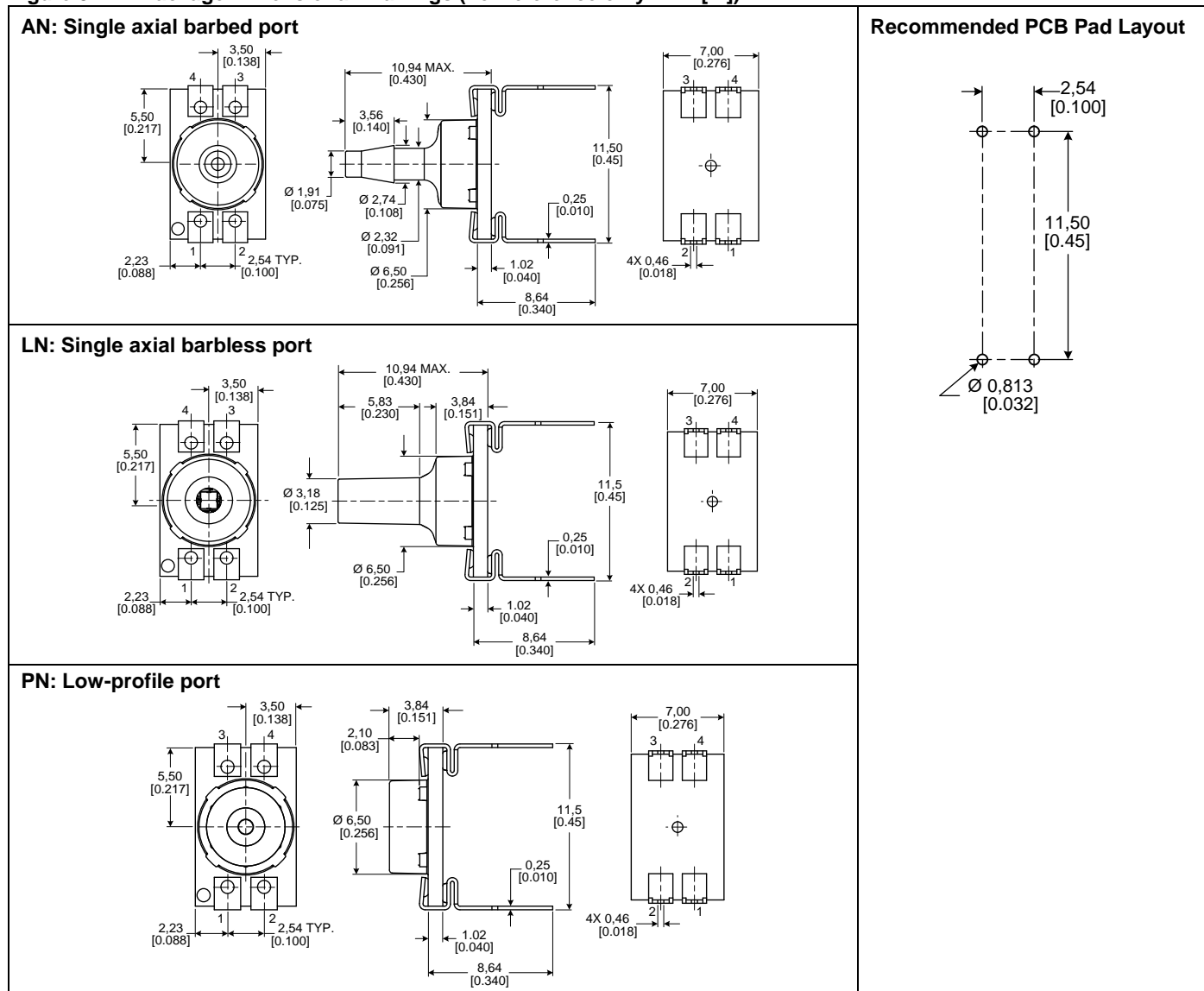

# NBP Series—Uncompensated/Unamplified

Figure 4. Leadless SMT Package Dimensional Drawings (For reference only: mm [in])

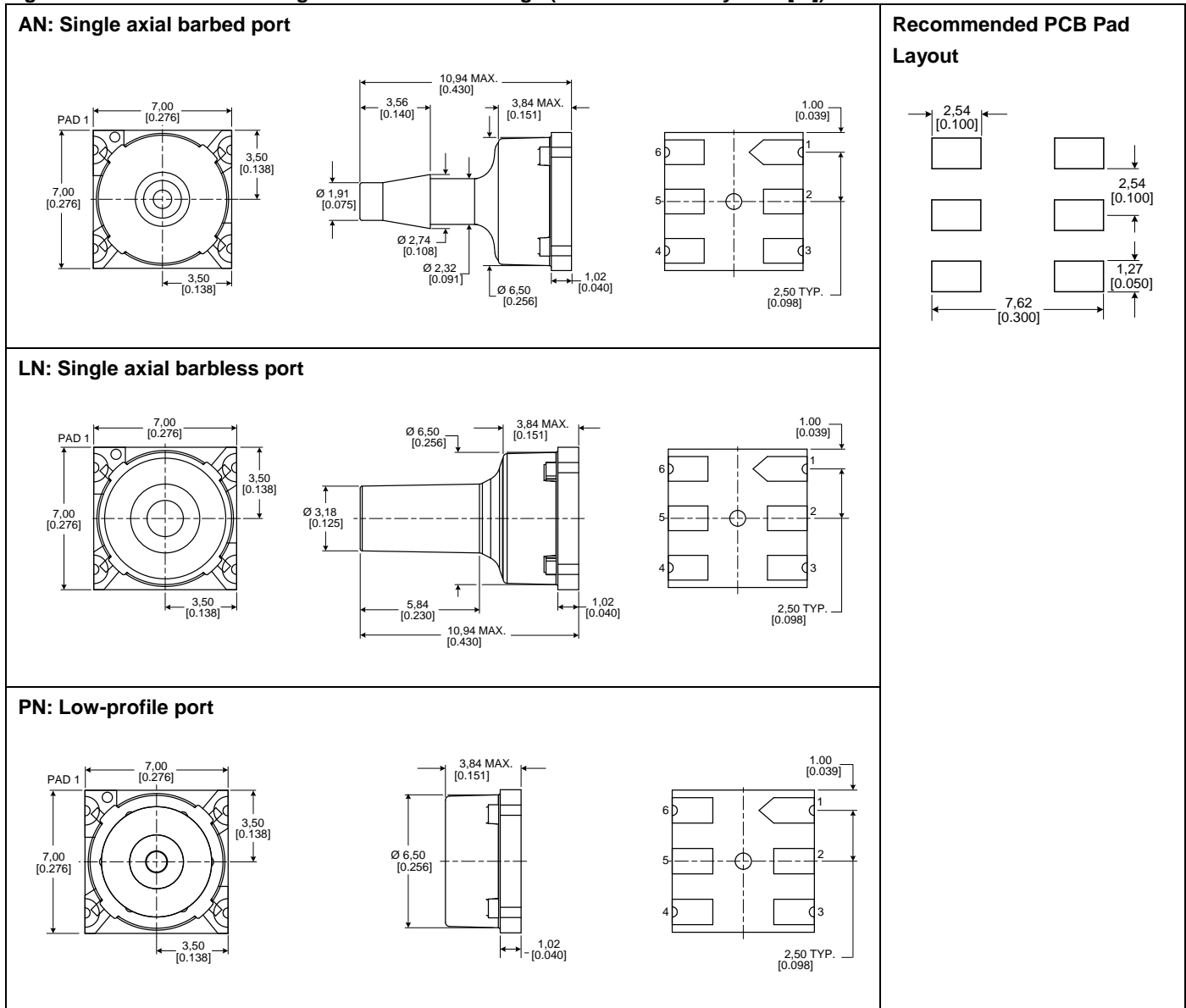

# 1 Bar to 10 Bar [15 psi to 150 psi]

**Figure 5. SMT Package Dimensional Drawings (For reference only: mm [in])**

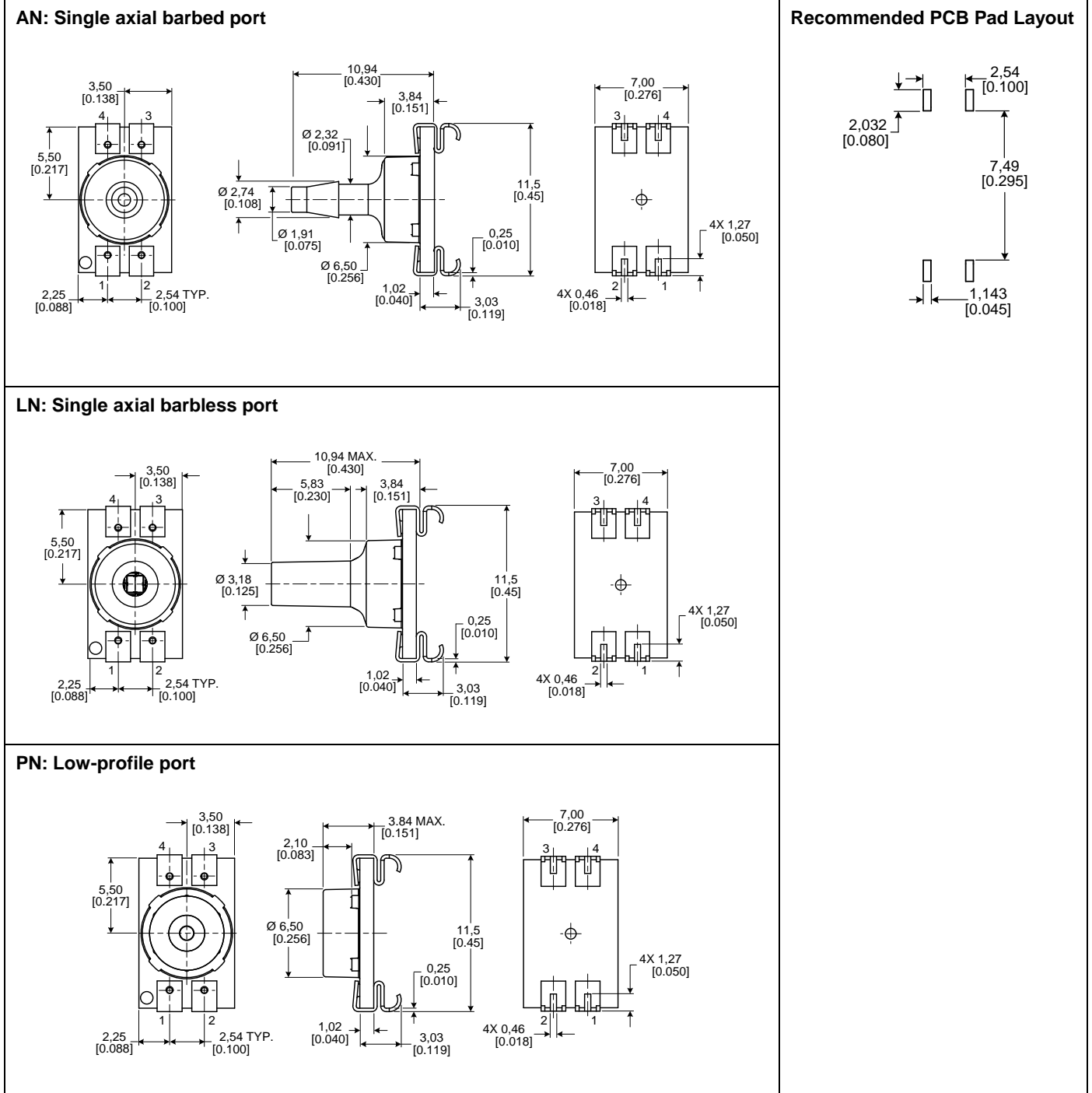

## **WARNING**

### **PERSONAL INJURY**

DO NOT USE these products as safety or emergency stop devices or in any other application where failure of the product could result in personal injury.

**Failure to comply with these instructions could result in death or serious injury.**

### **WARRANTY/REMEDY**

Honeywell warrants goods of its manufacture as being free of defective materials and faulty workmanship. Honeywell's standard product warranty applies unless agreed to otherwise by Honeywell in writing; please refer to your order acknowledgement or consult your local sales office for specific warranty details. If warranted goods are returned to Honeywell during the period of coverage, Honeywell will repair or replace, at its option, without charge those items it finds defective. **The foregoing is buyer's sole remedy and is in lieu of all other warranties, expressed or implied, including those of merchantability and fitness for a particular purpose. In no event shall Honeywell be liable for consequential, special, or indirect damages.**

While we provide application assistance personally, through our literature and the Honeywell web site, it is up to the customer to determine the suitability of the product in the application.

Specifications may change without notice. The information we supply is believed to be accurate and reliable as of this printing. However, we assume no responsibility for its use.

## **WARNING**

### **MISUSE OF DOCUMENTATION**

- The information presented in this product sheet is for reference only. DO NOT USE this document as a product installation guide.
- Complete installation, operation, and maintenance information is provided in the instructions supplied with each product.

**Failure to comply with these instructions could result in death or serious injury.**

### **SALES AND SERVICE**

Honeywell serves its customers through a worldwide network of sales offices, representatives and distributors. For application assistance, current specifications, pricing or name of the nearest Authorized Distributor, contact your local sales office or:

**E-mail:** [info.sc@honeywell.com](mailto:info.sc@honeywell.com)

**Internet:** [www.honeywell.com/sensing](http://www.honeywell.com/sensing)

### **Phone and Fax:**

Asia Pacific	+65 6355-2828 +65 6445-3033 Fax
Europe	+44 (0) 1698 481481 +44 (0) 1698 481676 Fax
Latin America	+1-305-805-8188 +1-305-883-8257 Fax
USA/Canada	+1-800-537-6945 +1-815-235-6847 +1-815-235-6545 Fax

Sensing and Control  
Honeywell  
1985 Douglas Drive North  
Golden Valley, MN 55422  
[www.honeywell.com/sensing](http://www.honeywell.com/sensing)

008243-1-EN  
July 2012  
© 2012 Honeywell International Inc.

# Honeywell