

THIS DRAWING IS UNPUBLISHED. RELEASED FOR PUBLICATION, 19 .
 © COPYRIGHT 19 BY AMP INCORPORATED. ALL INTERNATIONAL RIGHTS RESERVED.

LOC	DIST	P	F	REVISIONS			
ZONE	LTR	DESCRIPTION	DATE	APPD			
G	14			B	REVISED PER 0720-0937-96	05JUN96	OKS MJS

METRIC
 DIMENSIONS LISTED IN mm [INCHES]

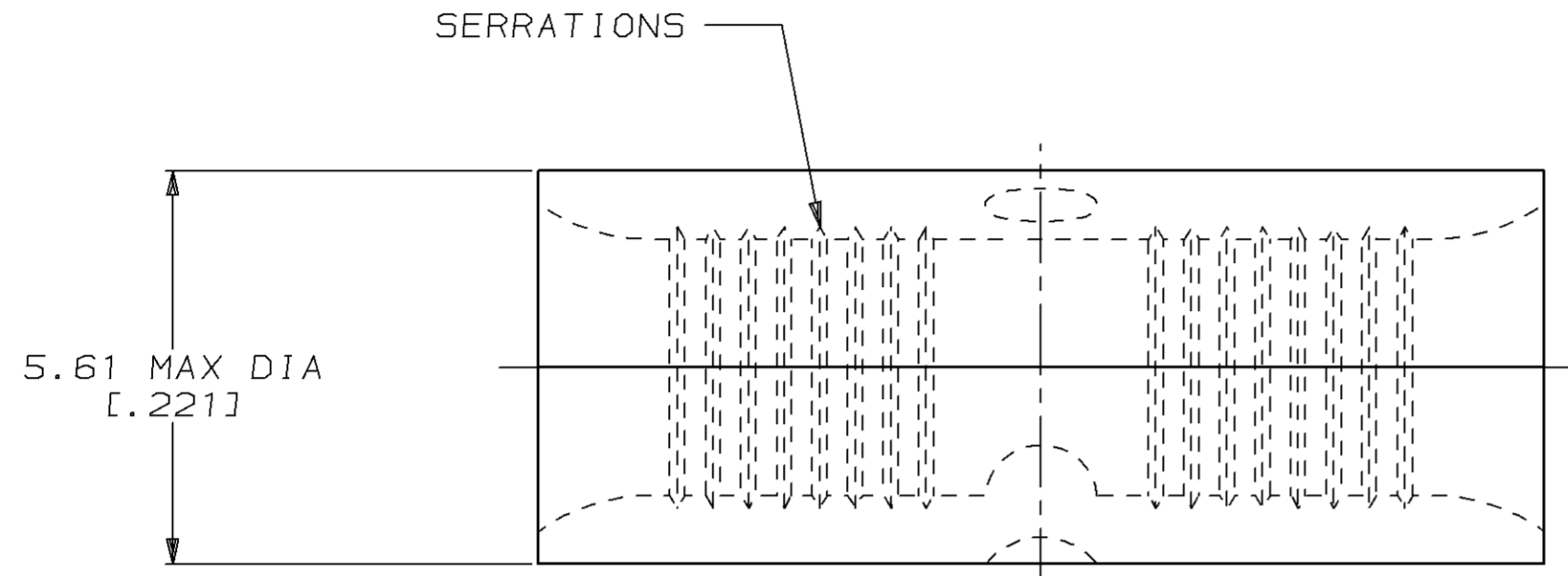

AMP WIRE RANGE	UL E13288 Listed
12-10 AWG STRANDED	12-10 AWG STRANDED
SP LR7189 Certified	MILITARY P/N AND CLASS
NOT CERTIFIED	NOT APPLICABLE

- ① STAMP AMP 12-10* APPROX AS SHOWN
- ② MAXIMUM LENGTH DOES NOT INCLUDE MANUFACTURING TABS

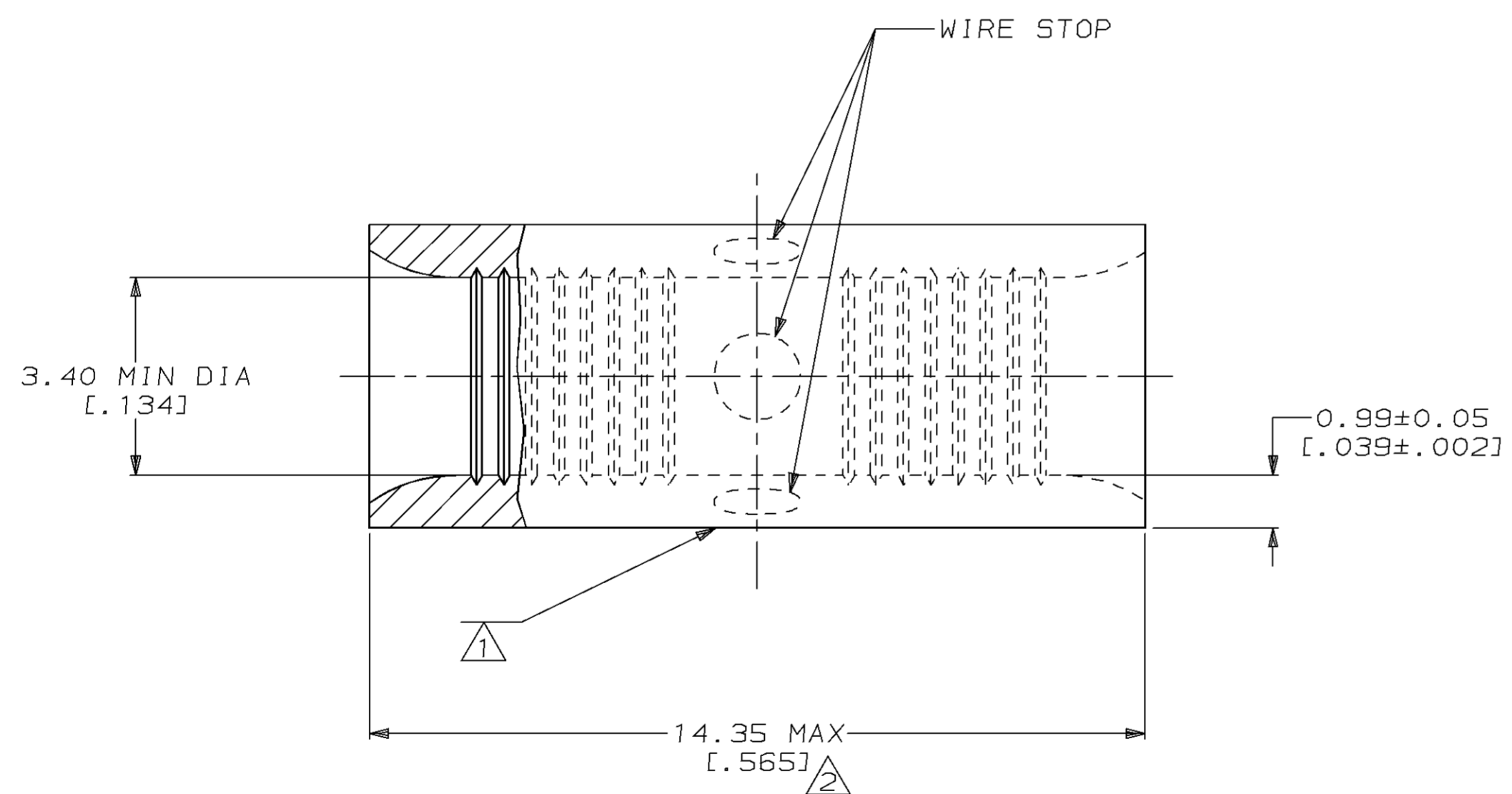

50	LOOSE PIECE, BOX	8-34228-2
-	LOOSE PIECE	34228
QUANTITY	PACKAGE TYPE	PART NO

AMP INCORPORATED
CUSTOMER SERVICE SYSTEMS

FOR ADDITIONAL PRODUCT INFORMATION OR COPIES OF DRAWINGS AND TECHNICAL DOCUMENTS

FOR APPLICATION TOOLING INFORMATION

FOR ORDER ENTRY

PRODUCT INFORMATION CENTER
 1-800-522-6752

TOOLING ASSISTANCE CENTER
 1-800-722-1111

1-800-526-5142

MAX RECOMMENDED OPERATING TEMPERATURE:
 170°C MAX

VOLTAGE RATING:
 NOT APPLICABLE

WIRE CROSS SECTIONAL AREA RANGE:
 2.62-6.64mm² [5,180-13,100] CIR MILS STRANDED

THIS DRAWING IS A CONTROLLED DOCUMENT FOR AMP INCORPORATED. IT IS SUBJECT TO CHANGE AND THE CONTROLLING ENGINEERING ORGANIZATION SHOULD BE CONTACTED FOR THE LATEST REVISION.

DO NOT SCALE PRINT. UNLESS SPECIFIED DIMENSIONS IN mm [INCHES] TOLERANCES ON:

2 PLC DEC ± -
 3 PLC DEC ± -
 ANGLES ± -

MATERIAL
 COPPER PER ASTM B-152 ANNEALED

FINISH
 TIN PLATE 0.00254 [0.00100] MIN THK PER MIL-T-10727

DR 3-1-93
 TA BRINKMAN

CHK 3-1-93
 DA PATTERSON

APPD 3-1-93
 DE MILLER

APPD 3-1-93
 JL MECKLEY

PRODUCT SPEC -

APPLICATION SPEC -

WEIGHT -

AMP AMP Incorporated
 Harrisburg, PA 17105-3608

NAME
**SPLICE, BUTT,
 STANDARD, BUDGET**

SIZE [C] CAGE CODE 00779 DRAWING NO G-34228

SCALE 10:1 SHEET 1 OF 1