

◇ = ASO ONLY (APPLICATION SPECIFIC ORDER)

CQTE-XXX-XX-X-D-DP-XX

No OF POSITIONS  
-014, -028, -042,  
-056, -070  
(PER ROW)

OPTION  
-A: ALIGNMENT PINS  
-LC: LOCKING CLIPS  
(USE LC-08-TM-01)  
BODY STYLE  
-DP: DIFFERENTIAL PAIRS

LEAD STYLE

- 01: .1680 [4.267] (SEE FIG.1)
- 02: .2861 [7.264] (SEE FIG.1)
- 03: .4042 [1.123] (SEE FIG.1)
- 04: .600 [15.24] (SEE FIG. 4, SHT. 3)
- 05: .718 [18.237] (SEE FIG. 4, SHT. 3)
- 06: .835 [21.209] (SEE FIG. 4, SHT. 3)
- 07: .954 [24.232]
- 08: 1.151 [29.24]
- 09: .522 [13.258]
- 10: .5606 [14.239]

ROW SPECIFICATION  
-D: DOUBLE (USE QTE-20-XX-D-XX & QTEH-20-XX-D-XX)

No OF BANKS

PLAIN SPECIFICATION  
-C: ELECTRO-POLISHED REFLECTIVE  
(USE T-15-XXX-C, T-15-1-XX-G)

DO NOT SCALE FROM THIS PRINT

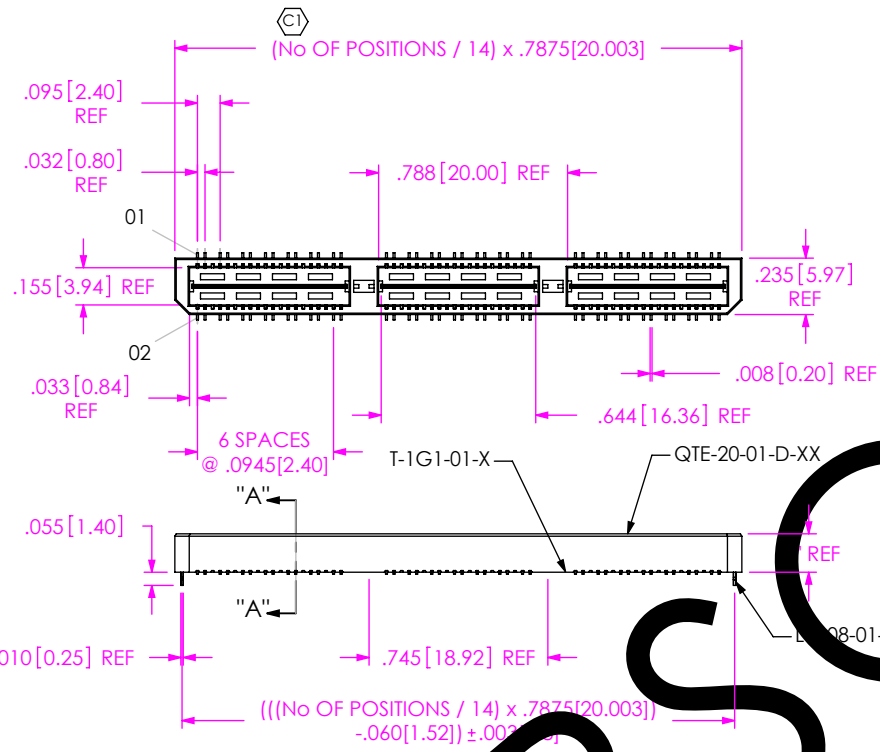

BOBSON LETTERS

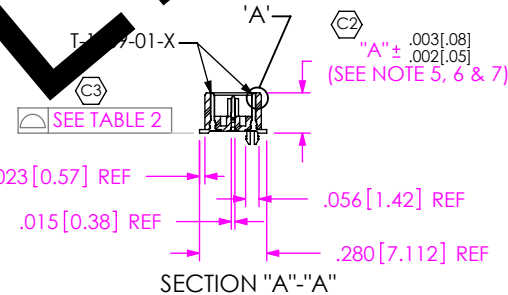

- NOTES:
- ① REPRESENTS A CRITICAL DIMENSION.
  - MINIMUM TERMINAL RETENTION: 5 OZ.
  - MINIMUM GROUND PLANE RETENTION: 1 LB.
  - PARTS TO BE MOLDED TO POSITION.
  - MAXIMUM VARIANCE OF .002 [0.05].
  - DIMENSION APPLIES TO TERMINALS AND GROUND PLANE.
  - GROUND PLANE PRESS HEIGHT MUST BE .003 [0.08] LESS THAN THE MAX HEIGHT OR .001 [0.03] GREATER THAN THE MINIMUM HEIGHT OF THE TERMINALS.

DETAIL 'A'  
SCALE 6 : 1

-LC: LOCKING CLIP OPTION SHOWN

FIG. 1

CQTE-042-01-X-D-DP-LC SHOWN

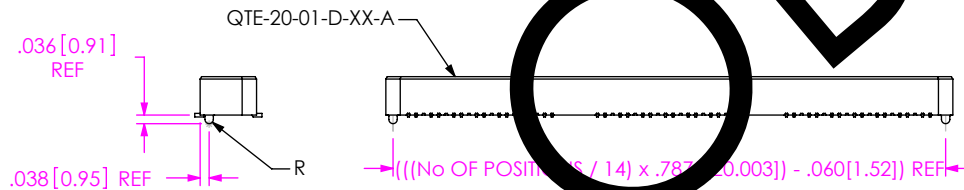

-A: ALIGNMENT PIN OPTION SHOWN  
(STYLES -01, -02 & -03)

TABLE 2	
No OF POSITIONS	COPLANARITY (INCLUDES GROUND PLANE)
-014 THRU -042	.0040 [.10]
-056 THRU -070	.0060 [.15]

TABLE 1						MATED HEIGHT WITH QSE-DP-01
STYLE	"A"	"B"	BODY	GROUND PLANE	TERMINAL	
-01	.1680 [4.267]	.1600 [4.064]	QTE-20-01-D-XX	T-1G1-01-X	T-1S39-01-X	.197 [5.00] REF
-02	.2861 [7.267]	.2781 [7.064]	QTE-20-02-D-XX	T-1G1-02-X	T-1S59-02-X	.315 [8.00] REF
-03	.4042 [10.267]	.3962 [10.063]	QTE-20-03-D-XX	T-1G1-03-X	T-1S39-03-X	.433 [11.00] REF

UNLESS OTHERWISE SPECIFIED, DIMENSIONS ARE IN INCHES. TOLERANCES ARE:  
DECIMALS: .XX: ±.01 [.3]  
.XXX: ±.005 [.13]  
.XXXX: ±.0020 [.051]

PROPRIETARY NOTE  
THIS DOCUMENT CONTAINS INFORMATION CONFIDENTIAL AND PROPRIETARY TO SAMTEC, INC. AND SHALL NOT BE REPRODUCED OR TRANSFERRED TO OTHER DOCUMENTS OR DISCLOSED TO OTHERS OR USED FOR ANY PURPOSE OTHER THAN THAT WHICH IT WAS OBTAINED WITHOUT THE EXPRESSED WRITTEN CONSENT OF SAMTEC, INC.



520 PARK EAST BLVD, NEW ALBANY, IN 47150  
PHONE: 812-944-6733 FAX: 812-948-5047  
e-Mail: info@SAMTEC.com code: 55322

MATERIAL: DO NOT SCALE DRAWING	SHEET SCALE: 1.25:1	DESCRIPTION: .8mm DIFFERENTIAL PAIRS HS TERMINAL ASSEMBLY
INSULATOR: LCP, BLACK TERMINAL: PHOS BRONZE GROUND PLANE: PHOS BRONZE	DWG. NO. CQTE-XXX-XX-X-D-DP-XX	BY: B. COOPER 10/8/2007 SHEET 1 OF 3

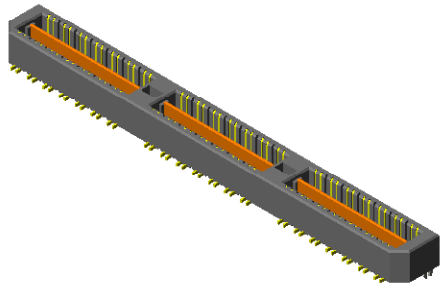

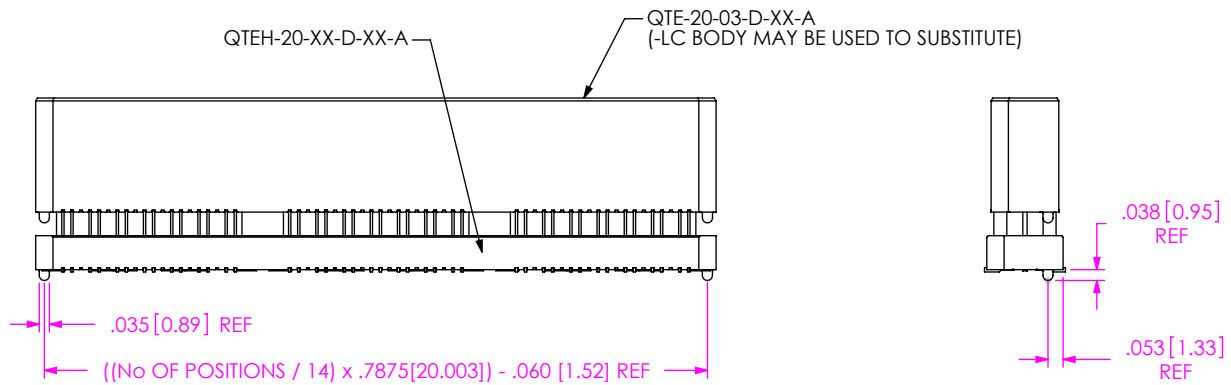

-A: ALIGNMENT PIN OPTION  
 (STYLES -04, -05, -06, -07, -08, -09, -10)

F:\DWG\MISC\MKTG\CQTE-XXX-XX-X-D-DP-XX-MKT.SLDDRW

**PROPRIETARY NOTE**  
 THIS DOCUMENT CONTAINS INFORMATION CONFIDENTIAL AND PROPRIETARY TO SAMTEC, INC. AND SHALL NOT BE REPRODUCED OR TRANSFERRED TO OTHER DOCUMENTS OR DISCLOSED TO OTHERS OR USED FOR ANY PURPOSE OTHER THAN THAT WHICH IT WAS OBTAINED WITHOUT THE EXPRESSED WRITTEN CONSENT OF SAMTEC, INC.

DO NOT SCALE DRAWING

SHEET SCALE: 2:1



520 PARK EAST BLVD, NEW ALBANY, IN 47150  
 PHONE: 812-944-6733 FAX: 812-948-5047  
 e-Mail: info@SAMTEC.com code: 55322

DESCRIPTION:  
 .8mm DIFFERENTIAL PAIRS HS TERMINAL ASSEMBLY

DWG. NO.  
**CQTE-XXX-XX-X-D-DP-XX**

BY: B. COOPER 10/8/2007 SHEET 2 OF 3

TABLE 4						MATED HEIGHT WITH QSE-DP-01
STYLE	"D"	GROUND PLANE	TERMINAL	FILLER BODY	SPACER BODY	
-04	.600[15.24]	T-1G1-04-X	T-1S41-04-X	QTE-20-03-D-XX	QTEH-20-01-D-XX-X	.630 [16.00] REF
-05	.718[18.237]	T-1G1-05-X	T-1S41-05-X	QTE-20-03-D-XX	QTEH-20-01-D-XX-X	.748 [19.00] REF
-06	.835[21.209]	T-1G1-06-X	T-1S41-06-X	QTE-20-03-D-XX	QTEH-20-02-D-XX-X	.866 [22.00] REF
-07	.954[24.232]	T-1G17-01-X	T-1S61-01-X	QTEH-20-04-D-XX-X	QTE-20-02-D-XX-X	.984 [25.00] REF
-08	1.151[29.24]	T-1G17-02-X	T-1S54-02-X	QTEH-20-04-D-XX-X	QTE-20-02-D-XX-X	1.181 [30.00] REF
-09	.522[13.259]	T-1G1-09-X	T-1S60-09-x	QTEH-20-01-D-XX-X	QTE-20-02-D-XX-X	.551[14.00] REF
-10	.5606[14.239]	T-1G1-10-X	T-1S60-10-x	QTEH-20-01-D-XX-X	QTE-20-02-D-XX-X	.591[15.00] REF

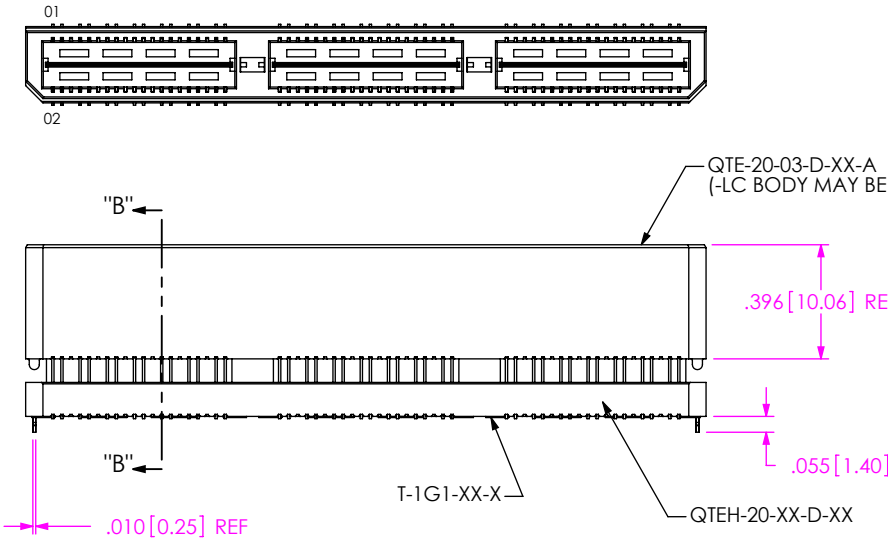

**FIG. 2**  
CQTE-042-04-X-D-DP-LC SHOWN  
(SAME AS FIG. 1, UNLESS OTHERWISE STATED)  
(STYLES -04, -05, & -06)

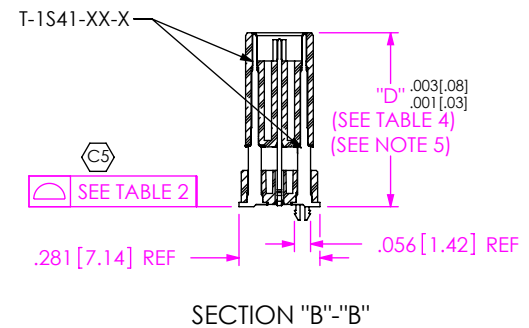

-LC: LOCKING CLIP OPTION SHOWN

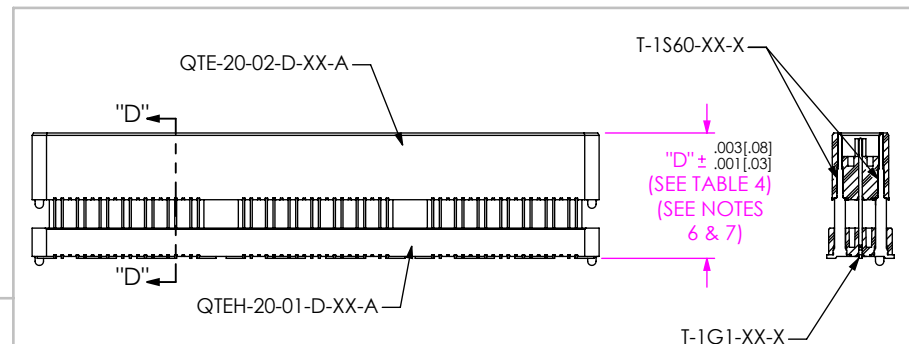
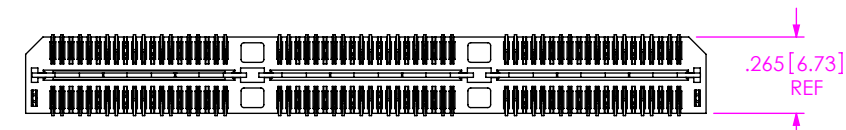

**FIG. 4**  
CQTE-042-09-X-D-DP-A SHOWN  
(DIFFERENT AS SHOWN, OTHERWISE SAME AS FIG. 2)  
(STYLES -09 & -10)

SECTION "D"-"D"  
SCALE 1.25 : 1

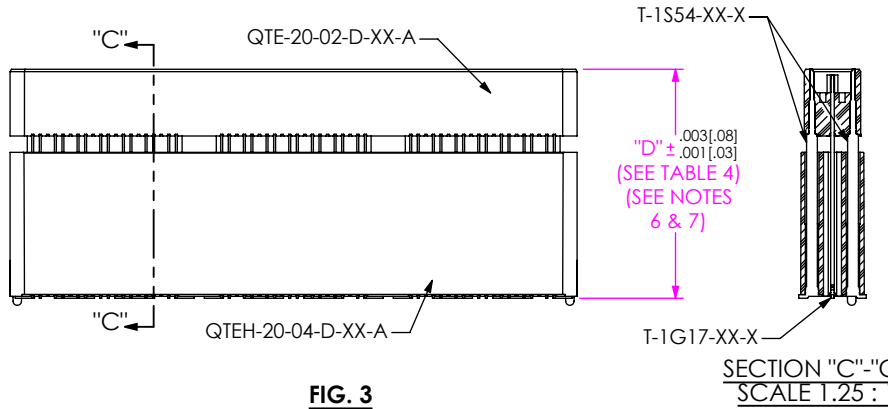

**FIG. 3**  
CQTE-042-07-X-D-DP-A SHOWN  
(DIFFERENT AS SHOWN, OTHERWISE SAME AS FIG. 2)  
(STYLES -07 & -08)

SECTION "C"-"C"  
SCALE 1.25 : 1

F:\DWG\MISC\MKTG\CQTE-XXX-XX-X-D-DP-XX-MKT.SLDDRW

**PROPRIETARY NOTE**  
THIS DOCUMENT CONTAINS INFORMATION CONFIDENTIAL AND PROPRIETARY TO SAMTEC, INC. AND SHALL NOT BE REPRODUCED OR TRANSFERRED TO OTHER DOCUMENTS OR DISCLOSED TO OTHERS OR USED FOR ANY PURPOSE OTHER THAN THAT WHICH IT WAS OBTAINED WITHOUT THE EXPRESSED WRITTEN CONSENT OF SAMTEC, INC.



520 PARK EAST BLVD. NEW ALBANY, IN 47150  
PHONE: 812-944-6733 FAX: 812-948-5047  
e-Mail: info@SAMTEC.com code: 55322

DO NOT SCALE DRAWING

SHEET SCALE: 1.5:1

DESCRIPTION:  
.8mm DIFFERENTIAL PAIRS HS TERMINAL ASSEMBLY

DWG. NO.  
**CQTE-XXX-XX-X-D-DP-XX**

BY: B. COOPER 10/8/2007 SHEET 3 OF 3