

DELPHI SERIES



Delphi Series Q36SR, Quarter Brick 228W DC/DC Power Modules: 18V~75Vin, 12V, 19Aout

The Delphi Series Q36SR, Quarter Brick, 18V~75Vin input, single output, isolated DC/DC converters, are the latest offering from a world leader in power systems technology and manufacturing — Delta Electronics, Inc. With creative design technology and optimization of component placement, these converters possess outstanding electrical and thermal performance, as well as extremely high reliability under highly stressful operating conditions. Typical efficiency of the 12V/19A module is greater than 93%.

FEATURES

- ◆ High efficiency: 93% @ 12V/19A
- ◆ Size:
 - 58.4x36.8x11.7mm (2.30"x1.45"x0.46") w/o heat-spreader
 - 58.4x36.8x12.7mm (2.30"x1.45"x0.50") with heat-spreader
- ◆ Industry standard footprint and pinout
- ◆ Fixed frequency operation
- ◆ Input UVLO
- ◆ OTP and OVP
- ◆ Output OCP hiccup mode
- ◆ Output voltage trim down : -10%
- ◆ Output voltage trim up: +10% at Vin>20V
- ◆ Monotonic startup into normal and pre-biased loads
- ◆ 1500V isolation and basic insulation
- ◆ No minimum load required
- ◆ No negative current during power or enable on/off
- ◆ ISO 9001, TL 9000, ISO 14001, QS 9000, OHSAS18001 certified manufacturing facility
- ◆ UL/cUL 60950-1 (US & Canada)

OPTIONS

- ◆ Positive or negative remote On/Off

APPLICATIONS

- ◆ Optical Transport
- ◆ Data Networking
- ◆ Communications
- ◆ Servers

TECHNICAL SPECIFICATIONS

($T_A=25^{\circ}\text{C}$, airflow rate=300 LFM, $V_{in}=48\text{Vdc}$, nominal V_{out} unless otherwise noted.)

| PARAMETER | NOTES and CONDITIONS | Q36SR12019 | | | |
|--|--|------------|-----------|----------|----------------------|
| | | Min. | Typ. | Max. | Units |
| ABSOLUTE MAXIMUM RATINGS | | | | | |
| Input Voltage | | | | | Vdc |
| Continuous | | 0 | | 80 | Vdc |
| Transient (100ms) | 100ms | | | 100 | Vdc |
| Operating Temperature | | -40 | | 85 | $^{\circ}\text{C}$ |
| Storage Temperature | | -55 | | 125 | $^{\circ}\text{C}$ |
| Input/Output Isolation Voltage | | | | 1500 | Vdc |
| INPUT CHARACTERISTICS | | | | | |
| Operating Input Voltage | | 18 | 48 | 75 | Vdc |
| Input Under-Voltage Lockout | | | | | |
| Turn-On Voltage Threshold | | 16 | 17 | 18 | Vdc |
| Turn-Off Voltage Threshold | | 15 | 16 | 17 | Vdc |
| Lockout Hysteresis Voltage | | 0.3 | 1 | 1.8 | Vdc |
| Maximum Input Current | 100% Load, 18Vin | | | 17 | A |
| No-Load Input Current | $V_{in}=48\text{V}, I_o=0\text{A}$ | | 100 | | mA |
| Off Converter Input Current | $V_{in}=48\text{V}$ | | 10 | | mA |
| Inrush Current (I^2t) | | | | 1 | A^2s |
| Input Reflected-Ripple Current | P-P thru 12 μH inductor, 5Hz to 20MHz | | 20 | | mA |
| Input Voltage Ripple Rejection | 120 Hz | | 50 | | dB |
| OUTPUT CHARACTERISTICS | | | | | |
| Output Voltage Set Point | $V_{in}=48\text{V}, I_o=I_{o,max}, T_c=25^{\circ}\text{C}$ | 11.82 | 12.00 | 12.18 | Vdc |
| Output Voltage Regulation | | | | | |
| Over Load | $I_o=I_o, \text{min to } I_o, \text{max}$ | | ± 3 | ± 15 | mV |
| Over Line | $V_{in}=18\text{V to } 75\text{V}$ | | ± 3 | ± 15 | mV |
| Over Temperature | $T_c=-40^{\circ}\text{C to } 110^{\circ}\text{C}$ | | ± 120 | | mV |
| Total Output Voltage Range | Over sample load, line and temperature | 11.64 | 12.00 | 12.36 | V |
| Output Voltage Ripple and Noise | 5Hz to 20MHz bandwidth | | | | |
| Peak-to-Peak | Full Load, 1 μF ceramic, 10 μF tantalum | | 100 | | mV |
| RMS | Full Load, 1 μF ceramic, 10 μF tantalum | | | | mV |
| Operating Output Current Range | $V_{in}=18\text{V to } 75\text{V}$ | 0 | | 19 | A |
| Operating Output Current Range | | | | | |
| Output Over Current Protection(hiccup model) | Output Voltage 10% Low | 110 | | 140 | % |
| DYNAMIC CHARACTERISTICS | | | | | |
| Output Voltage Current Transient | $V_{in}=48\text{V}, 10\mu\text{F Tan \& } 1\mu\text{F Ceramic cap}, 0.1\text{A}/\mu\text{s}$ | | | | |
| Positive Step Change in Output Current | 75% $I_{o,max}$ to 50% $I_{o,max}$ | | 550 | | mV |
| Negative Step Change in Output Current | 50% $I_{o,max}$ to 75% $I_{o,max}$ | | 550 | | mV |
| Settling Time (within 1% V_{out} nominal) | | | 200 | | μs |
| Turn-On Transient | | | | | |
| Start-Up Time, From On/Off Control | | | 28 | | mS |
| Start-Up Time, From Input | | | 28 | | mS |
| Output Capacitance (note1) | Full load; 5% overshoot of V_{out} at startup | 0 | | 5000 | μF |
| EFFICIENCY | | | | | |
| 100% Load | $V_{in}=24\text{V}$ | | 93.5 | | % |
| 100% Load | $V_{in}=48\text{V}$ | | 93.0 | | % |
| 60% Load | $V_{in}=48\text{V}$ | | 92.0 | | % |
| ISOLATION CHARACTERISTICS | | | | | |
| Input to Output | | | | 1500 | Vdc |
| Isolation Resistance | | 10 | | | M Ω |
| Isolation Capacitance | | | 1000 | | pF |
| FEATURE CHARACTERISTICS | | | | | |
| Switching Frequency | | | 260 | | KHz |
| ON/OFF Control, Negative Remote On/Off logic | | | | | |
| Logic Low (Module On) | $V_{on/off}$ | | | 0.8 | V |
| Logic High (Module Off) | $V_{on/off}$ | 2.4 | | 5 | V |
| ON/OFF Control, Positive Remote On/Off logic | | | | | |
| Logic Low (Module Off) | $V_{on/off}$ | | | 0.8 | V |
| Logic High (Module On) | $V_{on/off}$ | 2.4 | | 5 | V |
| ON/OFF Current (for both remote on/off logic) | $I_{on/off}$ at $V_{on/off}=0\text{V}$ | | | 1 | mA |
| Leakage Current (for both remote on/off logic) | Logic High, $V_{on/off}=5\text{V}$ | | | | |
| Output Voltage Trim Range(note 2) | P_{out} max rated power, I_o $I_{o,max}$ | -10 | | 10 | % |
| Output Voltage Remote Sense Range | P_{out} max rated power, I_o $I_{o,max}$ | | | 10 | % |
| Output Over-Voltage Protection | Over full temp range; % of nominal V_{out} | 115 | | 140 | % |
| GENERAL SPECIFICATIONS | | | | | |
| MTBF | $I_o=80\%$ of $I_o, \text{max}; T_a=25^{\circ}\text{C}, \text{normal input}, 600\text{FLM}$ | | | | M hours |
| Weight | Without heat spreader | | 45.5 | | grams |
| Weight | With heat spreader | | 61.1 | | grams |
| Over-Temperature Shutdown (Without heat spreader) | Refer to Figure 19 for Hot spot location | | 135 | | $^{\circ}\text{C}$ |
| Over-Temperature Shutdown (NTC resistor) | Refer to Figure 19 for NTC resistor location | | 130 | | $^{\circ}\text{C}$ |

Note: Please attach thermocouple on NTC resistor to test OTP function, the hot spots' temperature is just for reference.

Note1: For applications with higher output capacitive load, please contact Delta

Note2: Trim down range -10% for 18Vin ~75Vin, Trim up range +10% for 20Vin ~ 75Vin.



ELECTRICAL CHARACTERISTICS CURVES

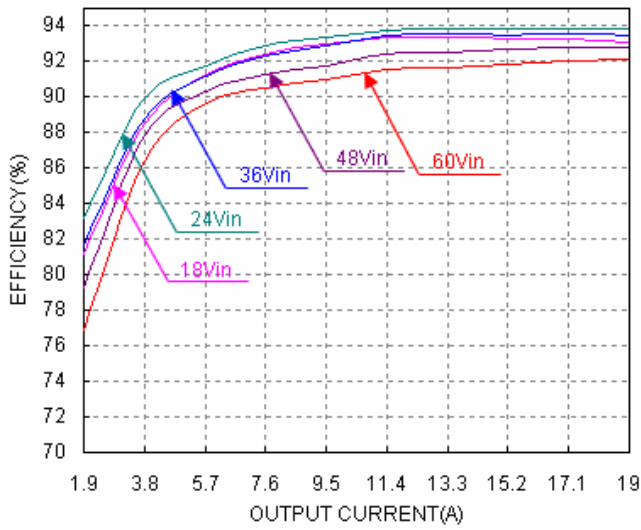

Figure 1: Efficiency vs. load current for minimum, nominal, and maximum input voltage at 25°C

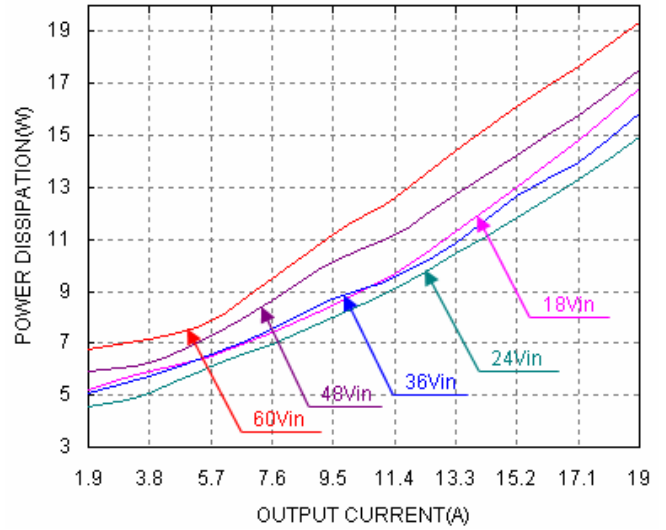

Figure 2: Power dissipation vs. load current for minimum, nominal, and maximum input voltage at 25°C.

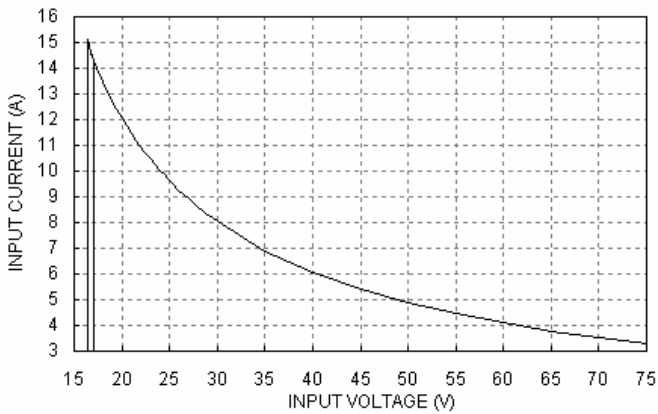

Figure 3: Typical full load input characteristics at room temperature

ELECTRICAL CHARACTERISTICS CURVES

For Negative Remote On/Off Logic

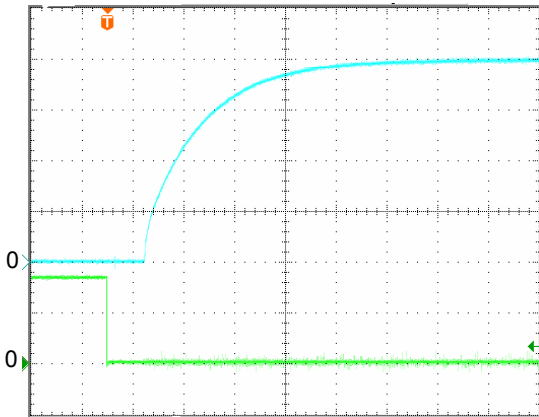

Figure 4: Turn-on transient at full rated load current (resistive load) (10 ms/div). $V_{in}=48V$. Top Trace: V_{out} , 3.0V/div; Bottom Trace: ON/OFF input, 3V/div

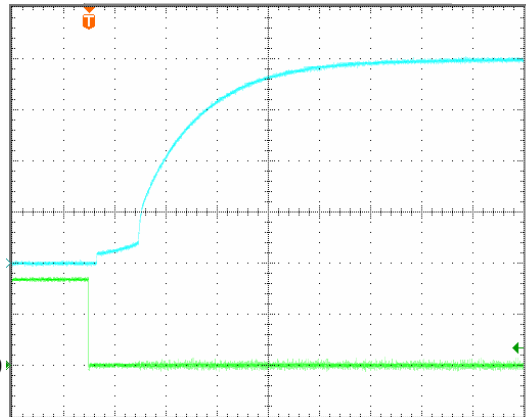

Figure 5: Turn-on transient at zero load current (10 ms/div). $V_{in}=48V$. Top Trace: V_{out} : 3.0V/div, Bottom Trace: ON/OFF input, 3V/div

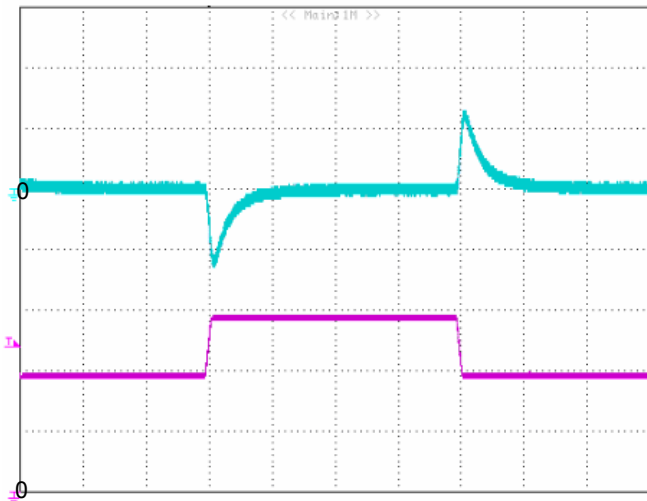

Figure 6: Output voltage response to step-change in load current (50%-75%-50% of I_o , max; $di/dt = 0.1A/\mu s$; V_{in} is 24V). Load cap: 10 μF tantalum capacitor and 1 μF ceramic capacitor. Top Trace: V_{out} (0.5V/div, 500 μs /div), Bottom Trace: I_{out} (5A/div). Scope measurement should be made using a BNC cable (length shorter than 20 inches). Position the load between 51 mm to 76 mm (2 inches to 3 inches) from the module

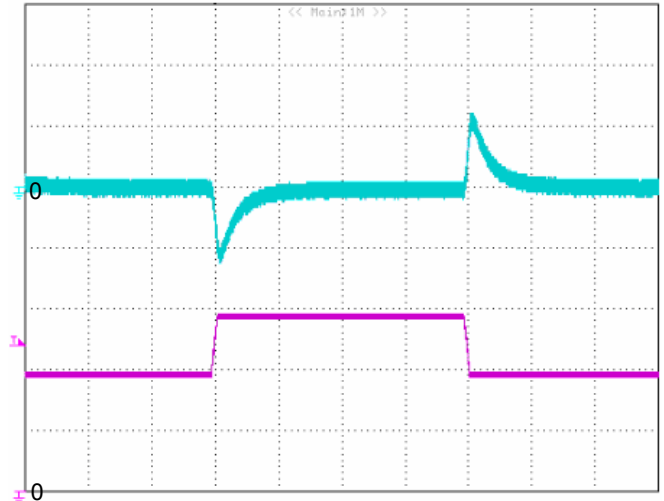

Figure 7: Output voltage response to step-change in load current (50%-75%-50% of I_o , max; $di/dt = 0.1A/\mu s$; V_{in} is 48V). Load cap: 10 μF tantalum capacitor and 1 μF ceramic capacitor. Top Trace: V_{out} (0.5V/div, 500 μs /div), Bottom Trace: I_{out} (5A/div). Scope measurement should be made using a BNC cable (length shorter than 20 inches). Position the load between 51 mm to 76 mm (2 inches to 3 inches) from the module

ELECTRICAL CHARACTERISTICS CURVES

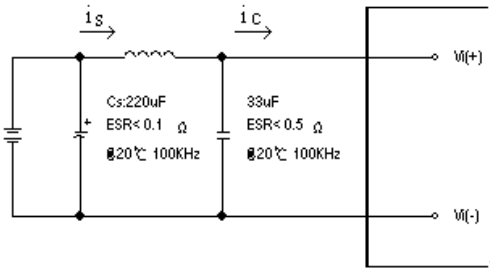

Figure 8: Test set-up diagram showing measurement points for Input Terminal Ripple Current and Input Reflected Ripple Current.

Note: Measured input reflected-ripple current with a simulated source Inductance (L_{TEST}) of $12\mu H$. Capacitor C_s offset possible battery impedance. Measure current as shown above

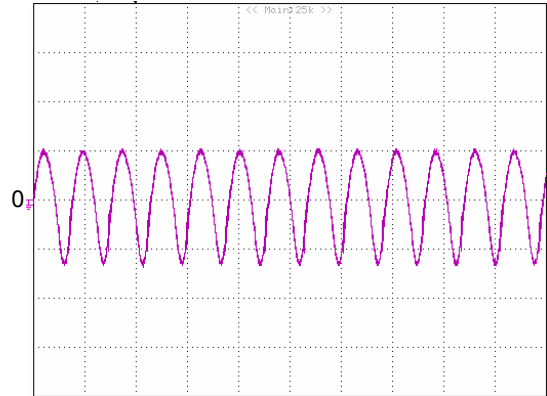

Figure 9: Input Terminal Ripple Current, i_c , at full rated output current and nominal input voltage ($V_{in}=48V$) with $12\mu H$ source impedance and $33\mu F$ electrolytic capacitor ($1A/div$, $5\mu s/div$)

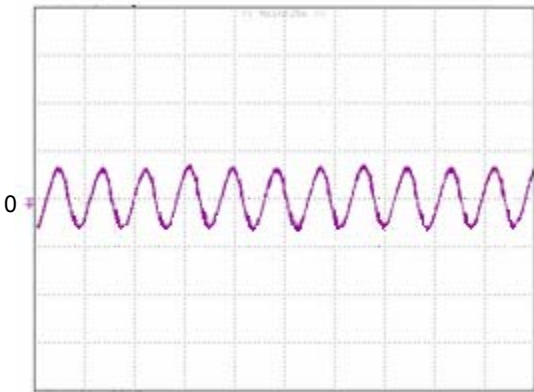

Figure 10: Input reflected ripple current, i_s , through a $12\mu H$ source inductor at nominal input voltage ($V_{in}=48V$) and rated load current (20 mA/div , $5\mu s/div$)

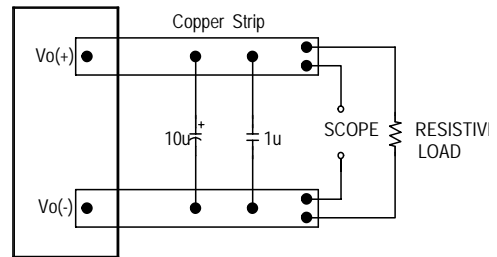

Figure 11: Output voltage noise and ripple measurement test setup

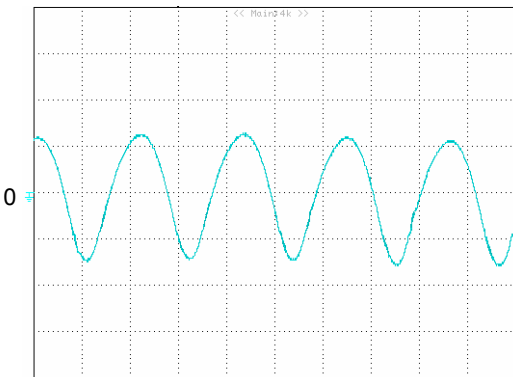

Figure 12: Output voltage ripple at nominal input voltage ($V_{in}=48V$) and rated load current (50 mV/div , $2\mu s/div$). Load capacitance: $1\mu F$ ceramic capacitor and $10\mu F$ tantalum capacitor. Bandwidth: 20 MHz . Scope measurements should be made using a BNC cable (length shorter than 20 inches). Position the load between 51 mm to 76 mm (2 inches to 3 inches) from the module

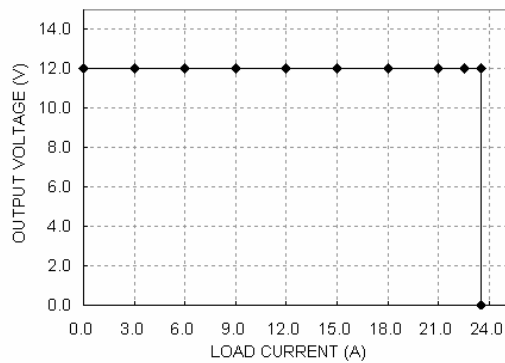

Figure 13: Output voltage vs. load current showing typical current limit curves and converter shutdown points ($V_{in}=48V$)

DESIGN CONSIDERATIONS

Input Source Impedance

The impedance of the input source connecting to the DC/DC power modules will interact with the modules and affect the stability. A low ac-impedance input source is recommended. If the source inductance is more than a few μH , we advise adding a 100 μF electrolytic capacitor (ESR < 0.7 Ω at 100 kHz) mounted close to the input of the module to improve the stability.

Layout and EMC Considerations

Delta's DC/DC power modules are designed to operate in a wide variety of systems and applications. For design assistance with EMC compliance and related PWB layout issues, please contact Delta's technical support team. An external input filter module is available for easier EMC compliance design. Below is the reference design for an input filter tested with Q36SR12019 to meet class A in CISPR 22.

Schematic and Components List



CX1=4*2.2 μF /100V ceramic cap

CX2=100 μF /100V electrolytic cap

Delta standard EMI filter, FL75L20

Test result:

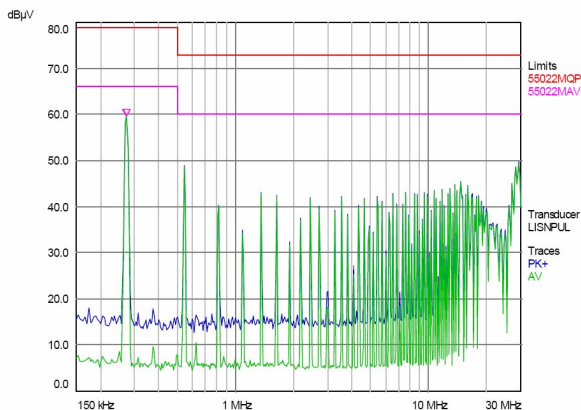

25C, 48Vin, Green line is quasi peak mode and blue line is average mode.

Safety Considerations

The power module must be installed in compliance with the spacing and separation requirements of the

end-user's safety agency standard, i.e., UL60950-1, CSA C22.2 NO. 60950-1 2nd and IEC 60950-1 2nd : 2005 and EN 60950-1 2nd: 2006+A11+A1: 2010, if the system in which the power module is to be used must meet safety agency requirements.

Basic insulation based on 75 Vdc input is provided between the input and output of the module for the purpose of applying insulation requirements when the input to this DC-to-DC converter is identified as TNV-2 or SELV. An additional evaluation is needed if the source is other than TNV-2 or SELV.

When the input source is SELV circuit, the power module meets SELV (safety extra-low voltage) requirements. If the input source is a hazardous voltage which is greater than 60 Vdc and less than or equal to 75 Vdc, for the module's output to meet SELV requirements, all of the following must be met:

- The input source must be insulated from the ac mains by reinforced or double insulation.
- The input terminals of the module are not operator accessible.
- A SELV reliability test is conducted on the system where the module is used, in combination with the module, to ensure that under a single fault, hazardous voltage does not appear at the module's output.

When installed into a Class II equipment (without grounding), spacing consideration should be given to the end-use installation, as the spacing between the module and mounting surface have not been evaluated.

The power module has extra-low voltage (ELV) outputs when all inputs are ELV.

This power module is not internally fused. To achieve optimum safety and system protection, an input line fuse is highly recommended. The safety agencies require a Fast-acting fuse with 50A maximum rating to be installed in the ungrounded lead. A lower rated fuse can be used based on the maximum inrush transient energy and maximum input current.

Soldering and Cleaning Considerations

Post solder cleaning is usually the final board assembly process before the board or system undergoes electrical testing. Inadequate cleaning and/or drying may lower the reliability of a power module and severely affect the finished circuit board assembly test. Adequate cleaning and/or drying is especially important for un-encapsulated and/or open frame type power modules. For assistance on appropriate soldering and cleaning procedures, please contact Delta's technical support team.

FEATURES DESCRIPTIONS

Over-Current Protection

The modules include an internal output over-current protection circuit, which will endure current limiting for an unlimited duration during output overload. If the output current exceeds the OCP set point, the modules will automatically shut down, and enter hiccup mode.

For hiccup mode, the module will try to restart after shutdown. If the over current condition still exists, the module will shut down again. This restart trial will continue until the over-current condition is corrected.

Over-Voltage Protection

The modules include an internal output over-voltage protection circuit, which monitors the voltage on the output terminals. If this voltage exceeds the over-voltage set point, the module will shut down, and enter in hiccup

For hiccup mode, the module will try to restart after shutdown. If the over voltage condition still exists, the module will shut down again. This restart trial will continue until the over-voltage condition is corrected.

Over-Temperature Protection

The over-temperature protection consists of circuitry that provides protection from thermal damage. If the temperature exceeds the over-temperature threshold the module will shut down, and enter in hiccup.

For hiccup mode, the module will try to restart after shutdown. This restart trial will continue until the over-temperature condition is corrected.

Remote On/Off

The remote on/off feature on the module can be either negative or positive logic. Negative logic turns the module on during a logic low and off during a logic high. Positive logic turns the modules on during a logic high and off during a logic low.

Remote on/off can be controlled by an external switch between the on/off terminal and the Vi(-) terminal. The switch can be an open collector or open drain.

For negative logic if the remote on/off feature is not used, please short the on/off pin to Vi(-). For positive logic if the remote on/off feature is not used, please leave the on/off pin floating.

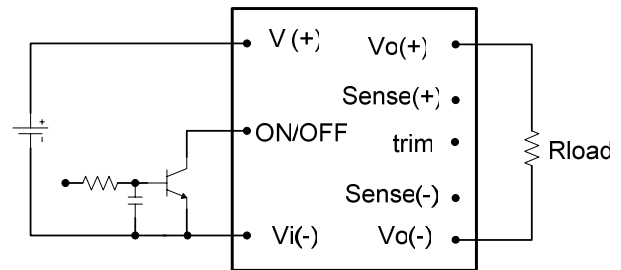

Figure 14: Remote on/off implementation

Remote Sense

Remote sense compensates for voltage drops on the output by sensing the actual output voltage at the point of load. The voltage between the remote sense pins and the output terminals must not exceed the output voltage sense range given here:

$$[Vo(+) - Vo(-)] - [SENSE(+) - SENSE(-)] \leq 10\% \times V_{out}$$

This limit includes any increase in voltage due to remote sense compensation and output voltage set point adjustment (trim).

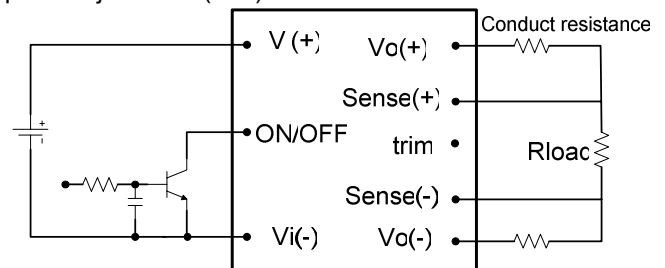

Figure 15: Effective circuit configuration for remote sense operation

FEATURES DESCRIPTIONS (CON.)

If the remote sense feature is not used to regulate the output at the point of load, please connect SENSE(+) to Vo(+) and SENSE(-) to Vo(-) at the module.

The output voltage can be increased by both the remote sense and the trim; however, the maximum increase is the larger of either the remote sense or the trim, not the sum of both.

When using remote sense and trim, the output voltage of the module is usually increased, which increases the power output of the module with the same output current.

Care should be taken to ensure that the maximum output power does not exceed the maximum rated power.

Output Voltage Adjustment (TRIM)

To increase or decrease the output voltage set point, connect an external resistor between the TRIM pin and the SENSE(+) or SENSE(-). The TRIM pin should be left open if this feature is not used.

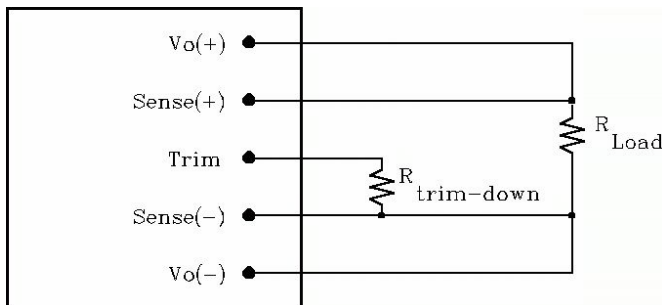

Figure 16: Circuit configuration for trim-down (decrease output voltage)

If the external resistor is connected between the TRIM and SENSE (-) pins, the output voltage set point decreases (Fig. 16). The external resistor value required to obtain a percentage of output voltage change % is defined as:

$$R_{trim-down} = \left[\frac{511}{\Delta} - 10.2 \right] (K\Omega)$$

Ex. When Trim-down -10% (12V×0.9=10.8V)

$$R_{trim-down} = \left[\frac{511}{10} - 10.2 \right] (K\Omega) = 40.9(K\Omega)$$

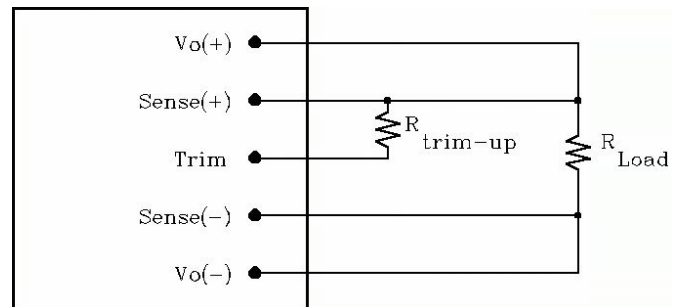

Figure 17: Circuit configuration for trim-up (increase output voltage)

If the external resistor is connected between the TRIM and SENSE (+) the output voltage set point increases (Fig. 17). The external resistor value required to obtain a percentage output voltage change % is defined as:

$$R_{trim-up} = \frac{5.11 V_o (100 + \Delta)}{1.225 \Delta} - \frac{511}{\Delta} - 10.2 (K\Omega)$$

Ex. When Trim-up +10% (12V×1.1=13.2V)

$$R_{trim-up} = \frac{5.11 \times 12 \times (100 + 10)}{1.225 \times 10} - \frac{511}{10} - 10.2 = 489.3 (K\Omega)$$

The output voltage can be increased by both the remote sense and the trim, however the maximum increase is the larger of either the remote sense or the trim, not the sum of both.

When using remote sense and trim, the output voltage of the module is usually increased, which increases the power output of the module with the same output current.

Care should be taken to ensure that the maximum output power of the module remains at or below the maximum rated power.

THERMAL CONSIDERATIONS

Thermal management is an important part of the system design. To ensure proper, reliable operation, sufficient cooling of the power module is needed over the entire temperature range of the module. Convection cooling is usually the dominant mode of heat transfer.

Hence, the choice of equipment to characterize the thermal performance of the power module is a wind tunnel.

Thermal Testing Setup

Delta's DC/DC power modules are characterized in heated vertical wind tunnels that simulate the thermal environments encountered in most electronics equipment. This type of equipment commonly uses vertically mounted circuit cards in cabinet racks in which the power modules are mounted.

The following figure shows the wind tunnel characterization setup. The power module is mounted on a test PWB and is vertically positioned within the wind tunnel. The space between the neighboring PWB and the top of the power module is constantly kept at 6.35mm (0.25").

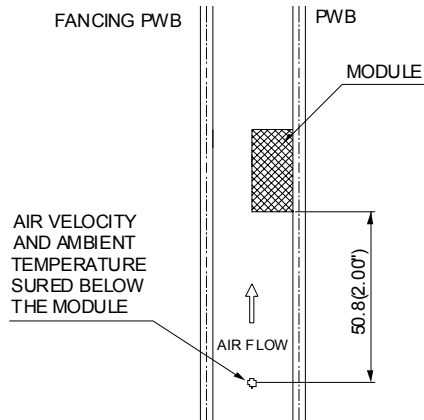

Note: Wind Tunnel Test Setup Figure Dimensions are in millimeters and (Inches)

Figure 18: Wind tunnel test setup

Thermal Derating

Heat can be removed by increasing airflow over the module. To enhance system reliability, the power module should always be operated below the maximum operating temperature. If the temperature exceeds the maximum module temperature, reliability of the unit may be affected.

THERMAL CURVES (LONGITUDINAL ORIENTATION)

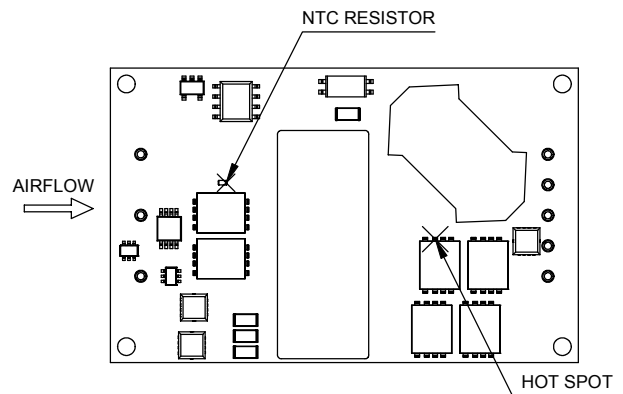

Figure 19: * Hot spot & NTC resistor temperature measured points

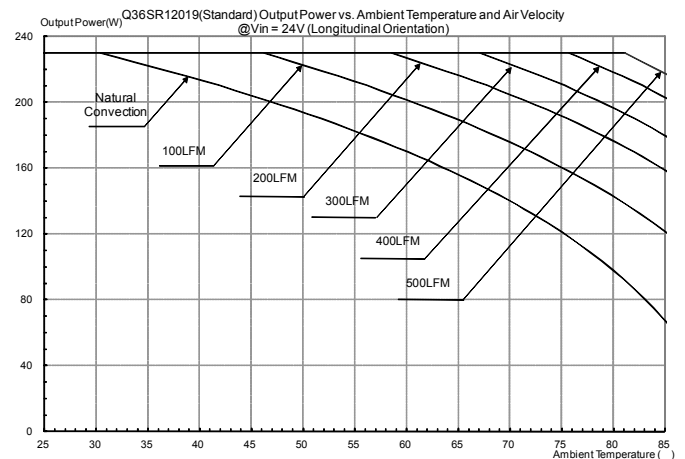

Figure 20: Output power vs. Ambient temperature @Vin=24V (Longitudinal orientation, Airflow direction from Vin+ to Vout+, without heat spreader)

THERMAL CURVES (LONGITUDINAL ORIENTATION)

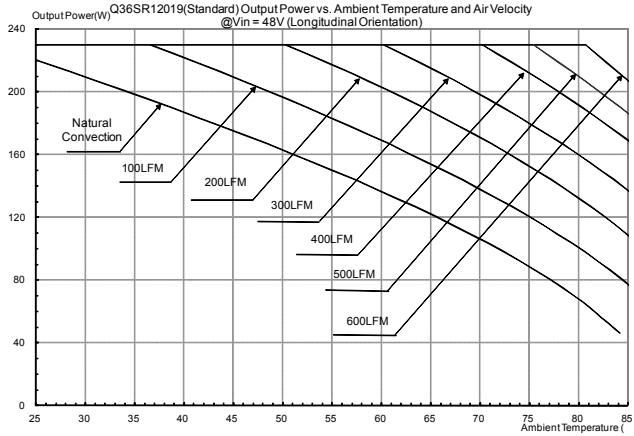

Figure 21: Output power vs. Ambient temperature @Vin=48V (Longitudinal orientation, Airflow direction from Vin+ to Vout+, without heat spreader)

THERMAL CURVES (TRANSVERSE ORIENTATION)

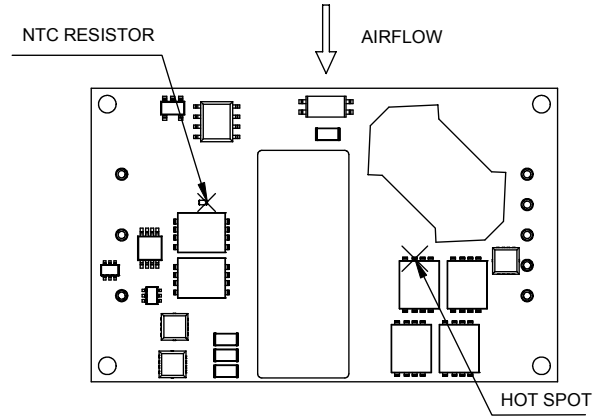

Figure 23: * Hot spot & NTC resistor temperature measured points

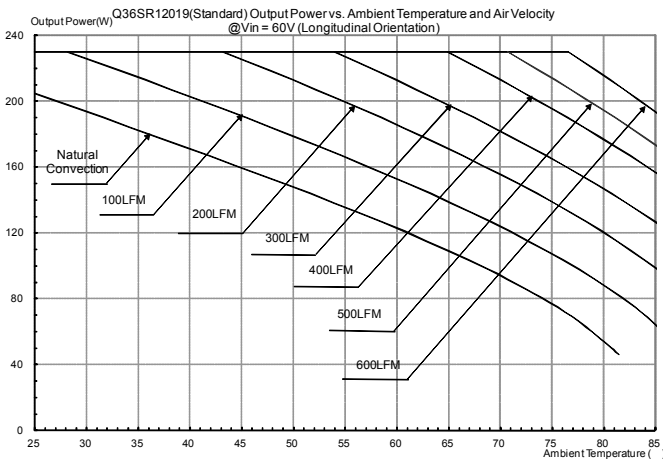

Figure 22: Output power vs. Ambient temperature @Vin=60V (Longitudinal orientation, Airflow direction from Vin+ to Vout+, without heat spreader)

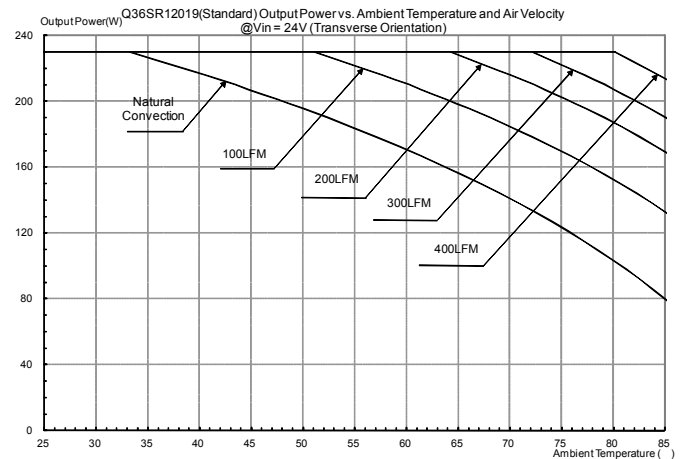

Figure 24: Output power vs. Ambient temperature @Vin=24V (Transverse orientation, Airflow direction from Vin+ to Vin-, without heat spreader)

THERMAL CURVES (TRANSVERSE ORIENTATION)

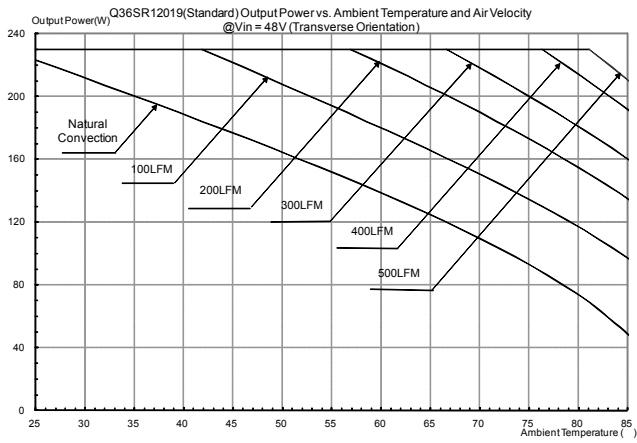

Figure 25: Output power vs. Ambient temperature @Vin=48V (Transverse orientation, Airflow direction from Vin+ to Vin-, without heat spreader)

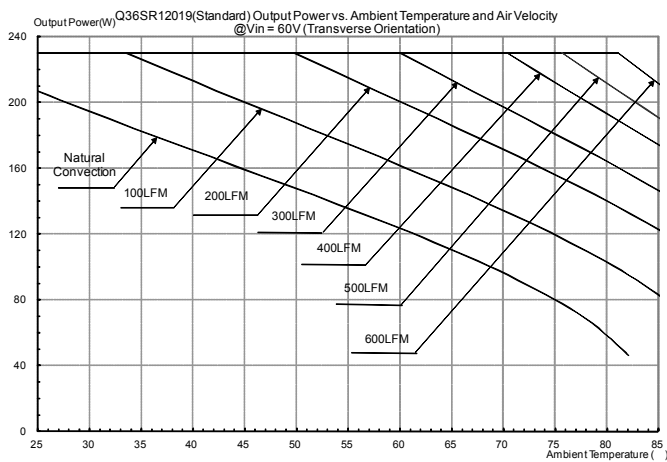
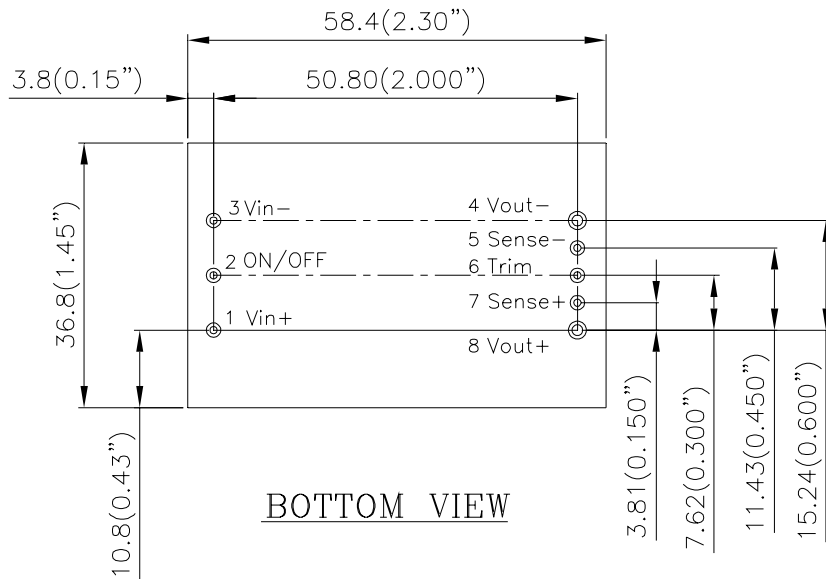
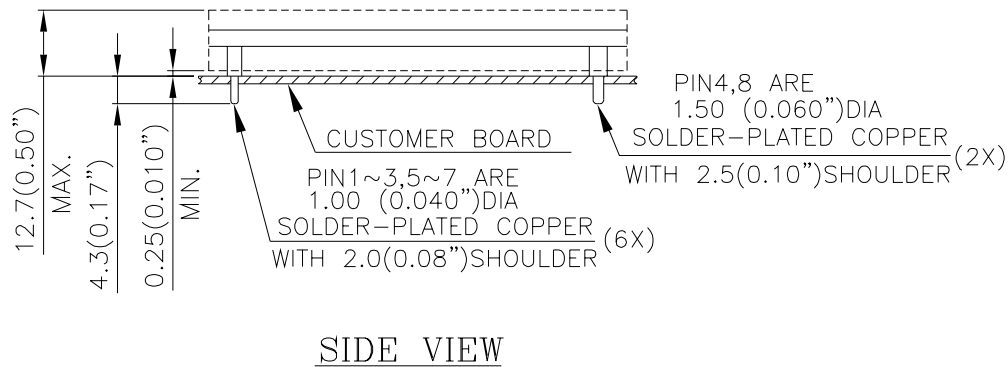
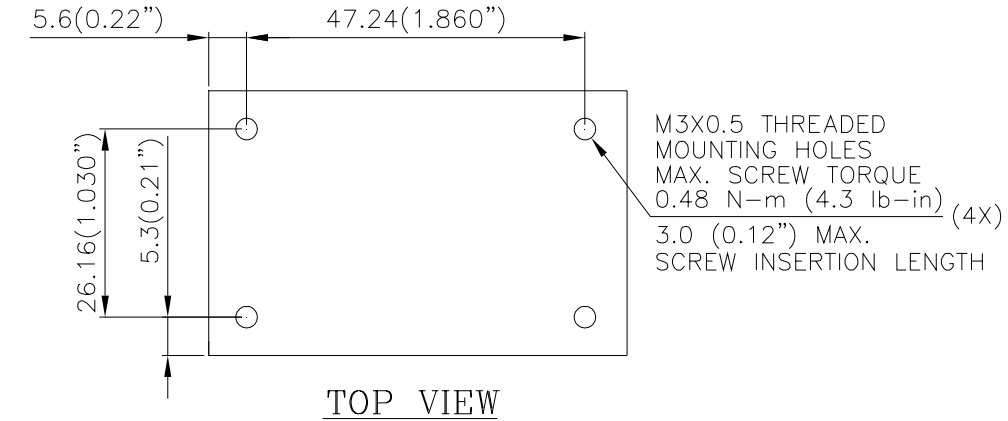

Figure 26: Output power vs. Ambient temperature @Vin=60V (Transverse orientation, Airflow direction from Vin+ to Vin-, without heat spreader)

MECHANICAL DRAWING (WITH HEAT-SPREADER)

For modules with through-hole pins and the optional heatspreader, they are intended for wave soldering assembly onto system boards; please do not subject such modules through reflow temperature profile.



NOTES:
DIMENSIONS ARE IN MILLIMETERS AND (INCHES)
TOLERANCES: X.Xmm±0.5mm(X.XX in.±0.02 in.)
X.XXmm±0.25mm(X.XXX in.±0.010 in.)

MECHANICAL DRAWING (WITHOUT HEAT-SPREADER)

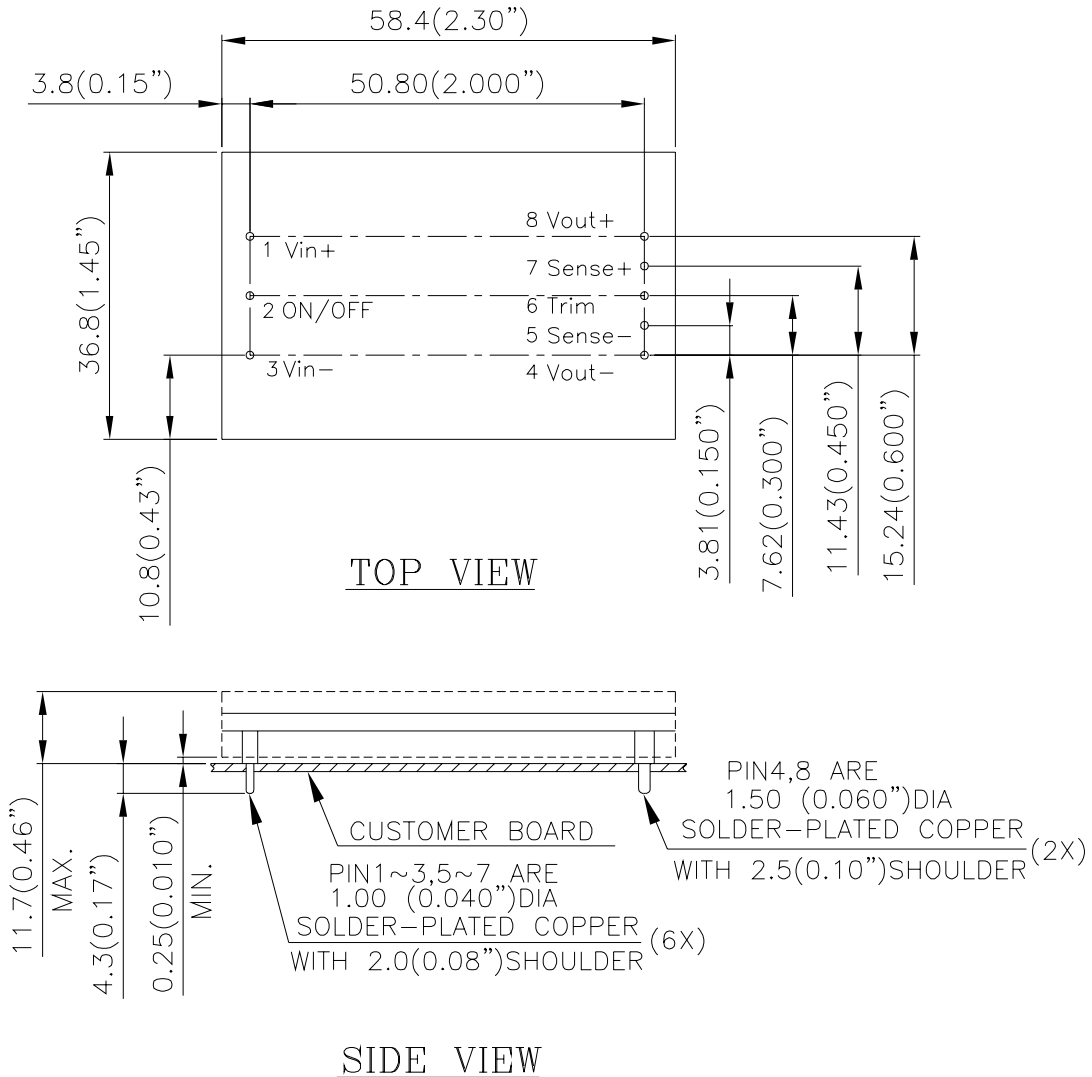

NOTES:
 DIMENSIONS ARE IN MILLIMETERS AND (INCHES)
 TOLERANCES: X.Xmm±0.5mm(X.XX in.±0.02 in.)
 X.XXmm±0.25mm(X.XXX in.±0.010 in.)

| Pin No. | Name | Function |
|----------------|-------------|-------------------------|
| 1 | +Vin | Positive input voltage |
| 2 | ON/OFF | Remote ON/OFF |
| 3 | -Vin | Negative input voltage |
| 4 | -Vout | Negative output voltage |
| 5 | -Sense | Negative remote sense |
| 6 | Trim | Output voltage trim |
| 7 | +Sense | Positive remote sense |
| 8 | +Vout | Positive output voltage |

Pin Specification:

Pins 1-3,5-7 1.00mm (0.040") diameter
 Pins 4 & 8 1.50mm (0.060") diameter

All pins are copper alloy with matte Tin plated over Nickel underplating.

PART NUMBERING SYSTEM

| Q | 36 | S | R | 120 | 19 | N | R | F | A |
|-----------------|---------------|-------------------|----------------|----------------|----------------|----------------------------|--|--|--|
| Type of Product | Input Voltage | Number of Outputs | Product Series | Output Voltage | Output Current | ON/OFF Logic | Pin Length/Type | | Option Code |
| Q - 1/4 Brick | 36 - 18V~75V | S - Single | R - Regular | 120 - 12V | 19 - 19A | N- Negative P- Positive | R - 0.170" N - 0.146" K - 0.110" | Space - RoHS 5/6 F - RoHS 6/6 (Lead Free) | A - Standard Functions H-with heat spreader |

MODEL LIST

| MODEL NAME | INPUT | | OUTPUT | | EFF @ 100% LOAD |
|----------------|---------|-----|--------|-----|-----------------|
| Q36SR12019NRFA | 18V~75V | 17A | 12V | 19A | 93.0% @ 48Vin |

Default remote on/off logic is negative and pin length is 0.170"

*** For modules with through-hole pins and the optional heatspreader, they are intended for wave soldering assembly onto system boards; please do not subject such modules through reflow temperature profile.**

CONTACT: www.delta.com.tw/dcdc

USA:

Telephone:
East Coast: 978-656-3993
West Coast: 510-668-5100
Fax: (978) 656 3964
Email: DCDC@delta-corp.com

Europe:

Phone: +41 31 998 53 11
Fax: +41 31 998 53 53
Email: DCDC@delta-es.com

Asia & the rest of world:

Telephone: +886 3 4526107
Ext 6220~6224
Fax: +886 3 4513485
Email: DCDC@delta.com.tw

WARRANTY

Delta offers a two (2) year limited warranty. Complete warranty information is listed on our web site or is available upon request from Delta.

Information furnished by Delta is believed to be accurate and reliable. However, no responsibility is assumed by Delta for its use, nor for any infringements of patents or other rights of third parties, which may result from its use. No license is granted by implication or otherwise under any patent or patent rights of Delta. Delta reserves the right to revise these specifications at any time, without notice.