

DEVICE PERFORMANCE SPECIFICATION

Revision 3.0 MTD/PS-0856

March 28, 2007

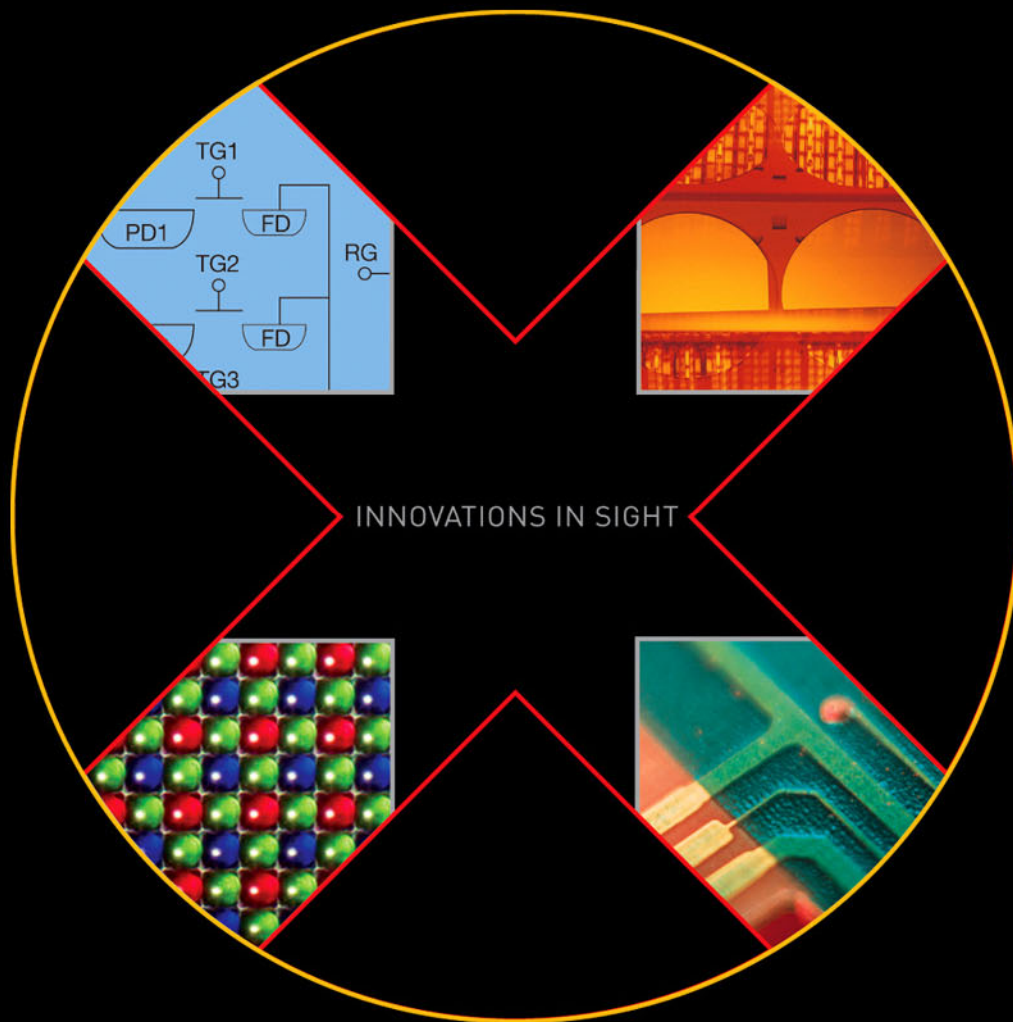

KODAK KAF-39000 IMAGE SENSOR

7216 (H) X 5412 (V) FULL-FRAME CCD IMAGE SENSOR

TABLE OF CONTENTS

Summary Specification 4
 Description 4
 Features..... 4
 Applications 4
Ordering Information 5
Device Description 6
 Architecture 6
 Dark Reference Pixels..... 7
 Dummy Pixels..... 7
 Active Buffer Pixels 7
 Image Acquisition 7
 Charge Transport 7
 Horizontal Register 8
 Output Structure 8
 Output Load 9
 Physical Description..... 10
 Pin Description and Device Orientation..... 10
Imaging Performance 12
 Typical Operational Conditions 12
 Specifications 12
Typical Performance Curves..... 14
Defect Definitions..... 17
 Operational Conditions..... 17
 Specifications 17
Operation..... 18
 Absolute Maximum Ratings⁸ 18
 Power-up Sequence 18
 DC Bias Operating Conditions 19
 AC Operating Conditions..... 19
 Clock Levels..... 19
Timing..... 20
 Requirements and Characteristics 20
 Edge Alignment 21
 Frame Timing 22
 Frame Timing Detail..... 22
 Line Timing (each output) 23
 Pixel Timing 23
 Pixel Timing Detail..... 24
Mode of Operation..... 25
 Power-up Flush Cycle..... 25
Storage and Handling 26
 Storage Conditions 26
 ESD 26
 Cover Glass Care and Cleanliness 26
 Environmental Exposure..... 26
 Soldering Recommendations 26

Mechanical Drawings	27
Completed Assembly	27
Cover Glass Specification	29
Quality Assurance And Reliability	30
Quality Strategy:	30
Replacement:	30
Liability of the Supplier:	30
Liability of the Customer:.....	30
Reliability:	30
Test Data Retention:.....	30
Mechanical:	30
Warning: Life Support Applications policy	30
Revision Changes	31

TABLE OF FIGURES

Figure 1: Sensor Architecture	6
Figure 2: Output Architecture (Left or Right).....	8
Figure 3: Recommended Output Structure Load Diagram.....	9
Figure 4: Pinout Diagram	10
Figure 5: Spectral Response (color version).....	14
Figure 6: Spectral Response (monochrome version).....	14
Figure 7: Typical GR - GB QE Difference (color version).....	15
Figure 8: Typical Normalized Angle QE (both color and monochrome versions)	15
Figure 9: Typical Anti-blooming Performance	16
Figure 10: Timing Edge Alignment.....	21
Figure 11: Frame Timing	22
Figure 12: Frame Timing Detail	22
Figure 13: Line Timing	23
Figure 14: Pixel Timing	23
Figure 15: Pixel Timing Detail	24
Figure 16: Power-up Flush Cycle.....	25
Figure 17: Modified (Slow) Flush Cycle.....	25
Figure 18: Completed Assembly Drawing (1 of 2)	27
Figure 19: Completed Assembly Drawing (2 of 2)	28

SUMMARY SPECIFICATION

KODAK KAF-39000 IMAGE SENSOR

7216 (H) X 5412 (V) FULL FRAME CCD IMAGE SENSOR

DESCRIPTION

The KODAK KAF-39000 is a dual output, high performance CCD (charge coupled device) image sensor with 7216(H) x 5412(V) photoactive pixels designed for a wide range of color and monochrome image sensing applications. Each pixel contains anti-blooming protection by means of a lateral overflow drain thereby preventing image corruption during high light level conditions. In the color version, each of the 6.8 μ m square pixels are selectively covered with red, green or blue pigmented filters for color separation. The sensor is housed in a 64 pin, 59.61 x 50.80 mm DIL ceramic package with 1.78 mm pin spacing.

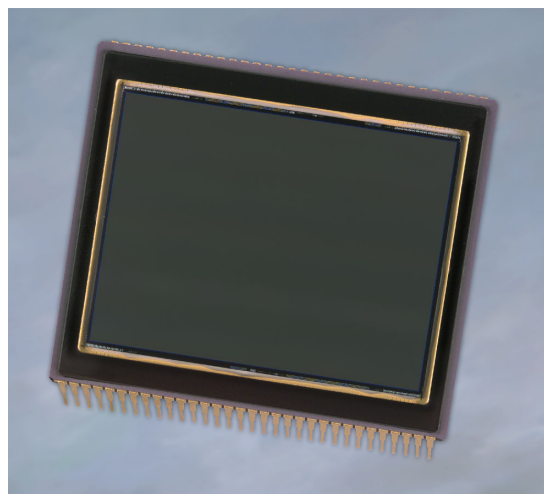

FEATURES

- Ultra-high resolution
- Broad dynamic range
- Low noise architecture
- Large active imaging area

APPLICATIONS

- Professional Digital Still Cameras and Camera Backs
- Industrial Imaging
- Aerial Photography

Parameter	Typical Value
Architecture	Full Frame CCD; with Square Pixels
Total Number of Pixels	7326 (H) x 5494 (V) = 40.2 M
Number of Effective Pixels	7256 (H) x 5452 (V) = 39.5M
Number of Active Pixels	7216 (H) x 5412 (V) = 39.0M
Pixel Size	6.8 μ m (H) x 6.8 μ m (V)
Active Image Size	49.0 mm (H) x 36.8 mm (V) 61.3 mm (diagonal)
Aspect Ratio	4:3
Horizontal Outputs	2
Saturation Signal	60 K e ⁻
Output Sensitivity	26 μ V/e ⁻
Quantum Efficiency (color version) R (610nm) G (540nm) B (470nm)	20%, 23%, 18%
Quantum Efficiency (monochrome version) (560nm)	30%
Read Noise (f=24 MHz)	16 e ⁻
Dark Signal (T=40°C)	4 mV
Dark Current Doubling Temperature	6.3° C
Linear Dynamic Range (f=24 MHz, T=40 C)	71.4 dB
Horizontal Charge Transfer Efficiency	0.999995
Vertical Charge Transfer Efficiency	0.999999
Blooming Protection (4ms exposure time)	1000X saturation exposure
Maximum Data Rate	24 MHz
Package	CERDIP (sidebrazed, CuW)
Cover Glass	AR coated, 2 sides

All parameters above are specified at T = 25° C, unless noted otherwise.

ORDERING INFORMATION

Catalog Number	Product Name	Description	Marking Code
4H0762	KAF-39000-CAA-DD-AA	Color (Bayer RGB), No Microlens, CERDIP Package (sidebrazed, CuW), Clear Cover Glass with AR coating (both sides), Standard Grade	KAF-39000-CA [Serial Number]
4H0763	KAF-39000-CAA-DD-AE	Color (Bayer RGB), No Microlens, CERDIP Package (sidebrazed, CuW), Clear Cover Glass with AR coating (both sides), Engineering Grade	
4H0946	KAF-39000-AAA-DD-AA	Monochrome, No Microlens, CERDIP Package (sidebrazed, CuW), Clear Cover Glass with AR coating (both sides), Standard Grade	KAF-39000-AA [Serial Number]
4H0947	KAF-39000-AAA-DD-AE	Monochrome, No Microlens, CERDIP Package (sidebrazed, CuW), Clear Cover Glass with AR coating (both sides), Engineering Grade	
4H0845	KEK-4H0845-KAF-39000-12-24	Evaluation Board (Complete Kit)	N/A

Please see the User's Manual (MTD/PS-0881) for information on the Evaluation Kit for this part.

Please see ISS Application Note "Product Naming Convention" (MTD/PS-0892) for a full description of naming convention used for KODAK image sensors.

Address all inquiries and purchase orders to:

Image Sensor Solutions
Eastman Kodak Company
Rochester, New York 14650-2010

Phone: (585) 722-4385
Fax: (585) 477-4947
E-mail: imagers@kodak.com

Kodak reserves the right to change any information contained herein without notice. All information furnished by Kodak is believed to be accurate.

DEVICE DESCRIPTION

ARCHITECTURE

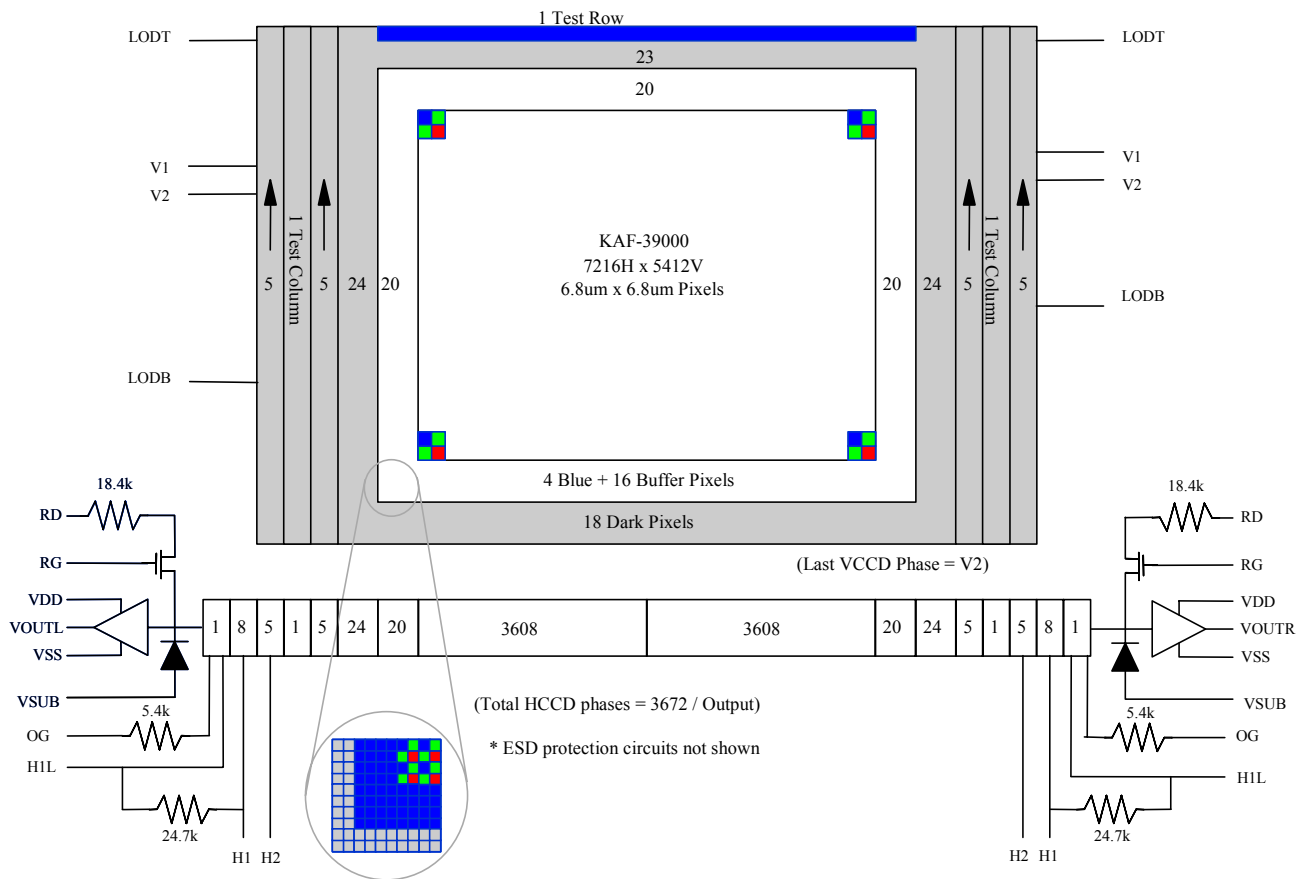

Figure 1: Sensor Architecture
(The color pattern shown is valid for the color version of this device)

Dark Reference Pixels

Surrounding the periphery of the device is a border of light shielded pixels creating a dark region. Within this dark region, exist light shielded pixels that include 24 leading dark pixels on every line. There are also 18 full dark lines at the start and 23 full dark lines at the end of every frame. Under normal circumstances, these pixels do not respond to light and may be used as a *dark reference*.

Dummy Pixels

Within each horizontal shift register there are 20 leading pixels. These are designated as *dummy pixels* and should not be used to determine a dark reference level.

Active Buffer Pixels

20 unshielded pixels adjacent to any leading or trailing dark reference regions are classified as active buffer pixels. These pixels are light sensitive but they are not tested for defects and non-uniformities. Of these 20 pixels, for the color version, the outermost 4 pixels are covered with blue pigment while the remaining are arranged in a Bayer pattern (R, GR, GB, B). The monochrome version does not have this pattern coating.

IMAGE ACQUISITION

An electronic representation of an image is formed when incident photons falling on the sensor plane create electron-hole pairs within the device. These photon-induced electrons are collected locally by the formation of potential wells at each pixel site. The number of electrons collected is linearly dependent on light level and exposure time and non-linearly dependent on wavelength. When the pixel's capacity is reached, excess electrons are discharged into the lateral overflow drain to prevent crosstalk or 'blooming'. During the integration period, the V1 and V2 register clocks are held at a constant (low) level.

CHARGE TRANSPORT

The integrated charge from each pixel is transported to the output using a two-step process. Each line (row) of charge is first transported from the vertical CCDs to a horizontal CCD register using the V1 and V2 register clocks. The horizontal CCD is presented a new line on the falling edge of V2 while H1 is held high. The horizontal CCDs then transport each line, pixel by pixel, to the output structure by alternately clocking the H1 and H2 pins in a complementary fashion. A separate connection to the last H1 phase (H1L) is provided to improve the transfer speed of charge to the output amplifier. On each falling edge of H1L a new charge packet sensed by the output amplifier.

HORIZONTAL REGISTER

Output Structure

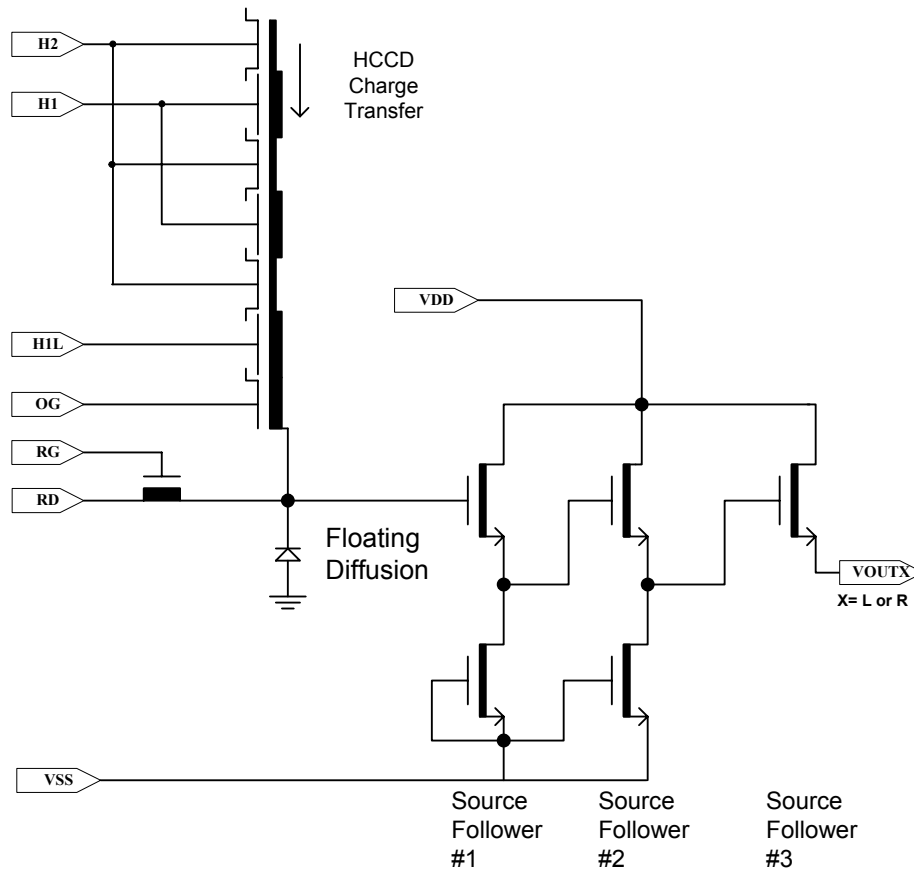

Figure 2: Output Architecture (Left or Right)

The output consists of a floating diffusion capacitance connected to a three-stage source follower. Charge presented to the floating diffusion (FD) is converted into a voltage and is current amplified in order to drive off-chip loads. The resulting voltage change seen at the output is linearly related to the amount of charge placed on the FD. Once the signal has been sampled by the system

electronics, the reset gate (RG) is clocked to remove the signal and FD is reset to the potential applied by reset drain (RD). Increased signal at the floating diffusion reduces the voltage seen at the output pin. To activate the output structure, an off-chip current source must be added to the VOUT pin of the device. See Figure 3.

Output Load

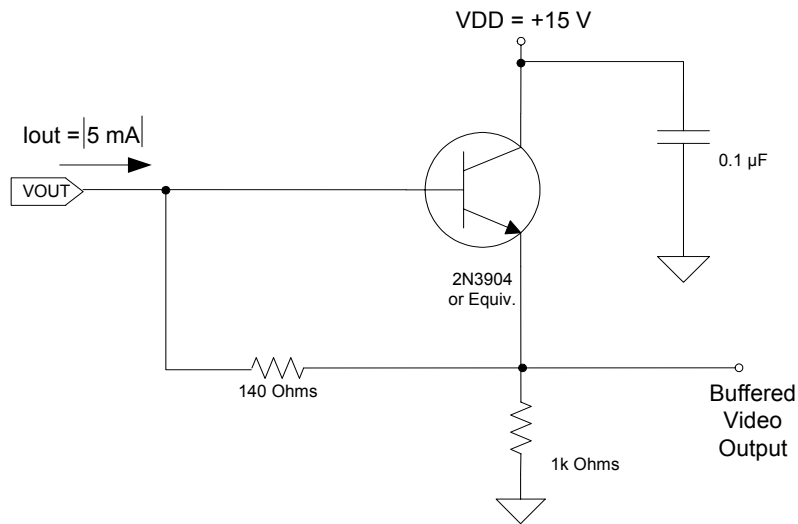

Figure 3: Recommended Output Structure Load Diagram.

Note: Component values may be revised based on operating conditions and other design considerations.

PHYSICAL DESCRIPTION

Pin Description and Device Orientation

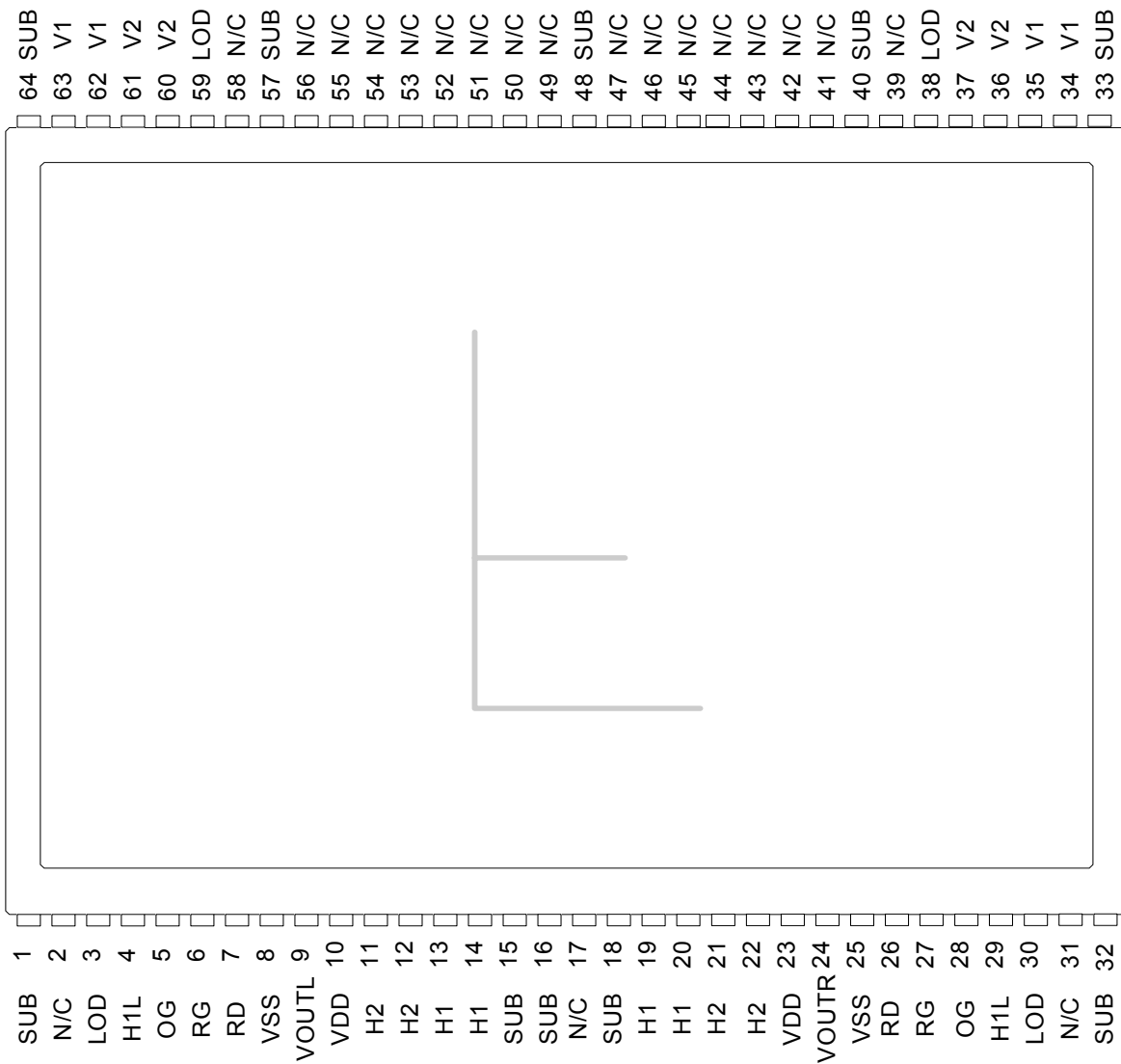

Figure 4: Pinout Diagram

Note: Pins with the same name are to be tied together on the circuit board and have the same timing.

Pin	Name	Description
1	SUB	Substrate
2	N/C	No Connection
3	LOD	Lateral Overflow Drain
4	H1L	Horizontal Phase 1, Last Gate
5	OG	Output Gate
6	RG	Reset Gate
7	RD	Reset Drain
8	VSS	Output Amplifier Return
9	VOU TL	Video Output: Left
10	VDD	Output Amplifier Supply
11	H2	Horizontal Phase 2
12	H2	Horizontal Phase 2
13	H1	Horizontal Phase 1
14	H1	Horizontal Phase 1
15	SUB	Substrate
16	SUB	Substrate
17	N/C	No Connection
18	SUB	Substrate
19	H1	Horizontal Phase 1
20	H1	Horizontal Phase 1
21	H2	Horizontal Phase 2
22	H2	Horizontal Phase 2
23	VDD	Output Amplifier Supply
24	VOU TR	Video Output: Right
25	VSS	Output Amplifier Return
26	RD	Reset Drain
27	RG	Reset Gate
28	OG	Output Gate
29	H1L	Horizontal Phase 1, Last Gate
30	LOD	Lateral Overflow Drain
31	N/C	No Connection
32	SUB	Substrate

Pin	Name	Description
64	SUB	Substrate
63	V1	Vertical Phase 1
62	V1	Vertical Phase 1
61	V2	Vertical Phase 2
60	V2	Vertical Phase 2
59	LOD	Lateral Overflow Drain
58	N/C	No Connection
57	SUB	Substrate
56	N/C	No Connection
55	N/C	No Connection
54	N/C	No Connection
53	N/C	No Connection
52	N/C	No Connection
51	N/C	No Connection
50	N/C	No Connection
49	N/C	No Connection
48	SUB	Substrate
47	N/C	No Connection
46	N/C	No Connection
45	N/C	No Connection
44	N/C	No Connection
43	N/C	No Connection
42	N/C	No Connection
41	N/C	No Connection
40	SUB	Substrate
39	N/C	No Connection
38	LOD	Lateral Overflow Drain
37	V2	Vertical Phase 2
36	V2	Vertical Phase 2
35	V1	Vertical Phase 1
34	V1	Vertical Phase 1
33	SUB	Substrate

Note: The leads are on a 0.070" spacing

IMAGING PERFORMANCE

TYPICAL OPERATIONAL CONDITIONS

Description	Condition - Unless otherwise noted	Notes
Frame time ($t_{\text{readout}} + t_{\text{int}}$)	1327 ms	Includes overclock pixels
Integration time (t_{int})	250 ms	
Horizontal clock frequency	24 MHz	
Temperature	25°C	Room temperature
Mode	integrate – readout cycle	
Operation	Nominal operating voltages and timing with min. vertical pulse width $t_{\text{vw}} = 17 \mu\text{s}$	

SPECIFICATIONS

Description	Symbol	Min.	Nom.	Max.	Units	Notes	Sample ¹⁵ Plan
Saturation Signal	Vsat Ne ⁻ _{sat} Q/V	1300 54k	1560 60k 26		mV e ⁻ $\mu\text{V}/e^-$	1	die
Quantum Efficiency Red (610nm) Green (540nm) Blue (470nm)	QE _{max}		20 23 18		%QE %QE %QE		design
Quantum Efficiency Monochrome (560nm)	QE _{max}		30		%QE		design
High Level Photoresponse Non-Linearity	PRNL		5	10	%	2	die
(color version only) Photo Response Non-Uniformity	PRNU r,g,b		10	20	%p-p	3	die
Readout Dark Current	Vdark,read		4	10	mV	5	die
Integration Dark Signal	Vdark,int		6.5	20	mV/s	4	die
Dark Signal Non-Uniformity	DSNU		2	8	mV p-p	6	die
Dark Signal Doubling Temperature	ΔT		6.3		°C		design
Read Noise	NR		16	40	e ⁻ rms		die
Total Noise	N		21		e ⁻ rms	7	design
Linear Dynamic Range	DR		71.4		dB	8	design
(color version only) Red-Green Hue Shift Blue-Green Hue Shift	RGHueUnif BGHueUnif		6	12	%	9	die
Horizontal Charge Transfer Efficiency	HCTE		0.999995			10	die
Vertical Charge Transfer Efficiency	VCTE		0.999999				die
Blooming Protection	X_ab	250	1000		x Esat	11	design
DC Offset, output amplifier	Vodc	7.5	8.5	9.5	V	12	die
Output Amplifier Bandwidth	f _{-3dB}	80	114	122	MHz	13	design
Output Impedance, Amplifier	ROUT	130	140	200	Ohms		die
Reset Feedthrough	V _{rft}		1		V	14	design

Notes:

1. Increasing output load currents to improve bandwidth will decrease these values.
2. Worst-case deviation (from 10 mV to V_{sat} min), relative to a linear fit applied between 0 and 65% of V_{sat} .
3. Difference between the maximum and minimum average signal levels of 146 x 146 blocks within the sensor on a per color basis as a % of average signal level.
4. $T=60^{\circ}\text{C}$. Average non-illuminated signal with respect to over-clocked vertical register signal.
5. $T=60^{\circ}\text{C}$, 24MHz pixel rate, readout time=900 ms
6. $T=60^{\circ}\text{C}$. Absolute difference between the maximum and minimum average signal levels of 146 x 146 blocks within the sensor.
7. rms deviation of a multi-sampled pixel measured in the dark including amplifier and dark current shot noise.
8. $20\log(V_{sat}/V_N)$ - see Note 6 and note 1. $V_N = NR * Q/V$.
9. Gradual variations in hue (red with respect to green pixels and blue with respect to green pixels) in regions of interest (146 x 146 blocks) within the sensor. The specification refers to the largest value of the response difference imaged in Daylight 5500 K.
10. Measured per transfer at V_{sat} min. Typically, no degradation in CTE is observed up to 24 MHz.
11. X_{ab} is the number of times above the V_{sat} illumination level that the sensor will bloom by spot size doubling. The spot size is 10% of the imager height. X_{ab} is measured at 4ms.
12. Video level offset with respect to ground
13. Last stage only. Assumes 10 pF off-chip load.
14. Amplitude of feed-through pulse in VOUT due to RG coupling.
15. "Die" indicates a parameter that is measured on every sensor during the production testing. "Design" designates a parameter that is quantified during the design verification activity.

TYPICAL PERFORMANCE CURVES

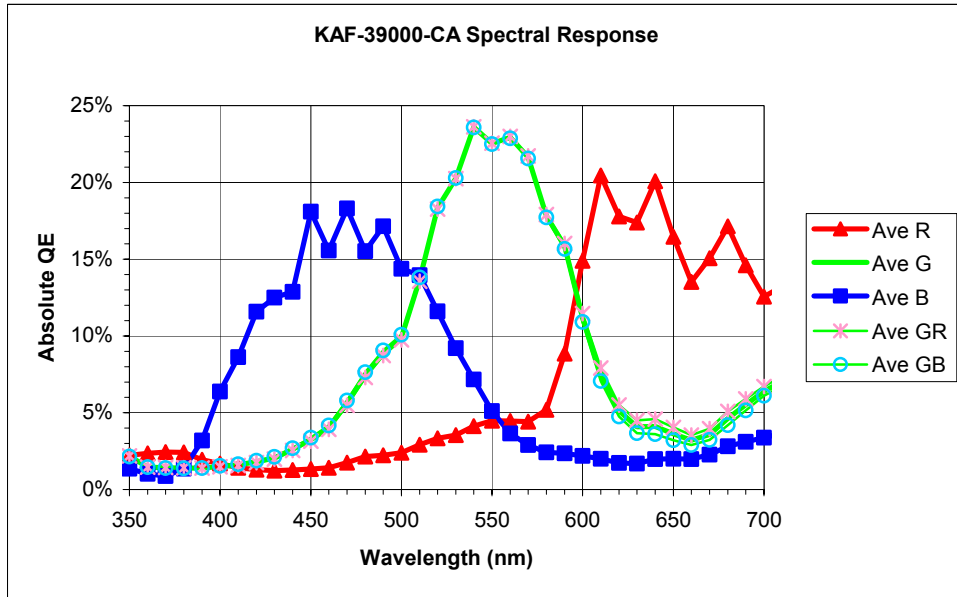

Figure 5: Spectral Response (color version)

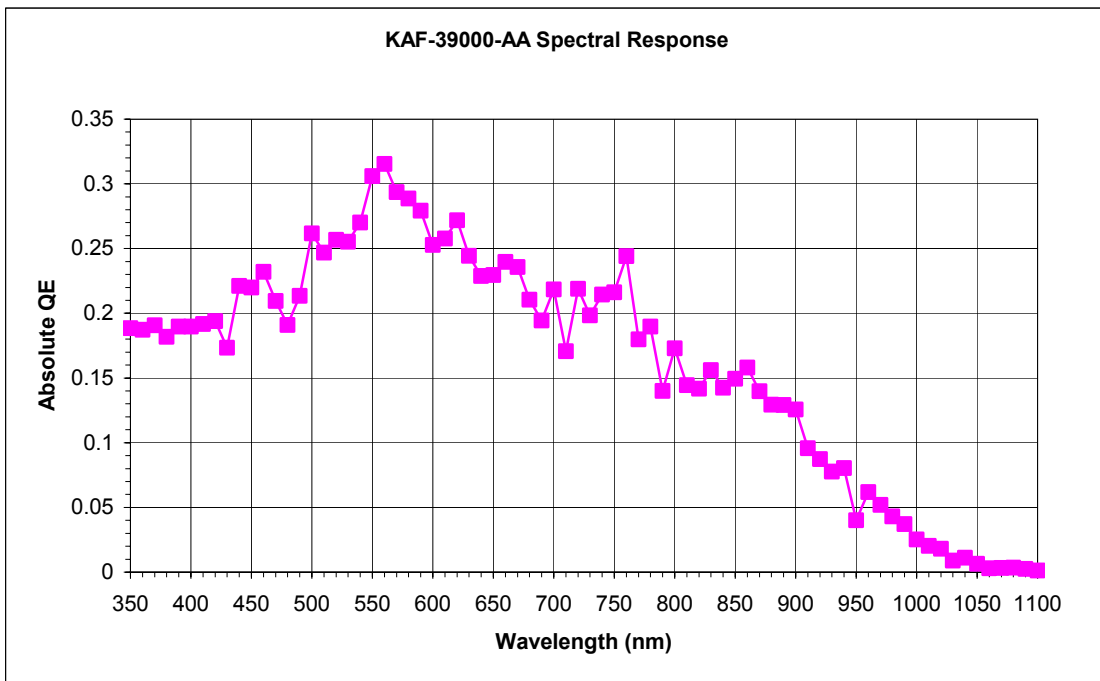

Figure 6: Spectral Response (monochrome version)

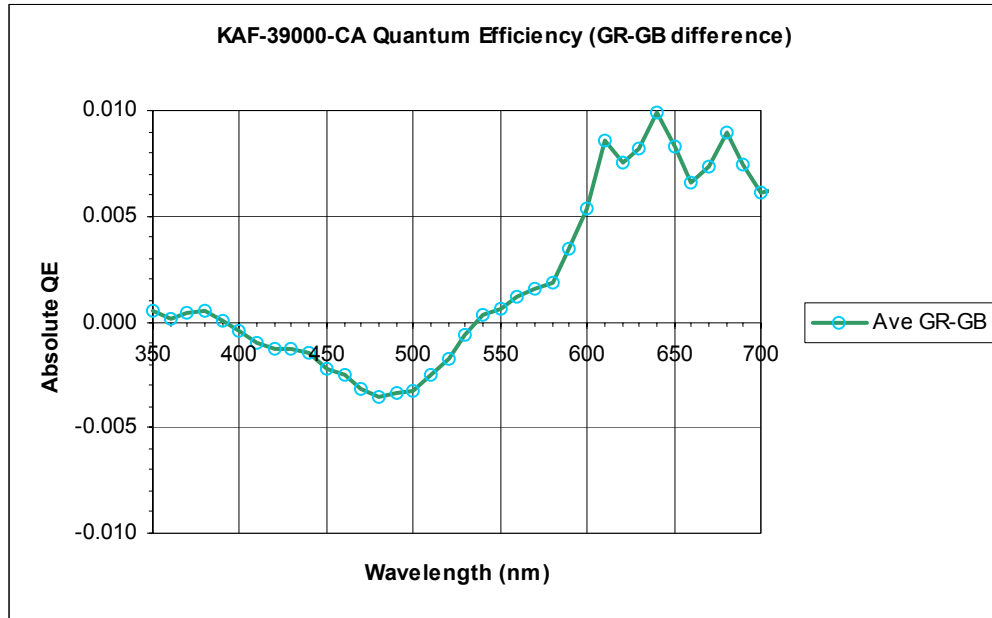

Figure 7: Typical GR - GB QE Difference (color version)

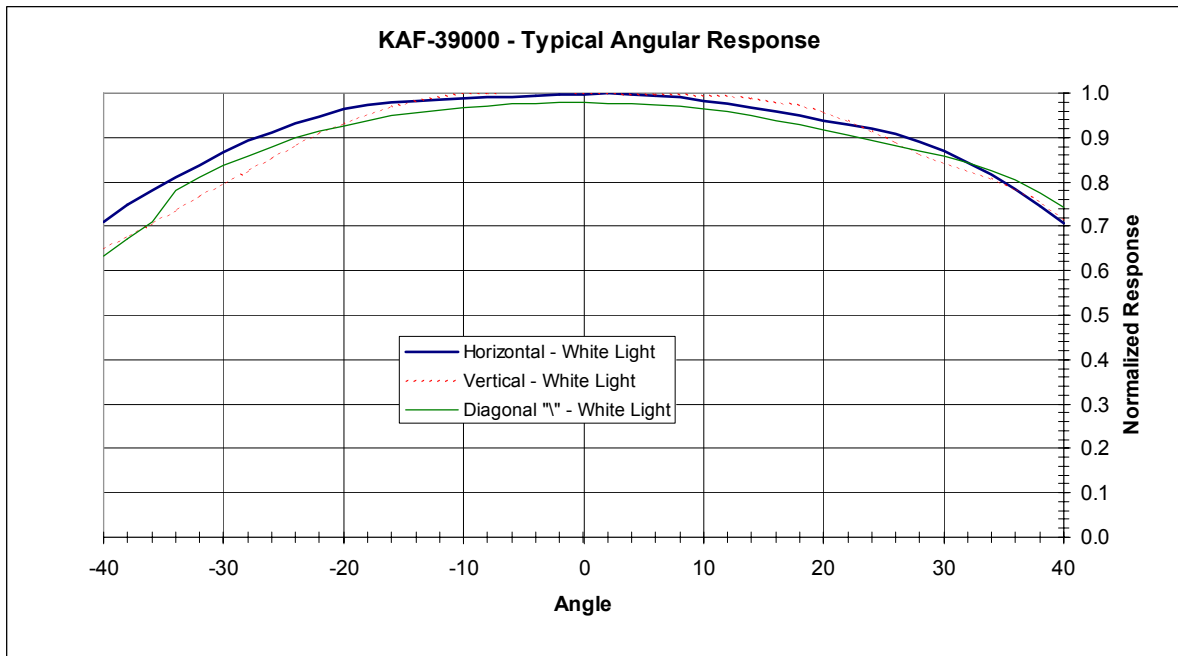

Figure 8: Typical Normalized Angle QE (both color and monochrome versions)

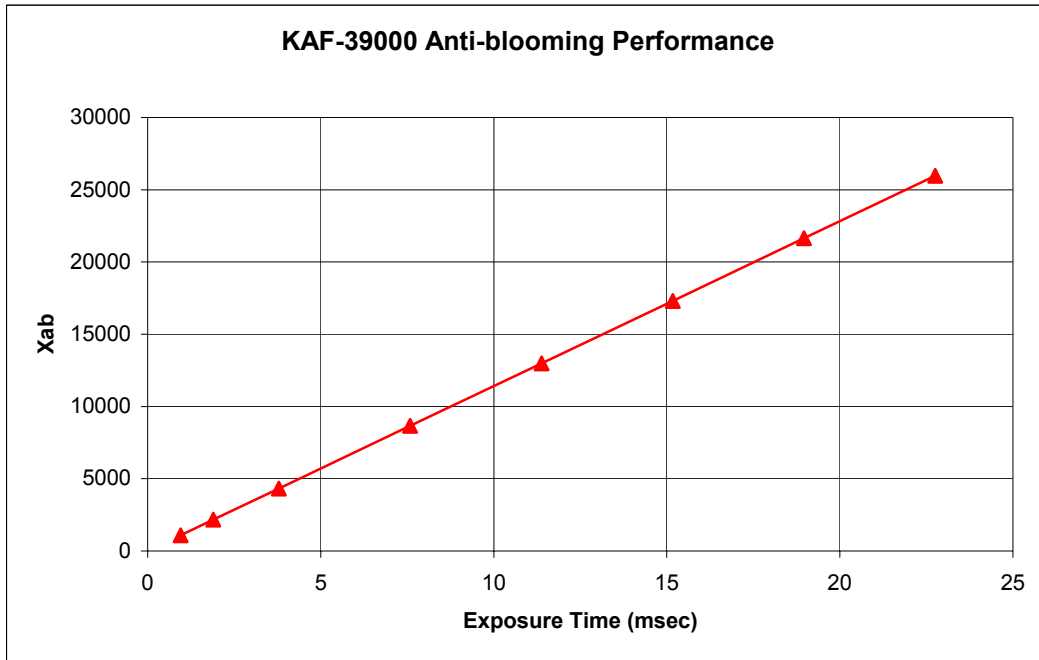

Figure 9: Typical Anti-blooming Performance

DEFECT DEFINITIONS

OPERATIONAL CONDITIONS

All defect tests performed at $T \sim 25^\circ\text{C}$, $t_{\text{int}} = 250 \text{ ms}$ and $t_{\text{readout}} = 1077 \text{ ms}$

SPECIFICATIONS

Classification	Points	Clusters	Columns	Includes dead columns
Standard Grade	<4,000	<50	<20	yes

Point Defects	<p>A pixel that deviates by more than 9 mV above neighboring pixels under non-illuminated conditions</p> <p>-- OR --</p> <p>A pixel that deviates by more than 7% above or 11% below neighboring pixels under illuminated conditions</p>
Cluster Defect	<p>A grouping of not more than 10 adjacent point defects</p> <p>Cluster defects are separated by no less than 4 good pixels in any direction</p>
Column Defect	<p>A grouping of more than 10 point defects along a single column</p> <p>-- OR --</p> <p>A column that deviates by more than 0.9 mV above or below neighboring columns under non-illuminated conditions</p> <p>-- OR --</p> <p>A column that deviates by more than 1.5% above or below neighboring columns under illuminated conditions</p> <p>Column defects are separated by no less than 4 good columns. No multiple column defects (double or more) will be permitted.</p> <p>Column and cluster defects are separated by at least 4 good columns in the x direction.</p>
Dead Columns	<p>A column that deviates by more than 50% below neighboring columns under illuminated conditions</p>
Saturated Columns	<p>A column that deviates by more than 100 mV above neighboring columns under non-illuminated conditions. No saturated columns are allowed.</p>

OPERATION

ABSOLUTE MAXIMUM RATINGS⁸

Description	Symbol	Minimum	Maximum	Units	Notes
Diode Pin Voltages	V_{diode}	-0.5	+17.5	V	1,2
Gate Pin Voltages	V_{gate1}	-13.5	+13.5	V	1,3
Overlapping Gate Voltages	V_{1-2}	-13.5	+13.5	V	4
Non-overlapping Gate Voltages	V_{g-g}	-13.5	+13.5	V	5
Output Bias Current	I_{out}		-30	mA	6
LODT Diode Voltage	V_{LODT}	-0.5	+13.0	V	7
Operating Temperature	T_{OP}	0	60	°C	9

Notes:

1. Referenced to pin VSUB
2. Includes pins: VRD, VDD, VSS, VOUT.
3. Includes pins: V1, V2, H1, H1L, H2, RG, VOG.
4. Voltage difference between overlapping gates. Includes: V1 to V2; H1, H1L to H2; H1L to VOG; V1 to H2.
5. Voltage difference between non-overlapping gates. Includes: V1 to H1, H1L; V2, VOG to H2.
6. Avoid shorting output pins to ground or any low impedance source during operation. Amplifier bandwidth increases at higher currents and lower load capacitance at the expense of reduced gain (sensitivity). Operation at these values will reduce MTTF.
7. V1, H1, V2, H2, H1L, VOG, and VRD are tied to 0 V.
8. Absolute maximum rating is defined as a level or condition that should not be exceeded at any time per the description. If the level or condition is exceeded, the device will be degraded and may be damaged.
9. Noise performance will degrade at higher temperatures.

POWER-UP SEQUENCE

The sequence chosen to perform an initial power-up is not critical for device reliability. A coordinated sequence may minimize noise and the following sequence is recommended:

1. Connect the ground pins (VSUB).
2. Supply the appropriate biases and clocks to the remaining pins.

DC BIAS OPERATING CONDITIONS

Description	Symbol	Minimum	Nominal	Maximum	Units	Maximum DC Current (mA)	Notes
Reset Drain	V _{RD}	11.3	11.5	11.7	V	I _{RD} = 0.01	
Output Amplifier Return	V _{SS}	0.5	0.7	1.0	V	I _{SS} = 3.0	
Output Amplifier Supply	V _{DD}	14.5	15.0	15.5	V	I _{OUT} + I _{SS}	
Substrate	V _{SUB}		0		V	0.01	
Output Gate	V _{OG}	-3.2	-3.0	-2.8	V	0.01	
Lateral Drain	V _{LOD}	9.8	10.0	10.2	V	0.01	
Video Output Current	I _{OUT}		-5	-10	mA		1

Note:

1. An output load sink must be applied to VOUT to activate output amplifier – see Figure 3.

AC OPERATING CONDITIONS

Clock Levels

Description	Symbol	Level	Minimum	Nominal	Maximum	Units	Effective Capacitance	Notes
V1 Low Level	V1L	Low	-9.2	-9.0	-8.8	V	360 nF	1
V1 High Level	V1H	High	2.3	2.5	2.7	V		1
V2 Low Level	V2L	Low	-9.2	-9.0	-8.8	V	440 nF	1
V2 High Level	V2H	High	2.3	2.5	2.7	V		1
H1 Low Level	H1L	Low	-4.7	-4.5	-4.3	V	550 pF	1
H1 High Level	H1H	High	2.5	2.7	2.9	V		1
H1L Low Level	H1L _{low}	Low	-6.7	-6.5	-6.3	V	13 pF	1
H1L High Level	H1L _{high}	High	2.5	2.7	2.9	V		1
H2 Low Level	H2L	Low	-5.2	-5.0	-4.8	V	370 pF	1
H2 High Level	H2H	High	2.0	2.2	2.4	V		1
RG Low Level	V _{RGL}	Low	0.3	0.5	0.7	V	13 pF	1
RG High Level	V _{RGH}	High	7.8	8.0	8.2	V		1

Note:

1. All pins draw less than 10 µA DC current. Capacitance values relative to SUB (substrate).

TIMING

REQUIREMENTS AND CHARACTERISTICS

Description	Symbol	Minimum	Nominal	Maximum	Units	Notes
H1, H2 Clock Frequency	f_H			24	MHz	1, 2
V1, V2 Clock Frequency	f_V			30	kHz	1, 2
H1, H2 Rise, Fall Times	t_{H1r}, t_{H1f}	5		10	%	3, 7
V1, V2 Rise, Fall Times	t_{V1r}, t_{V1f}	5		10	%	3
V1 - V2 Cross-over	V_{VCR}	-1	0	1	V	
H1 - H2 Cross-over	V_{HCR}	-2.8	-1.4	0	V	
Off Time	t_{off}	0	153		μs	
H1, H2 Setup Time	t_{HS}	1	5		μs	
RG Clock Pulse Width	t_{RGw}	5			ns	4
RG Rise, Fall Times	t_{RGr}, t_{RGf}	5		10	%	3
V1, V2 Clock Pulse Width	t_{Vw}	17	19		μs	2, 6, 9
Pixel Period (1 Count)	t_e	42	42		ns	2
H1L - VOUT Delay	t_{HV}		5		ns	
RG - VOUT Delay	t_{RV}		5		ns	
Readout Time	$t_{readout}$	1033	1077		ms	6, 8
Integration Time	t_{int}		-			5, 6
Line Time	t_{line}	188	181		μs	6
Fast Flush Time	t_{flush}	210	260		ms	

Notes:

1. 50% duty cycle values.
2. CTE will degrade above the nominal frequency.
3. Relative to the pulse width (based on 50% of high/low levels).
4. RG should be clocked continuously.
5. Integration time is user specified.
6. Longer times will degrade noise performance.
7. The maximum specification or 10ns whichever is greater based on the frequency of the horizontal clocks.
8. $t_{readout} = t_{line} * 5494$ lines.
9. Measured where Vclock is at 0 volts

EDGE ALIGNMENT

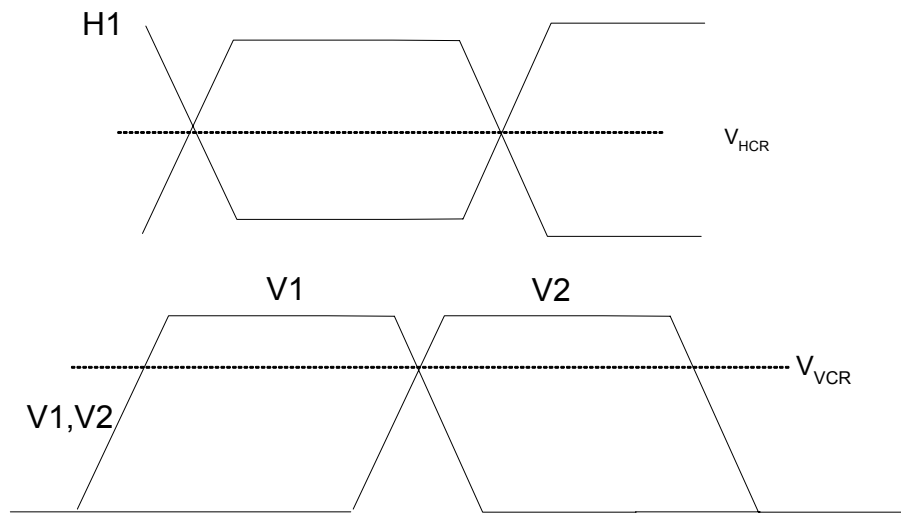

Figure 10: Timing Edge Alignment

FRAME TIMING

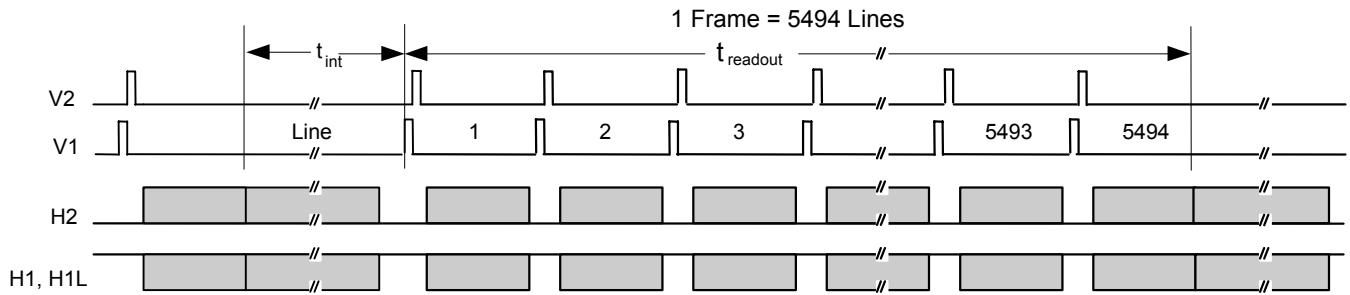

Figure 11: Frame Timing

Frame Timing Detail

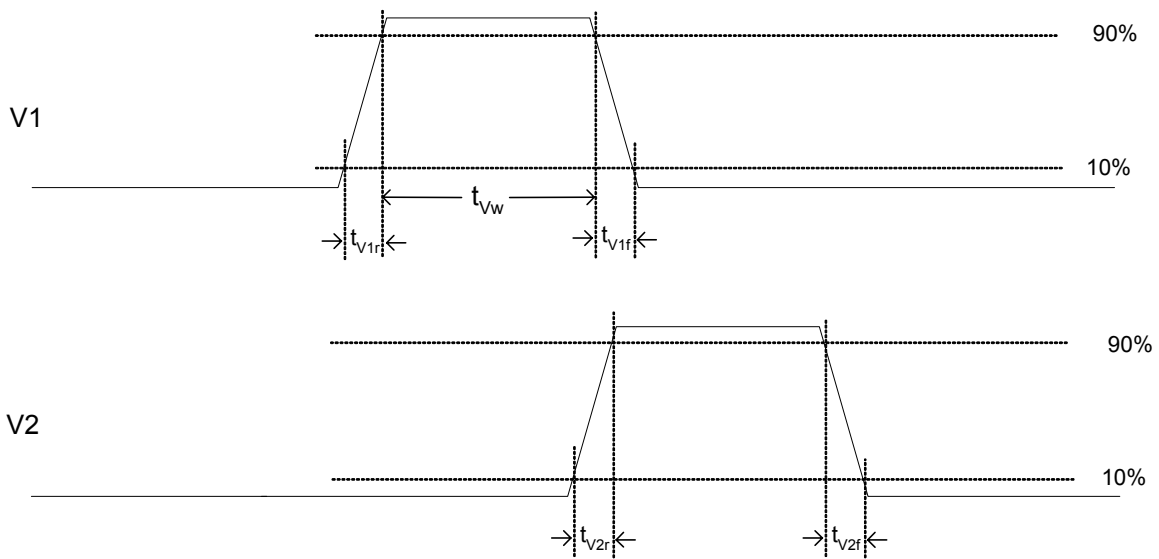

Figure 12: Frame Timing Detail

LINE TIMING (EACH OUTPUT)

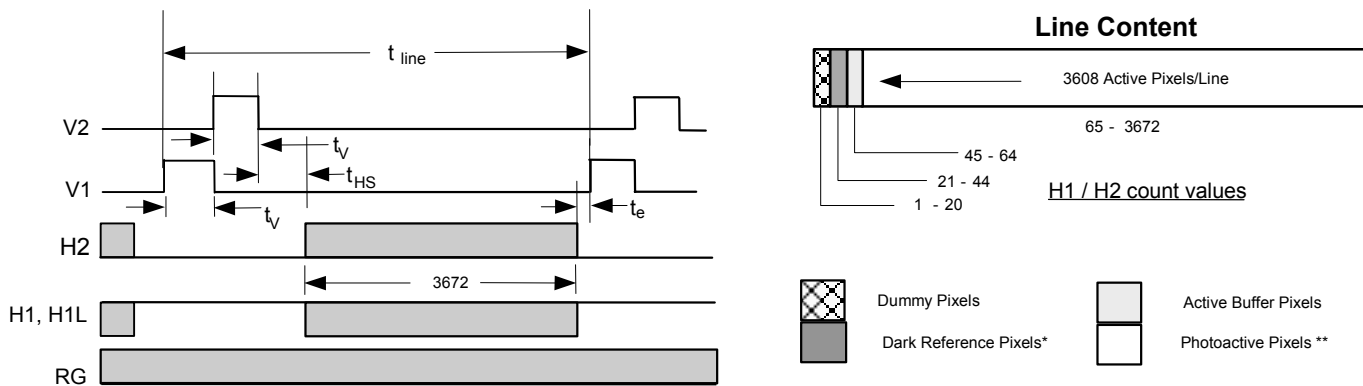

Figure 13: Line Timing

PIXEL TIMING

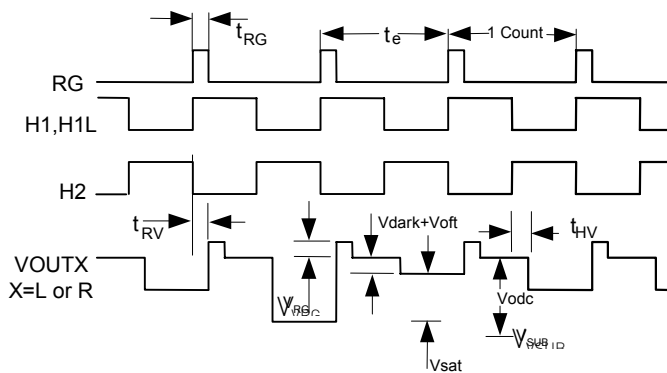

Figure 14: Pixel Timing

Pixel Timing Detail

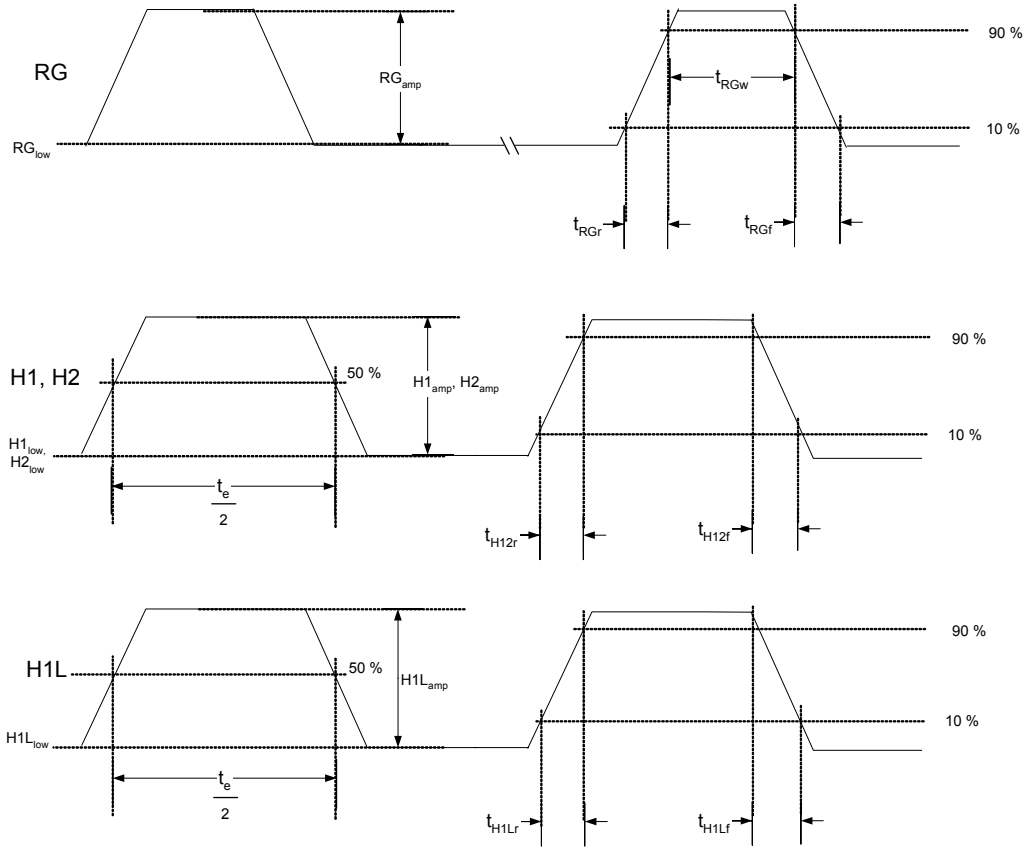

Figure 15: Pixel Timing Detail

MODE OF OPERATION

POWER-UP FLUSH CYCLE

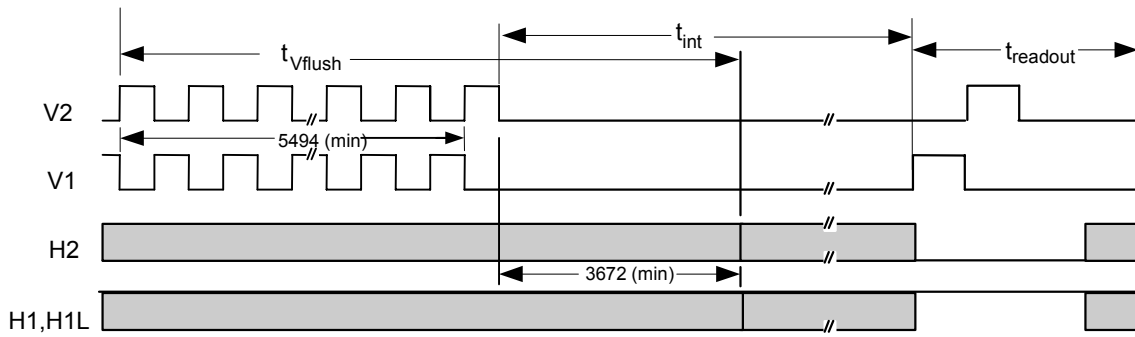

Figure 16: Power-up Flush Cycle

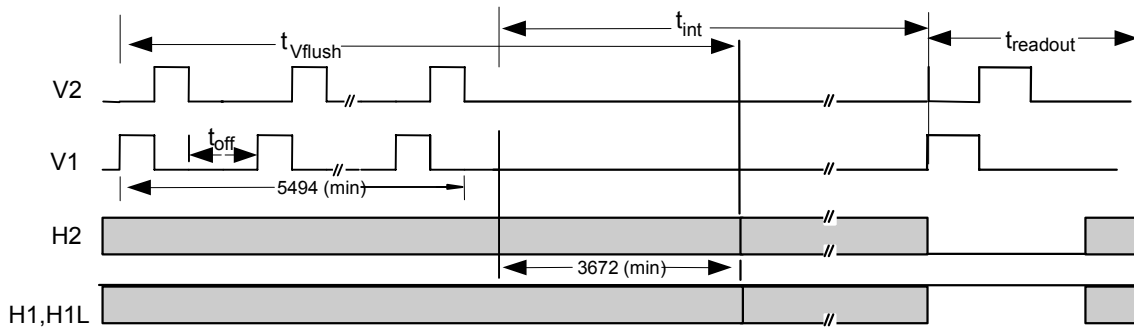

Figure 17: Modified (Slow) Flush Cycle

STORAGE AND HANDLING

STORAGE CONDITIONS

Description	Symbol	Minimum	Maximum	Units	Notes
Storage Temperature	T _{ST}	-20	70	°C	1

Notes:

1. Long-term storage toward the maximum temperature will accelerate color filter degradation.

ESD

1. This device contains limited protection against Electrostatic Discharge (ESD). CCD image sensors can be damaged by electrostatic discharge. Failure to do so may alter device performance and reliability.
2. Devices should be handled in accordance with strict ESD procedures for Class 0 (<250V per JESD22 Human Body Model test), or Class A (<200V JESD22 Machine Model test) devices. Devices are shipped in static-safe containers and should only be handled at static-safe workstations.
3. See Application Note MTD/PS-0224 "Electrostatic Discharge Control for Image Sensors" for proper handling and grounding procedures. This application note also contains recommendations for workplace modifications for the minimization of electrostatic discharge.
4. Store devices in containers made of electro-conductive materials.

COVER GLASS CARE AND CLEANLINESS

1. The cover glass is highly susceptible to particles and other contamination. Perform all assembly operations in a clean environment.
2. Touching the cover glass must be avoided.
3. Improper cleaning of the cover glass may damage these devices. Refer to Application

Note MTD/PS-0237 "Cover Glass Cleaning for Image Sensors".

ENVIRONMENTAL EXPOSURE

1. Do not expose to strong sun light for long periods of time. On the color version of this device, the color filters may become discolored. Long time exposures to a static high contrast scene should be avoided. The image sensor may become discolored and localized changes in response may occur from color filter aging.
2. Exposure to temperatures exceeding the absolute maximum levels should be avoided for storage and operation. Failure to do so may alter device performance and reliability.
3. Avoid sudden temperature changes.
4. Exposure to excessive humidity will affect device characteristics and should be avoided. Failure to do so may alter device performance and reliability.
5. Avoid storage of the product in the presence of dust or corrosive agents or gases. Long-term storage should be avoided. Deterioration of lead solderability may occur. It is advised that the solderability of the device leads be re-inspected after an extended period of storage, over one year.

SOLDERING RECOMMENDATIONS

1. The soldering iron tip temperature is not to exceed 370°C. Failure to do so may alter device performance and reliability.
2. Flow soldering method is not recommended. Solder dipping can cause damage to the glass and harm the imaging capability of the device. Recommended method is by partial heating. Kodak recommends the use of a grounded 30W soldering iron. Heat each pin for less than 2 seconds duration.

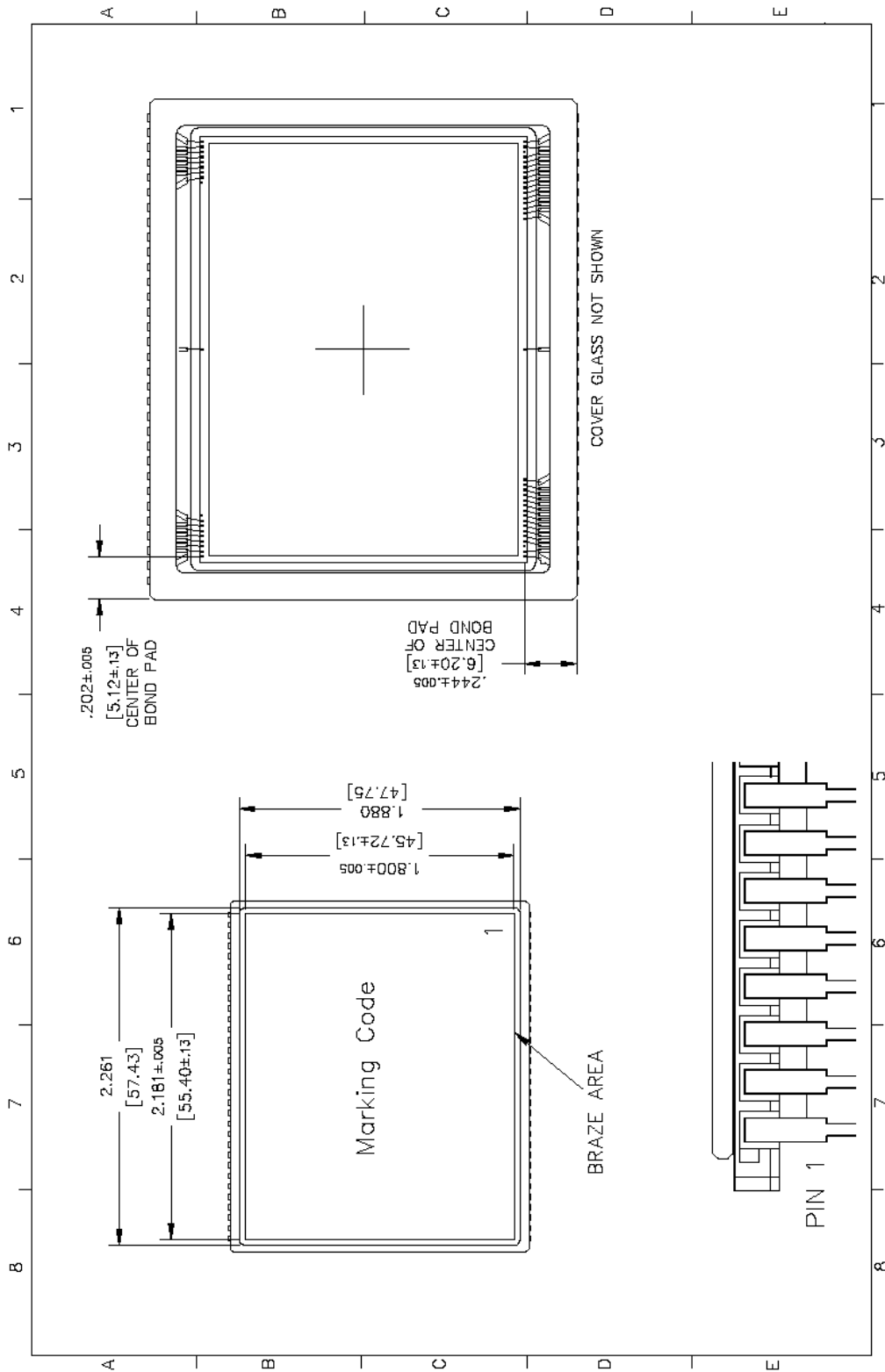

Figure 19: Completed Assembly Drawing (2 of 2)

COVER GLASS SPECIFICATION

1. Scratch and dig: 10 micron max
2. Substrate material Schott D-263
3. Multilayer anti-reflective coating

Wavelength	Total Reflectance
420-450	$\leq 2\%$
450-630	$\leq 1\%$
630-680	$\leq 2\%$

QUALITY ASSURANCE AND RELIABILITY

QUALITY STRATEGY:

All image sensors will conform to the specifications stated in this document. This will be accomplished through a combination of statistical process control and inspection at key points of the production process. Typical specification limits are not guaranteed but provided as a design target. For further information refer to ISS Application Note MTD/PS-0292, Quality and Reliability.

REPLACEMENT:

All devices are warranted against failure in accordance with the terms of Terms of Sale. This does not include failure due to mechanical and electrical causes defined as the liability of the customer below.

LIABILITY OF THE SUPPLIER:

A reject is defined as an image sensor that does not meet all of the specifications in this document upon receipt by the customer.

LIABILITY OF THE CUSTOMER:

Damage from mechanical (scratches or breakage), electrostatic discharge (ESD) damage, or other electrical misuse of the device beyond the stated absolute maximum ratings, which occurred after receipt of the sensor by the customer, shall be the responsibility of the customer.

RELIABILITY:

Information concerning the quality assurance and reliability testing procedures and results are available from the Image Sensor Solutions and can be supplied upon request. For further information refer to ISS Application Note MTD/PS-0292, Quality and Reliability.

TEST DATA RETENTION:

Image sensors shall have an identifying number traceable to a test data file. Test data shall be kept for a period of 2 years after date of delivery.

MECHANICAL:

The device assembly drawing is provided as a reference. The device will conform to the published package tolerances.

Kodak reserves the right to change any information contained herein without notice. All information furnished by Kodak is believed to be accurate.

WARNING: LIFE SUPPORT APPLICATIONS POLICY

Kodak image sensors are not authorized for and should not be used within Life Support Systems without the specific written consent of the Eastman Kodak Company. Product warranty is limited to replacement of defective components and does not cover injury or property or other consequential damages.

REVISION CHANGES

Revision Number	Description of Changes
1.0	Initial Release.
2.0	New specification format. Corrected pin out diagram and package information. Update Performance Table, T_{vw} , Frame Time, dark signal components identified. Updated fast flush time. Added anti blooming performance plot. Added min/max values for performance parameters. Changed name from KAF-39000CE to KAF-39000.
3.0	Converted new specification format. Added Quantum Efficiency (KAF-39000-AAA) parameter to the Summary Specification table.

