

Features:

- Developed short body length to 5 m/m, for the demand of smaller and thinner electronic equipment
- Most suitable for high-density electronic equipment, such as: automatic office machines, pocket calculators, car stereos and mini-audio sets, VCR, camera, CD-ROM, notebook

Specifications:

Item	Performance																								
Operating temperature range	-40°C to +85°C																								
Rated working voltage range	4 to 50 V dc																								
Nominal capacitance range	0.1 to 470 μ F																								
Capacitance tolerance	\pm 20% (at +20°C, 120 Hz)																								
Leakage current	$I = 0.01CV$ or 3(μ A) after two minutes																								
Dissipation factor ($\tan \delta$) (120 Hz \backslash +20°C)	<table border="1"> <thead> <tr> <th>Working voltage (V)</th> <th>4</th> <th>6.3</th> <th>10</th> <th>16</th> <th>25</th> <th>35</th> <th>50</th> </tr> </thead> <tbody> <tr> <td>Maximum $\tan \delta$</td> <td>0.35</td> <td>0.24</td> <td>0.2</td> <td>0.16</td> <td>0.14</td> <td>0.12</td> <td>0.1</td> </tr> </tbody> </table>	Working voltage (V)	4	6.3	10	16	25	35	50	Maximum $\tan \delta$	0.35	0.24	0.2	0.16	0.14	0.12	0.1								
	Working voltage (V)	4	6.3	10	16	25	35	50																	
Maximum $\tan \delta$	0.35	0.24	0.2	0.16	0.14	0.12	0.1																		
Characteristics at high and low temperature (stability at 120 Hz)	<table border="1"> <thead> <tr> <th>Working voltage (V)</th> <th>4</th> <th>6.3</th> <th>10</th> <th>16</th> <th>25</th> <th>35</th> <th>50</th> </tr> </thead> <tbody> <tr> <td>-25°C /+20°C</td> <td>7</td> <td>4</td> <td>3</td> <td>2</td> <td>2</td> <td>2</td> <td>2</td> </tr> <tr> <td>-40°C /+20°C</td> <td>15</td> <td>8</td> <td>6</td> <td>4</td> <td>4</td> <td>3</td> <td>3</td> </tr> </tbody> </table>	Working voltage (V)	4	6.3	10	16	25	35	50	-25°C /+20°C	7	4	3	2	2	2	2	-40°C /+20°C	15	8	6	4	4	3	3
	Working voltage (V)	4	6.3	10	16	25	35	50																	
	-25°C /+20°C	7	4	3	2	2	2	2																	
-40°C /+20°C	15	8	6	4	4	3	3																		
High temperature loading	<p>After 1,000 hours application of DC rated working voltage at +85°C, The capacitor shall meet the following limits : Post test requirements at +20°C</p> <table border="1"> <tbody> <tr> <td>Leakage current</td> <td>\leq the initial specified value</td> </tr> <tr> <td>Capacitance change</td> <td>$\leq \pm$20% of initial measured value</td> </tr> <tr> <td>Dissipation factor ($\tan \delta$)</td> <td>\leq 200% of initial specified value</td> </tr> </tbody> </table>	Leakage current	\leq the initial specified value	Capacitance change	$\leq \pm$ 20% of initial measured value	Dissipation factor ($\tan \delta$)	\leq 200% of initial specified value																		
Leakage current	\leq the initial specified value																								
Capacitance change	$\leq \pm$ 20% of initial measured value																								
Dissipation factor ($\tan \delta$)	\leq 200% of initial specified value																								
Shelf life	<p>After storage for 500 hours at +85°C with no voltage applied Post test requirements at +20°C same limits as high temperature loading</p>																								
Solvent proof	<p>This capacitor can withstand circuit-board cleaning within 5 minutes dipped in Freon TE, TES at 40°C (ultrasonic also permitted) or in the steam of these cleaners</p>																								

5mm 85°C MCUMR Series



Diagram of Dimensions

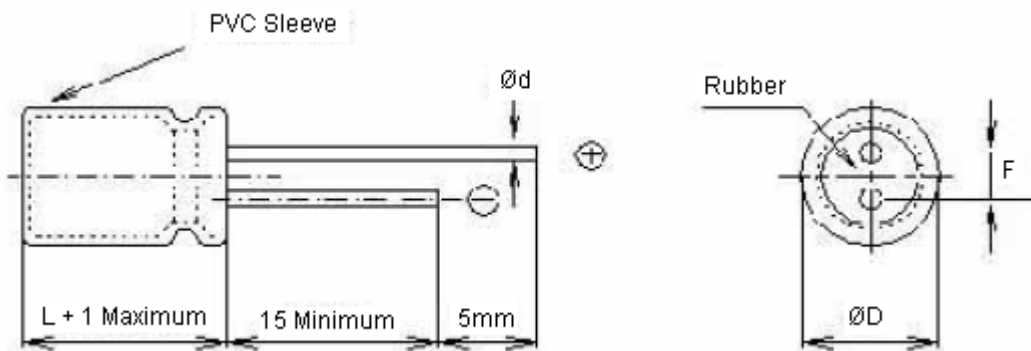

Dimensions : Millimetres

ØD (+0.5 Maximum)	3	4	5	6.3	8
F (±0.5)	1	1.5	2	2.5	3.5
Ød (±0.02)	0.4	0.45	0.45	0.45	0.5

Case Size Table ØD x L (mm)

W.V. (SV) \ µF	4 (5)	6.3 (8)	10 (13)	16 (20)	25 (32)	35 (44)	50 (63)
0.1	-	-	-	-	-	R	4 × 5 (3 × 5)
0.22	-	-	-	-	-		
0.33	-	-	-	-	-		
0.47	-	-	-	-	-		
1.0	-	-	-	-	-		
2.2	-	-	-	-	-		
3.3	-	-	-	-	R	4 × 5 (3 × 5)	4 × 5
4.7	-	-	-	R	4 × 5 (3 × 5)	4 × 5	5 × 5
10	-	-	R	4 × 5 (3 × 5)	4 × 5	5 × 5	6.3 × 5
22	R	4 × 5 (3 × 5)	4 × 5	4 × 5	5 × 5	6.3 × 5	8 × 5
33	4 × 5 (3 × 5)	4 × 5		5 × 5	6.3 × 5	6.3 × 5	8 × 5
47	R		5 × 5	6.3 × 5			
100		6.3 × 5	8 × 5	8 × 5	-	-	
220		8 × 5	-	-	-	-	-
330		8 × 5	-	-	-	-	-
470	8 × 5	-	-	-	-	-	-

3 × 5 = UM3R Series

All blank voltage on sleeve marking is the same voltage as "R" point to