



LOW THRESHOLD OCTAL HIGH SIDE DRIVER

General Features

Type	$R_{DS(on)}$	I_{out}	V_{CC}
VN808CM	160m Ω	0.7A	45V

- CMOS COMPATIBLE INPUT
- JUNCTION OVER-TEMPERATURE PROTECTION
- CASE OVER-TEMPERATURE PROTECTION FOR THERMAL INDEPENDENCE OF THE CHANNELS
- CURRENT LIMITATION
- SHORTED LOAD PROTECTIONS
- UNDERVOLTAGE SHUTDOWN
- PROTECTION AGAINST LOSS OF GROUND
- VERY LOW STAND-BY CURRENT
- COMPLIANCE TO 61000-4-4 IEC TEST UP TO 4KV

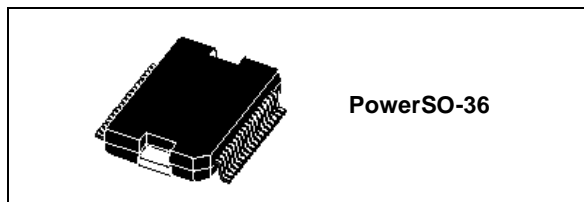

It can be driven by using a 3.3V logic supply. Active current limitation, combined with thermal shutdown and automatic restart, protect the device against overload. In overload condition, the channel turns OFF, then back ON automatically so as to maintain junction temperature between T_{TSD} and T_R . If this condition makes the case temperature reach T_{CSD} , the overloaded channel is turned OFF and will restart only when the case temperature has decreased down to T_{CR} (see Figures 6-7). Channels that are not overloaded continue to operate normally.

Description

The VN808CM is a monolithic device designed with STMicroelectronics VIPower M0-3 Technology, and is intended for driving any kind of load with one side connected to ground.

The device automatically turns OFF when the Ground pin is disconnected. This device is especially suitable for industrial applications which conform to IEC 61131 (Programmable Controllers International Standard)S

Block Diagram

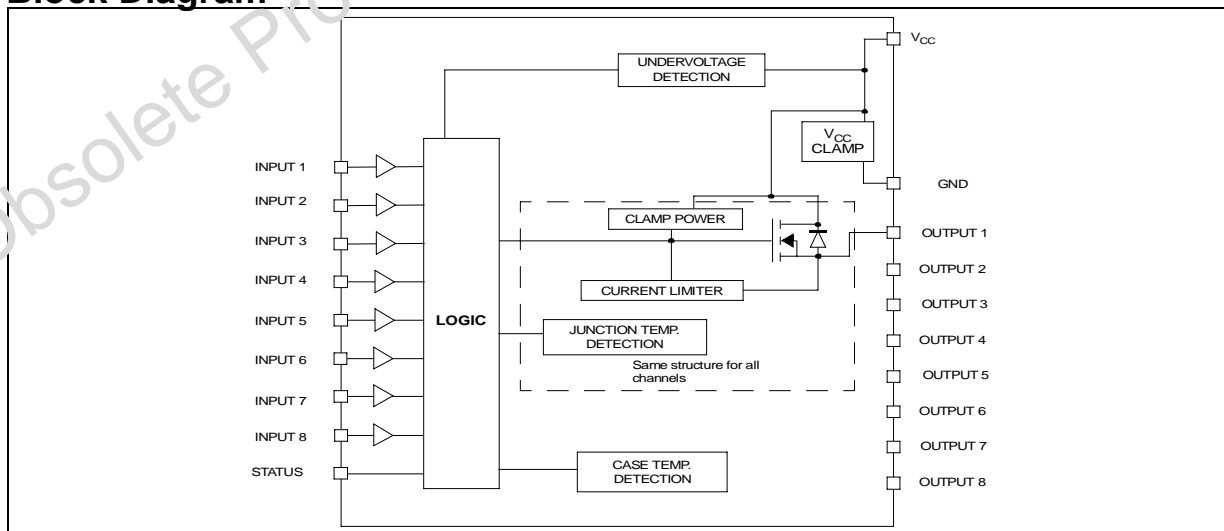

Table 1. Absolute Maximum Rating

Symbol	Parameter	Value	Unit
V_{CC}	DC Supply voltage	45	V
$-I_{GND}$	DC ground pin reverse current TRAN Ground pin reverse current (pulse duration < 1ms)	-250 -6	mA A
I_{OUT}	DC Output current	Internally limited	A
$-I_{OUT}$	Reverse DC output current	-2	A
I_{IN}	DC Input current	± 10	mA
V_{ESD}	Electrostatic discharge (R = 1.5KW; C = 100pF)	2000	V
P_{TOT}	Power dissipation at $T_C = 25^\circ\text{C}$	96	W
L_{MAX}	Max inductive load ($V_{CC} = 24\text{V}$, $R_{LOAD} = 48\Omega$, $T_A = 100^\circ\text{C}$)	2	H
T_J	Junction operating temperature	Internally limited	$^\circ\text{C}$
T_C	Case operating temperature	Internally limited	$^\circ\text{C}$
T_{STG}	Storage Temperature	-55 to 150	$^\circ\text{C}$

Table 2. Pin Definitions and Functions

Pin No.	Symbol	Function
TAB	V_{CC}	Positive power supply voltage
1	V_{CC}	Positive power supply voltage
2,3,4,5	NC	Not connected
6	Input 1	Input of channel 1
7	Input 2	Input of channel 2
8	Input 3	Input of channel 3
9	Input 4	Input of channel 4
10	Input 5	Input of channel 5
11	Input 6	Input of channel 6
12	Input 7	Input of channel 7
13	Input 8	Input of channel 8
14,15,16,17,18	NC	Not connected
19	GND	Logic ground
20	STATUS	Common open source diagnostic for over-temperature
21,22	Output 8	High-Side output of channel 8
23,24	Output 7	High-Side output of channel 7
25,26	Output 6	High-Side output of channel 6
27,28	Output 5	High-Side output of channel 5
29,30	Output 4	High-Side output of channel 4
31,32	Output 3	High-Side output of channel 3
33,34	Output 2	High-Side output of channel 2
35,36	Output 1	High-Side output of channel 1

Figure 1. Connection Diagram (Top View)

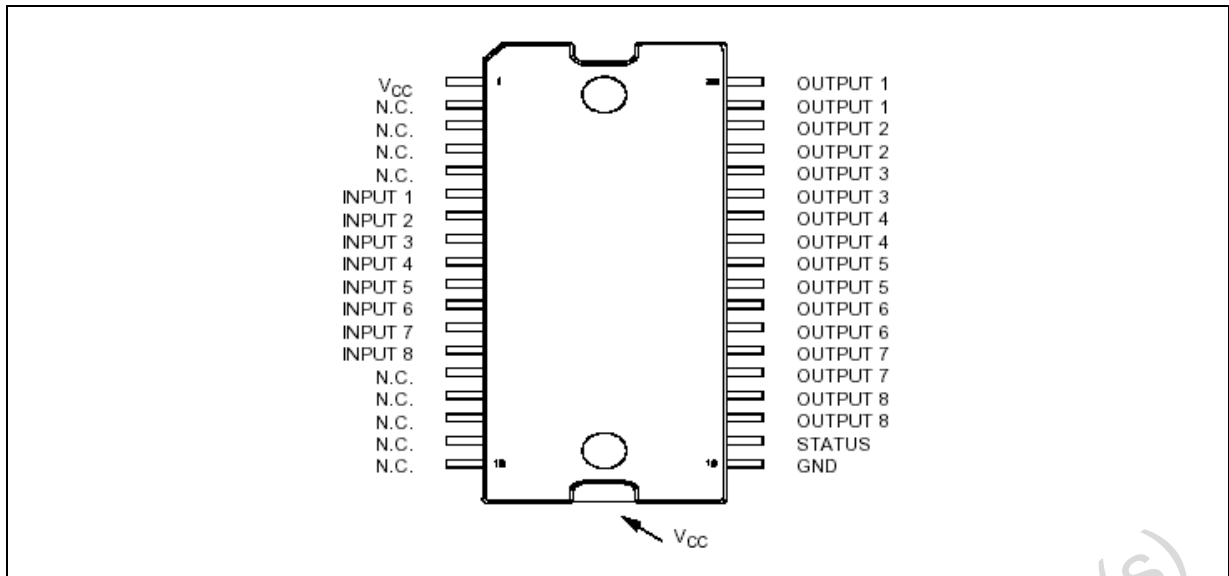
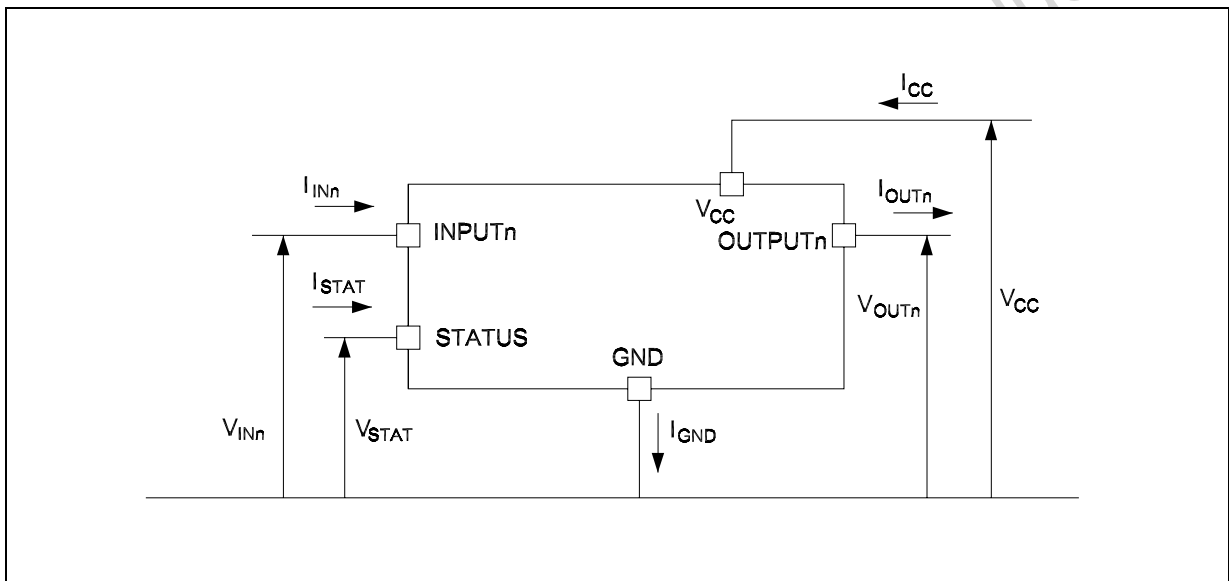

Figure 2. Current and Voltage Conventions



Obsolete

Table 3. Thermal data

Symbol	Parameter		Value	Unit
R_{thJC}	Thermal resistance junction-case	Max	1.3	°C/W
R_{thJA}	Thermal resistance junction-ambient <i>Note:1</i>	Max	50	°C/W

Note: 1. When mounted on FR4 printed circuit board with 0.5cm² of copper area (at least 35μ think) connected to all TAB pins.

Electrical Characteristics (10.5V < V_{CC} < 32V; -40°C < T_J < 125°C; unless otherwise specified)

Table 4. Power Section

Symbol	Parameter	Test Conditions	Min.	Typ.	Max.	Unit
V _{CC}	Operating supply voltage		10.5		45	V
V _{USD}	Undervoltage shutdown		7		10.5	V
R _{ON}	On state resistance	I _{OUT} = 0.5A; T _J = 25°C I _{OUT} = 0.5A;			160 280	mΩ mΩ
I _S	Supply current	OFF state; V _{CC} = 24V; T _{CASE} = 25°C ON state(all channels ON); V _{CC} = 24V T _{CASE} = 100°C			150 12	μA mA
I _{LGND}	Output current at turn-off	V _{CC} = V _{STAT} = V _{IN} = V _{GND} = 24V V _{OUT} = 0V			1	mA
I _{L(off)}	OFF state output current	V _{IN} = V _{OUT} = 0V;	0		5	μA
V _{OUT(off)}	OFF state output voltage	V _{IN} = 0V; I _{OUT} = 0A;			3	V
t _{d(Vccon)}	Power-on delay time from V _{CC} rising edge	<i>Figure 4.</i>		1		ms

Table 5. Switching (V_{CC} = 24V)

Symbol	Parameter	Test Conditions	Min.	Typ.	Max.	Unit
t _{ON}	Turn-on time	R _L = 48Ω from 80% V _{OUT} <i>Figure 3.</i>		50	100	μs
t _{OFF}	Turn-off time	R _L = 48Ω to 10% V _{OUT} <i>Figure 3.</i>		75	150	μs
dV _{OUT} /dt _(on)	Turn-on voltage slope	R _L = 48Ω from V _{OUT} = 2.4V to V _{OUT} = 19.2V <i>Figure 3.</i>		0.7		V/μs
dV _{OUT} /dt _(off)	Turn-off voltage slope	R _L = 48Ω from V _{OUT} = 21.6V to V _{OUT} = 2.4V <i>Figure 3.</i>		1.5		V/μs

Table 6. Input Pin

Symbol	Parameter	Test Conditions	Min.	Typ.	Max.	Unit
V_{INL}	Input low level				1.25	V
I_{INL}	Low level input current	$V_{IN} = 1.25V$	1			μA
V_{INH}	Input high level		2.25			V
I_{INH}	High level input current	$V_{IN} = 2.25V$			10	μA
$V_{I(HYST)}$	Input hysteresis voltage		0.25			V
V_{ICL}	Input Clamp Voltage	$I_{IN} = 1mA$	6.0	6.8	8.0	V
		$I_{IN} = -1mA$		-0.7		V

Table 7. Protections

Symbol	Parameter	Test Conditions	Min.	Typ.	Max.	Unit
T_{CSD}	Case shut-down temperature		125	130	135	$^{\circ}C$
T_{CR}	Case reset temperature		110			$^{\circ}C$
T_{CHYST}	Case thermal hysteresis		7	15		$^{\circ}C$
T_{TSD}	Junction shutdown temperature		150	175	200	$^{\circ}C$
T_R	Junction reset temperature		135			$^{\circ}C$
T_{HYST}	Junction thermal hysteresis		7	15		$^{\circ}C$
I_{lim}	DC Short circuit current	$V_{CC} = 24V; R_{LOAD} = 10m\Omega$	0.7		1.7	A
V_{demag}	Turn-off output clamp voltage	$I_{OUT} = 0.5A; L = 6mH$	$V_{CC}-57$	$V_{CC}-52$	$V_{CC}-47$	V

Table 8. Status Pin

Symbol	Parameter	Test Conditions	Min.	Typ.	Max.	Unit
I_{HSTAT}	High level output current	$V_{CC} = 18...32V; R_{STAT} = 1K\Omega$ (Fault condition)	2	3	4	mA
I_{LSTAT}	Leakage current	Normal operation; $V_{CC} = 32V$			0.1	μA
V_{CLSTAT}	Clamp voltage	$I_{STAT} = 1mA$	6.0	6.8	8.0	V
		$I_{STAT} = -1mA$		-0.7		V

Switching Time Waveforms

Figure 3. Turn-on & Turn-off

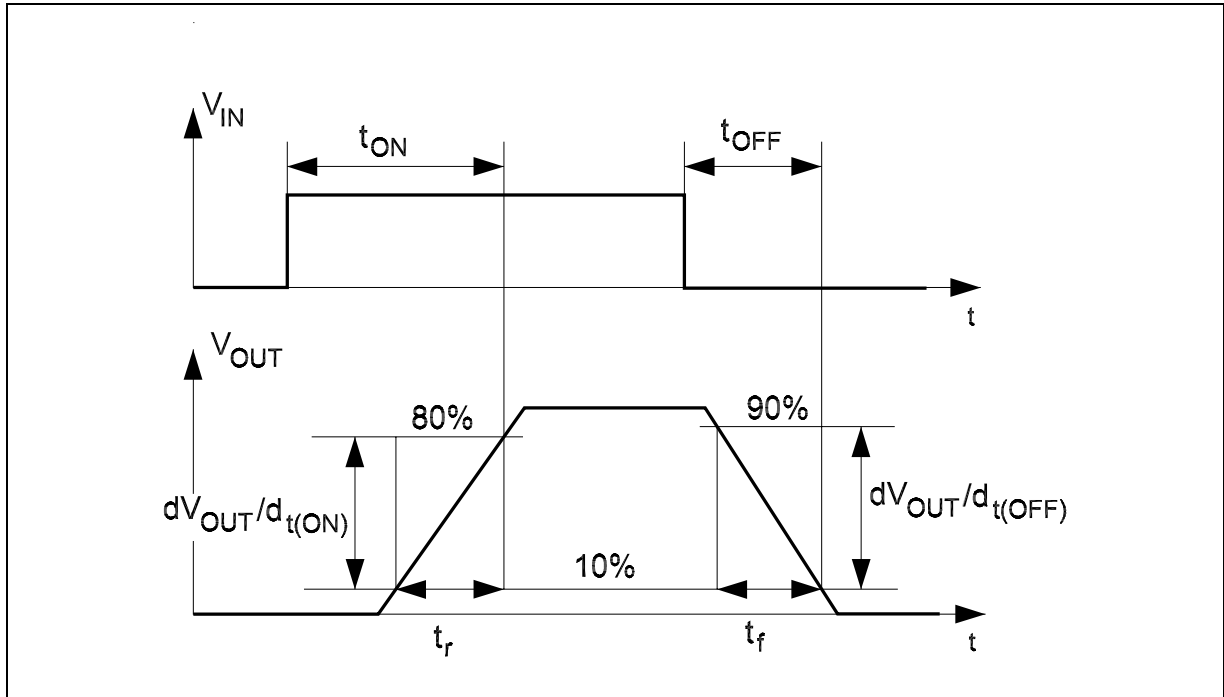

Figure 4. V_{CC} Turn-on

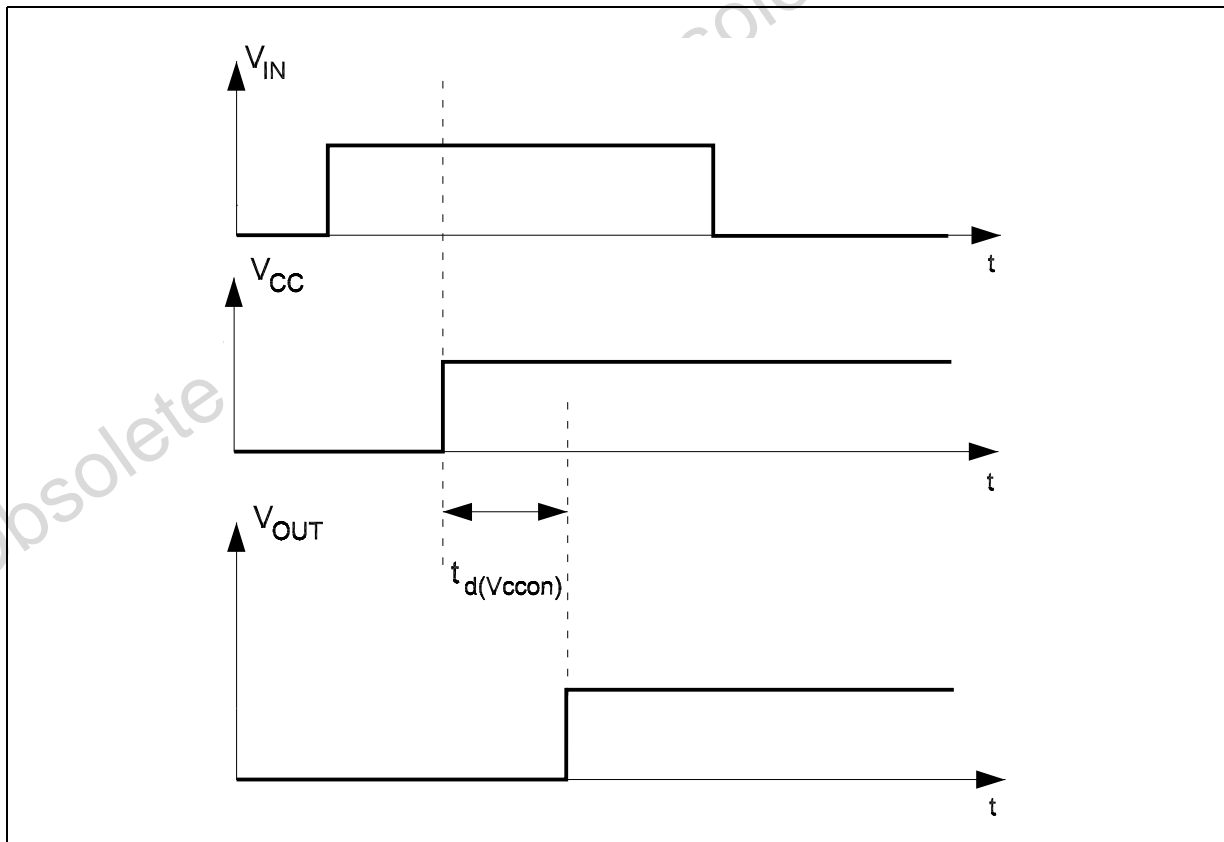

Table 9. Truth Table

Conditions	INPUTn	OUTPUTn	STATUS
Normal operation	L	L	L
	H	H	L
Current limitation	L	L	L
	H	X	L
Overtemperature (see waveforms 3, 4 Figure 6 . Figure 7 .) -> $T_J > T_{TSD}$	L	L	L
	H	L	H
Undervoltage	L	L	X
	H	L	X

Figure 5. Application Schematic

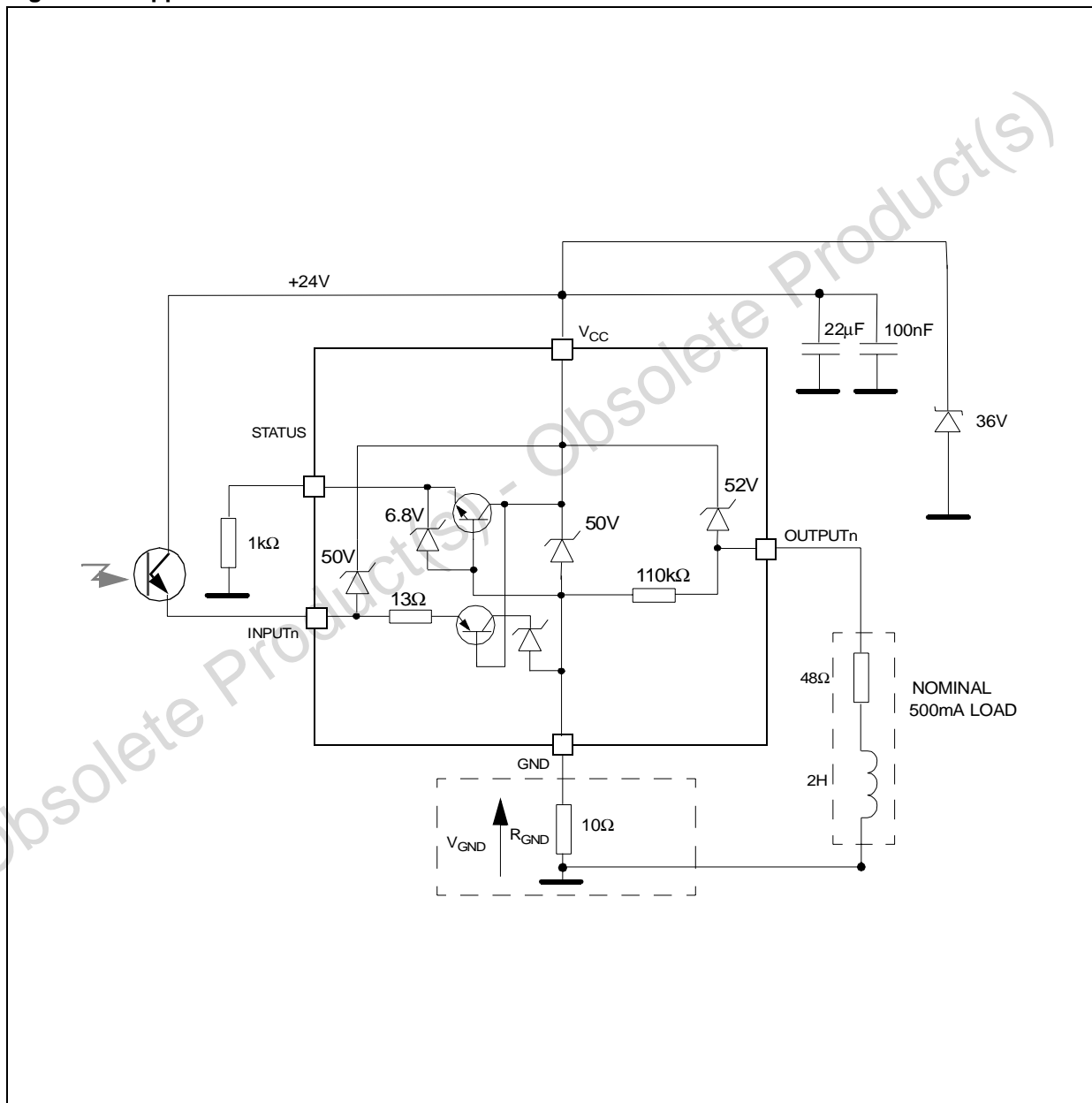

Figure 6. Waveforms

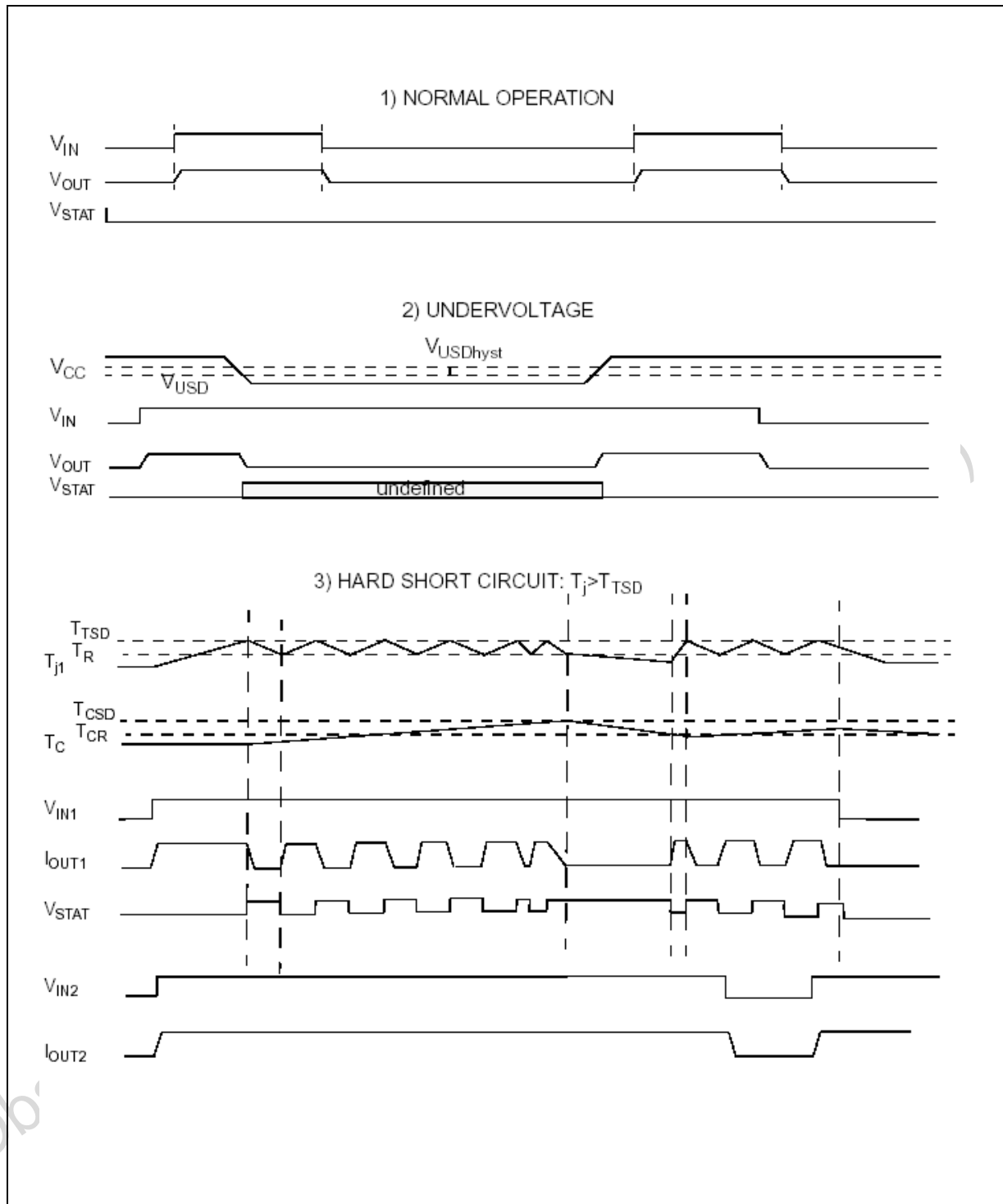
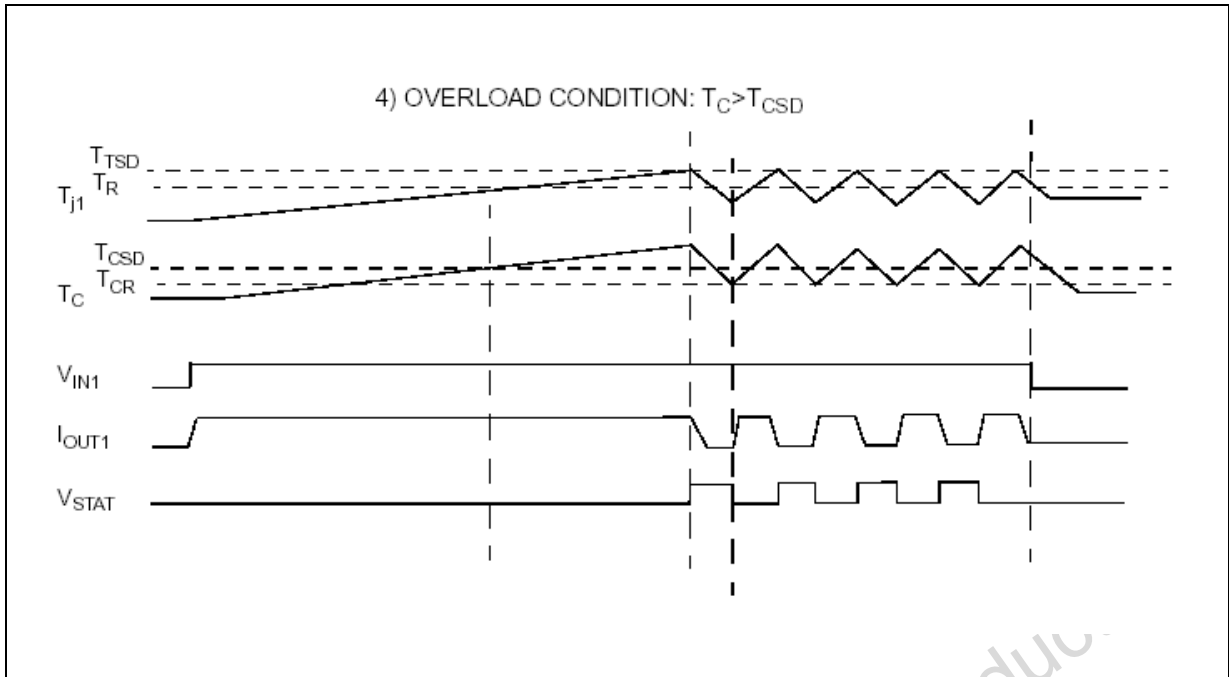

Figure 7. Waveforms (continued)



Obsolete Product(s) - Obsolete Product

Mechanical Data

In order to meet environmental requirements, ST offers these devices in ECOPACK® packages. These packages have a Lead-free second level interconnect . The category of second level interconnect is marked on the package and on the inner box label, in compliance with JEDEC Standard JESD97. The maximum ratings related to soldering conditions are also marked on the inner box label. ECOPACK is an ST trademark. ECOPACK specifications are available at: www.st.com

Obsolete Product(s) - Obsolete Product(s)

Table 10. PowerSO-36 Mechanical Data

DIM.	mm.			inch		
	MIN.	TYP	MAX.	MIN.	TYP.	MAX.
A			3.60			0.141
a1	0.10		0.30	0.004		0.012
a2			3.30			0.130
a3	0		0.10	0		0.004
b	0.22		0.38	0.008		0.015
c	0.23		0.32	0.009		0.012
D (1)	15.80		16.00	0.622		0.630
D1	9.40		9.80	0.370		0.385
E	13.90		14.50	0.547		0.570
E1 (1)	10.90		11.10	0.429		0.437
E2			2.90			0.114
E3	5.80		6.20	0.228		0.244
e		0.65			0.0256	
e3		11.05			0.435	
G	0		0.10	0		0.004
H	15.50		15.90	0.610		0.626
h			1.10			0.043
L	0.80		1.10	0.031		0.043
N	10° (max)					
S	8° (max)					

1. "D" and "E1" do not include mold flash or protusions
 - Mold flash or protusions shall non exceed 0.15mm (0.006 inch)
 - Critical dimensions are "a3", "E" and "G".

Figure 8. PowerSO-36 Scheme

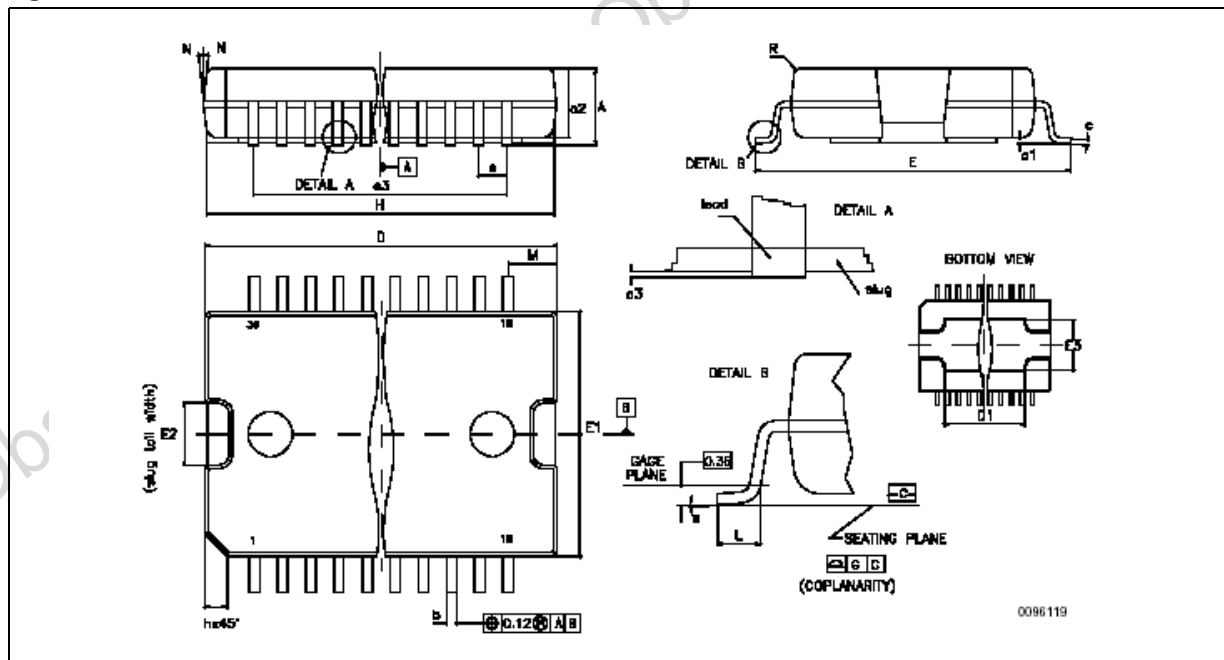

Table 11. Order Codes

Package	Tube	Tape and Reel
PowerSO-36	VN808CM	VN808CM13TR

Obsolete Product(s) - Obsolete Product(s)

Table 12. Revision History

Date	Revision	Changes
12-Sep-2005	1	First release

Obsolete Product(s) - Obsolete Product(s)

Information furnished is believed to be accurate and reliable. However, STMicroelectronics assumes no responsibility for the consequences of use of such information nor for any infringement of patents or other rights of third parties which may result from its use. No license is granted by implication or otherwise under any patent or patent rights of STMicroelectronics. Specifications mentioned in this publication are subject to change without notice. This publication supersedes and replaces all information previously supplied. STMicroelectronics products are not authorized for use as critical components in life support devices or systems without express written approval of STMicroelectronics.



The ST logo is a registered trademark of STMicroelectronics.
All other names are the property of their respective owners

© 2005 STMicroelectronics - All rights reserved

STMicroelectronics group of companies

Australia - Belgium - Brazil - Canada - China - Czech Republic - Finland - France - Germany - Hong Kong - India - Israel - Italy - Japan -
Malaysia - Malta - Morocco - Singapore - Spain - Sweden - Switzerland - United Kingdom - United States of America

www.st.com