

**PLEASE CHECK WWW.MOLEX.COM FOR LATEST PART INFORMATION**

**Part Number:** **0190850005**  
**Status:** **Active**  
**Description:** Open Barrel Ring , Tin-Plated Brass, for 14-18 AWG Wire, Stud Size 8 (M4)

**Documents:**

[Drawing \(PDF\)](#) [RoHS Certificate of Compliance \(PDF\)](#)  
[Product Specification PS-19902-006 \(PDF\)](#)

**Agency Certification**

CSA LR18689  
 UL E32244

**General**

Product Family Ring and Spade Terminals  
 Series 19085  
 Crimp Quality Equipment Yes  
 Mil-Spec N/A  
 Product Name N/A  
 Type Ring

**Physical**

Barrel Type Open  
 Insulation None  
 Material - Plating Mating Tin  
 Packaging Type Reel  
 Plating min: Mating (µin) 200  
 Plating min: Mating (µm) 5  
 Plating min: Termination (µin) 200  
 Plating min: Termination (µm) 5  
 Stud Size 8 (M4)  
 Temperature Range - Operating 149°C  
 Termination Interface: Style Crimp or Compression  
 Wire Insulation Diameter N/A  
 Wire Size AWG 14, 16, 18  
 Wire Size mm<sup>2</sup> 0.80 - 2.00

**Electrical**

Voltage - Maximum 2000V

**Material Info**

Old Part Number RZ-4129-08

**Reference - Drawing Numbers**

Product Specification PS-19902-006  
 Sales Drawing SD-19085-002

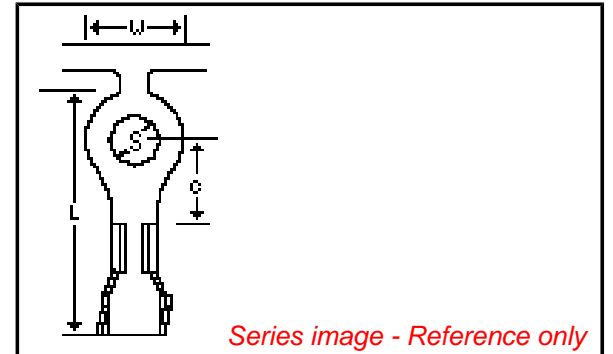

**EU RoHS**

**ELV and RoHS Compliant**  
**REACH SVHC**  
 Not Reviewed  
**Halogen-Free Status**  
**Not Reviewed**

**China RoHS**



**Need more information on product environmental compliance?**

Email [productcompliance@molex.com](mailto:productcompliance@molex.com)  
 For a multiple part number RoHS Certificate of Compliance, [click here](#)

Please visit the [Contact Us](#) section for any non-product compliance questions.

**Search Parts in this Series**

19085Series

**Application Tooling | [FAQ](#)**

*Tooling specifications and manuals are found by selecting the products below. Crimp Height Specifications are then contained in the Application Tooling Specification document.*

**Global**

Description	Product #
ASP Perishable Tool Kit used in ASP presses that process metal strip product	<u>0190290053</u>
Mini-Mac™ Applicator	<u>0638815600</u>

MATERIAL NUMBER	ENGINEERING NUMBER	STUD SIZE "S" ±.010/.(0.25)	MATERIAL	PLATING
190850001	19085-0001	#6 = .146/(3.71)	BRASS	NONE
190850002	19085-0002	#8 = .173/(4.39)	BRASS	NONE
190850003	19085-0003	#10 = .198/(5.03)	BRASS	NONE
190850004	RZ-4129-06	#6 = .146/(3.71)	BRASS	TIN
190850005	RZ-4129-08	#8 = .173/(4.39)	BRASS	TIN
190850006	RZ-4129-10	#10 = .198/(5.03)	BRASS	TIN
190850007	RZ-S-4129-06	#6 = .146/(3.71)	STEEL	TIN
190850008	RZ-S-4129-08	#8 = .173/(4.39)	STEEL	TIN
190850009	RZ-S-4129-10	#10 = .198/(5.03)	STEEL	TIN

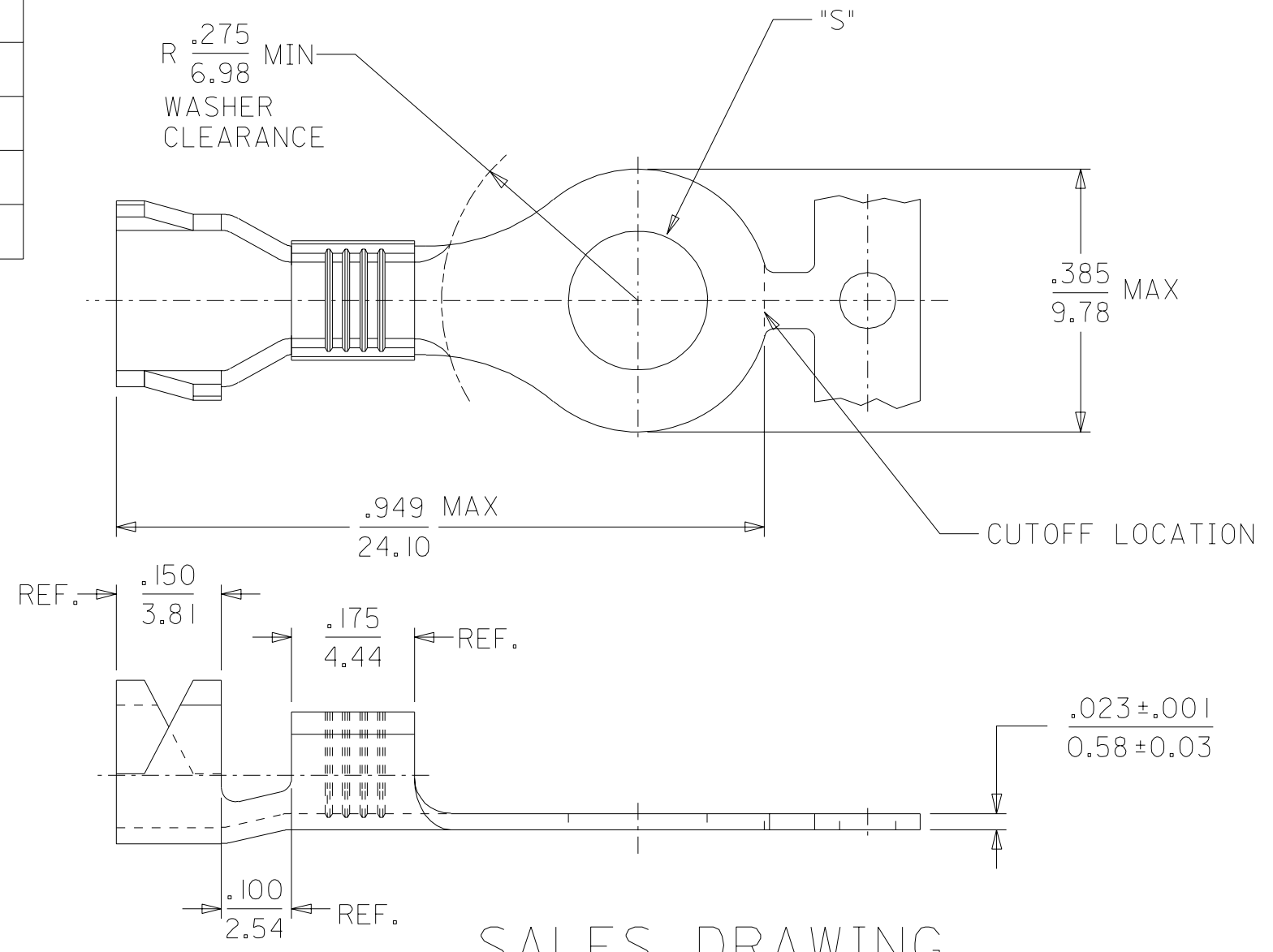

SALES DRAWING

- NOTES:
1. MATERIAL: SEE CHART.
  2. PLATING: SEE CHART.
  3. WIRE RANGE: 18-14 AWG/1.3-2.6 MM.<sup>2</sup>

WAS CD-4116 EC NO. ETC2002-0287 DRWN: BRE 02/04/10 CHK: HEB 02/04/10 APPR: RWD 02/04/10	QUALITY SYMBOLS MAJOR $\nabla = 0$ CRITICAL $\nabla C = 0$	GENERAL TOLERANCES: (UNLESS SPECIFIED)		SCALE NO: NE	DESIGN UNITS <input type="checkbox"/> mm <input checked="" type="checkbox"/> INCH	DIMENSIONS: <input type="checkbox"/> mm <input checked="" type="checkbox"/> INCH <input type="checkbox"/> mm ONLY	SHT REV
		4 PLACES $\pm 0.$ $\pm .$	3 PLACES $\pm 0.$ $\pm .$	DRAWN BY & DATE BRE 02/04/02	TITLE: VIBRAKRIMP STRIP RING TONGUE TERMINAL		
		2 PLACES $\pm 0.$ $\pm .$	1 PLACE $\pm 0.$ $\pm .$	CHECKED BY & DATE HEB 02/04/02	MOLEX INCORPORATED		
		ANGULAR: $\pm 1/2^\circ$		APPROVED BY & DATE RWD 02/04/02	CAD FILENAME SD-19085-002 .DGN	MATERIAL NO. SEE CHART	DRAWING NO. SD-19085-002
DRAFT WHERE APPLICABLE MUST REMAIN WITHIN DIMENSIONS		THIS DRAWING CONTAINS INFORMATION THAT IS PROPRIETARY TO MOLEX INCORPORATED AND SHOULD NOT BE USED WITHOUT WRITTEN PERMISSION.					SIZE B