



## F2967

Preliminary

**LINEAR INTEGRATED CIRCUIT**

### FOR VARIABLE SPEED FAN MOTOR SINGLE-PHASE FULL-WAVE PRE-DRIVER

#### DESCRIPTION

The UTC **F2967** is a single-phase fan motor pre-driver IC. This IC has variable speed function that works with an external Pulse-Width Modulation signal. A quiet and low power consumption motor driver circuit can be implemented by adding a small number of external components.

This IC is optimal for driving large scale fan motors (with large air volume and large current) such as those used in servers and consumer products.

#### FEATURES

- \* Single-phase full-wave drive
- \* Variable speed control with External PWM input
- \* Current limiter circuit
- \* Reactive current cut circuit
- \* Compatible with 12V, 24V, and 48V power supplies
- \* Minimum speed setting pin
- \* Reference voltage output pin for Hall bias
- \* automatic reset and Lock protection functions incorporated
- \* (Rotation speed detection), RD (Lock detection) output

#### ORDERING INFORMATION

Ordering Number		Package	Packing
Lead Free	Halogen Free		
F2967L-P20-T	F2967G-P20-T	TSSOP-20	Tube
F2967L-P20-R	F2967G-P20-R	TSSOP-20	Tape Reel

<p>F2967L-P20-T</p>	<p>(1) Packing Type (1) T: Tube, R: Tape Reel</p> <p>(2) Package Type (2) P20: TSSOP-20</p> <p>(3) Lead Free (3) L: Lead Free, G: Halogen Free</p>
---------------------	--

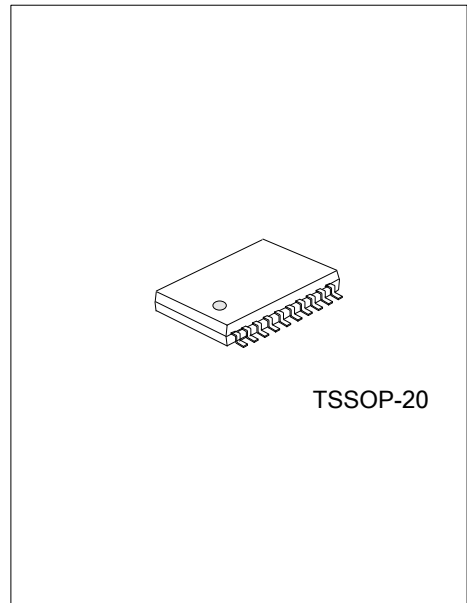

■ PIN CONFIGURATION

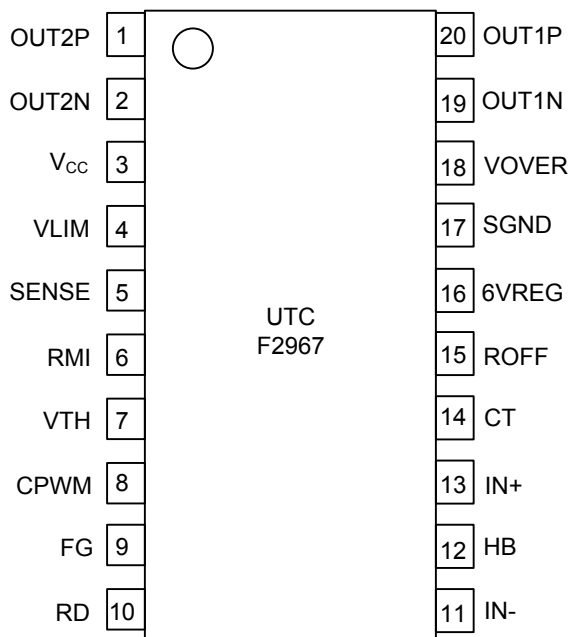

■ PIN DESCRIPTION

PIN NO.	PIN NAME	DESCRIPTION
1	OUT2P	Output2P
2	OUT2N	Output2N
3	VCC	Power supply
4	VLIM	Setting limit current pin
5	SENSE	Sense pin of current limiter
6	RMI	Lowest speed setting voltage
7	VTH	Variable speed function input
8	CPWM	PWM oscillator frequency setting capacitor
9	FG	Speed detection output
10	RD	lock detection output
11	IN-	The hall sensor input
12	HB	Power the hall sensor 1.25V
13	IN+	The hall sensor input
14	CT	Setting lock protection time
15	ROFF	The pin sets soft switching time
16	6VREG	VREF 6V
17	SGND	Logic GND
18	VOVER	The pin for constant VCC voltage
19	OUT1N	Output2P
20	OUT1P	Output2N

■ BLOCK DIAGRAM

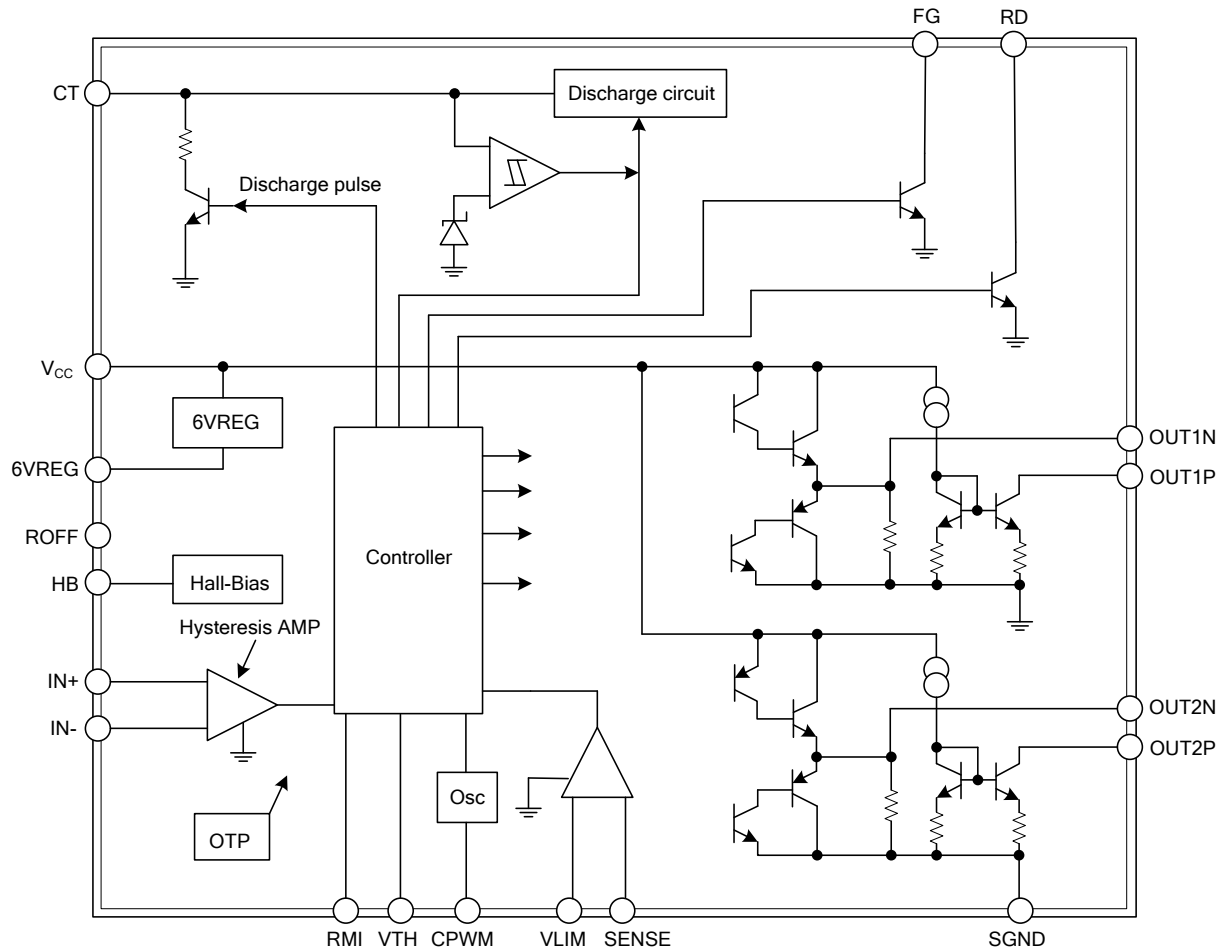

■ ABSOLUTE MAXIMUM RATING (T<sub>A</sub>=25°C)

PARAMETER		SYMBOL	RATINGS	UNIT
Maximum Supply Voltage V <sub>CC</sub>		V <sub>CC max</sub>	18	V
Maximum Output Current		I <sub>OUT max</sub>	50	mA
Output Withstand Voltage		V <sub>OUT max</sub>	18	V
HB Maximum Output Current		HB	10	mA
VTH Input Pin Withstand Voltage		V <sub>TH max</sub>	8	V
RD/FG Output Pin Output Withstand Voltage		F <sub>G max</sub>	18	V
RD/FG Output Current		F <sub>G max</sub>	10	mA
Allowable Power Dissipation	Mounted on a specified board (Note 2)	P <sub>d max</sub>	800	mW
Operating Temperature		T <sub>OPR</sub>	-30~+95	°C
Storage Temperature		T <sub>STG</sub>	-55~+150	°C

Notes: 1. Absolute maximum ratings are those values beyond which the device could be permanently damaged.

Absolute maximum ratings are stress ratings only and functional device operation is not implied.

2. Mounted on a specified board (114.3mm×76.1mm×1.6mm, Glass epoxy)

■ RECOMMENDED OPERATING RANGE (T<sub>A</sub>=25°C)

PARAMETER		SYMBOL	RATINGS	UNIT
V <sub>CC</sub> Supply Voltage		V <sub>CC</sub>	6~16	V
VTH Input Level Voltage Range	Full Speed Mode	V <sub>TH</sub>	0~7	V
Hall Input Common Phase Input Voltage Range		V <sub>ICM</sub>	0.2~3	V

■ ELECTRICAL CHARACTERISTICS (T<sub>A</sub>=25°C, V<sub>CC</sub>=12V, unless otherwise specified)

PARAMETER	SYMBOL	TEST CONDITIONS	MIN	TYP	MAX	UNIT
Circuit Current	I <sub>CC1</sub>	During Drive	6	10	14	mA
	I <sub>CC2</sub>	During Lock Protection	6	10	14	mA
6VREG Voltage	6V <sub>REG</sub>	I <sub>6VREG</sub> =5mA	5.80	6.0	6.15	V
VOVER Voltage	V <sub>OVER</sub>		12.0	12.8	13.6	V
CPWM-H Voltage	V <sub>CRH</sub>		4.35	4.55	4.75	V
CPWM-L Voltage	V <sub>CRL</sub>		1.45	1.65	1.85	V
CPWM Oscillation Frequency	F <sub>PWM</sub>	C=100pF	18	25	32	kHz
CT Pin H Voltage	V <sub>CTH</sub>		3.4	3.6	3.8	V
CT Pin L Voltage	V <sub>CTL</sub>		1.4	1.6	1.8	V
ICT Pin Charge Current	I <sub>CT1</sub>		1.6	2.0	2.5	μA
ICT Pin Discharge Current	I <sub>CT2</sub>		0.16	0.20	0.28	μA
ICT Charge/Discharge Current Ratio	R <sub>CT</sub>		8	10	12	deg
OUT-N Output Voltage	V <sub>ON</sub>	I <sub>O</sub> =20mA	4	10		V
OUT-P Sink Current	I <sub>OP</sub>		15	20		mA
Sensitivity of Hall Input	V <sub>HN</sub>	Zero Peak Value (Including Offset and Hysteresis)		10	20	mV
RD/FG Output Pin L Voltage	V <sub>FG</sub>	I <sub>FG</sub> =5mA		0.15	0.3	V
RD/FG Output Pin Leak Current	I <sub>FGL</sub>	V <sub>FG</sub> =16V			30	μA

■ TRUTH TABLE

During full-speed rotation

IN-	IN+	CT	OUT1P	OUT1N	OUT2P	OUT2N	FG	RD	Mode
H	L	L	L	-	-	H	L	L	OUT1→2 drive
L	H	-	-	H	L	-	OFF	-	OUT2→1 drive
H	L	H	OFF	-	-	H	L	OFF	Lock Protection
L	H		-	H	OFF	-	OFF	-	-

VTH	CPWM	IN-	IN+	OUT1P	OUT1N	OUT2P	OUT2N	Mode
L	H	H	L	L	-	-	H	OUT1→2 drive
		L	H	-	H	L	-	OUT2→1 drive
H	L	H	L	OFF	-	-	H	During Rotation Regeneration in Lower TR
		L	H	-	H	OFF	-	

## ■ CONTROL TIMING CHART

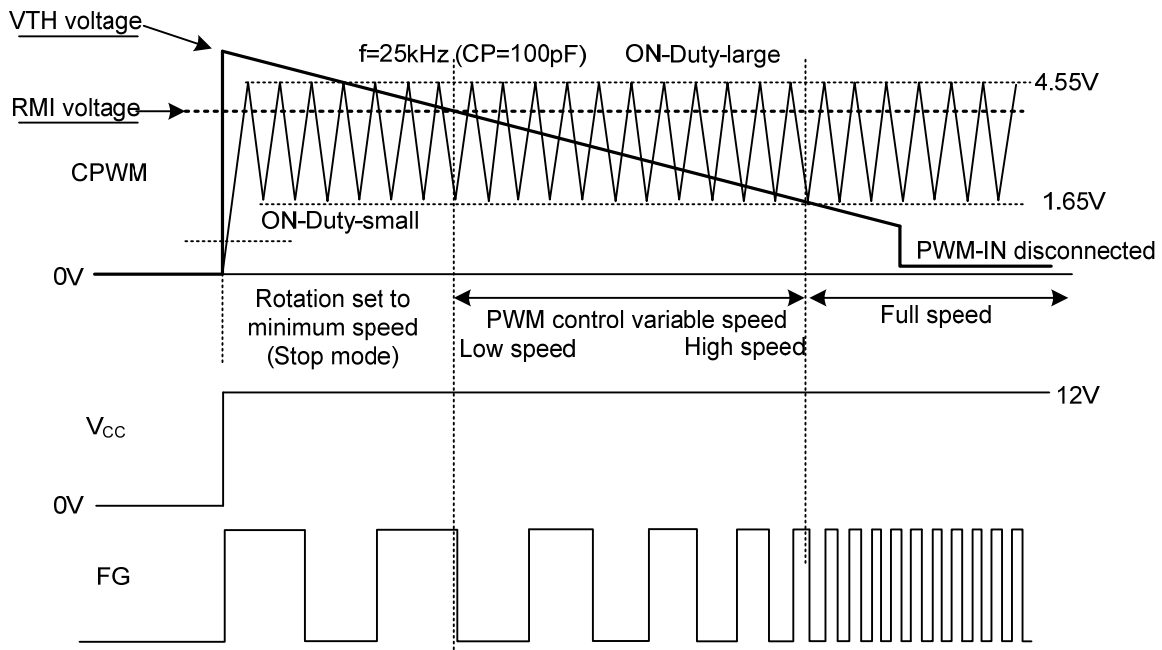

### (1) Minimum speed setting (stop) mode

Input of PWM-IN is filtered to generate the VTH voltage. At low speed, the fan rotates with the minimum speed set with RMI pin during low speed. If the minimum speed is not set (RMI=6VREG), the fan stops.

### (2) Low ⇔ High speed mode

PWM control is made through comparison of oscillation and VTH voltages with CPWM changing between 1.6V ⇔ 4.6V.

When the VTH voltage is lower, the IC switches to drive mode. When the VTH voltage is higher, the p-channel FET is turned off and coil current is regenerated through the low-side FET. Therefore, as the VTH voltage lowers, the output ON-DUTY increases, increasing the coil current and raising the motor speed.

The rotation speed is fed back by the FG output.

### (3) Full speed mode

The full-speed mode becomes effective with the VTH voltage of 1.65V or less. (VTH must be equal to GND when the speed control is not to be made.)

### (4) PWM-IN input disconnection mode

While the input pin of PWM-IN is disconnected, VTH becomes 1.65V or less and the output enables full drive at 100%. The fan runs at full speed. (Refer to the sample application circuit.)

■ TYPICAL APPLICATION CIRCUIT

12V Sample Application Circuit

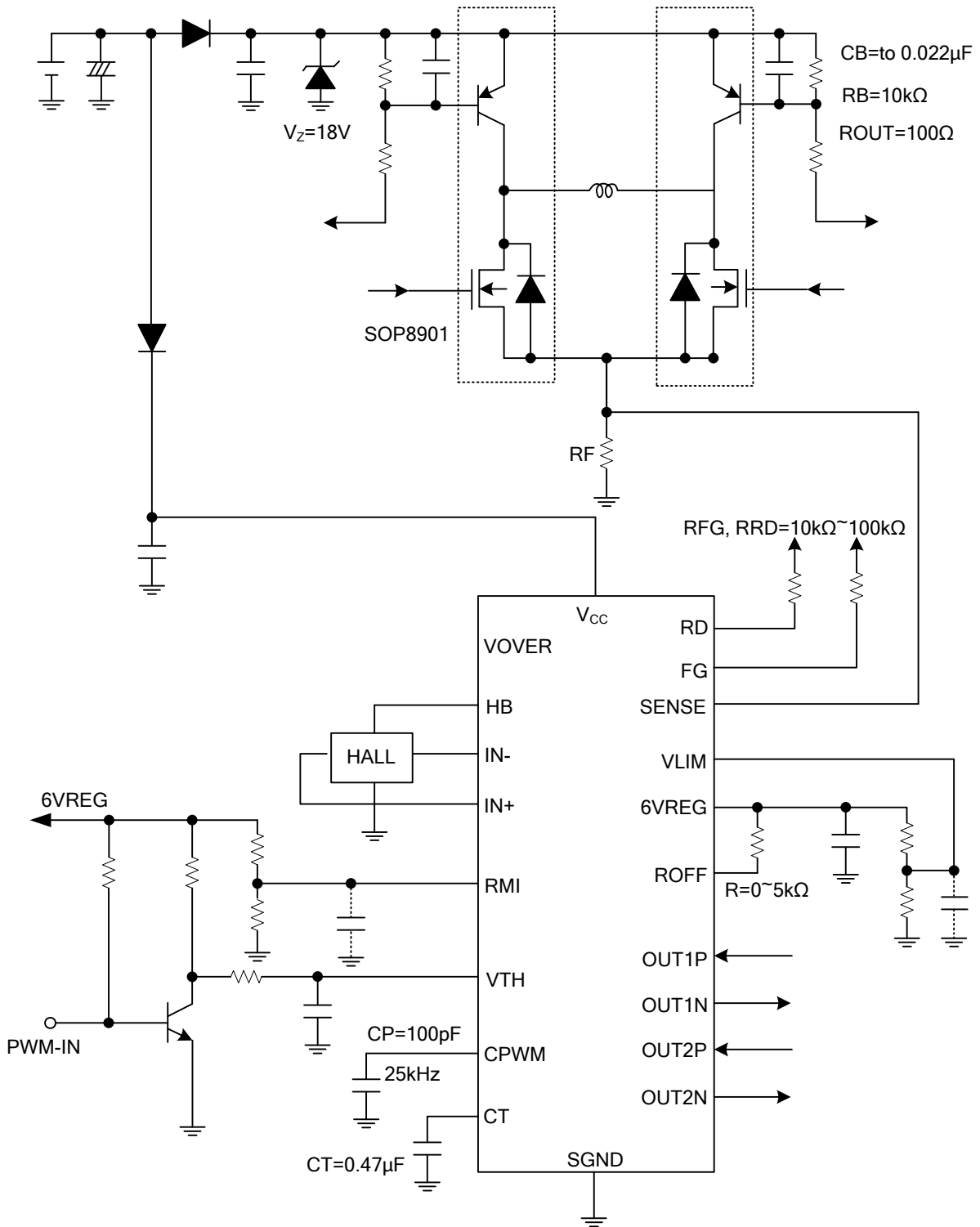

■ TYPICAL APPLICATION CIRCUIT(Cont.)

24V, 48V Sample Application Circuit

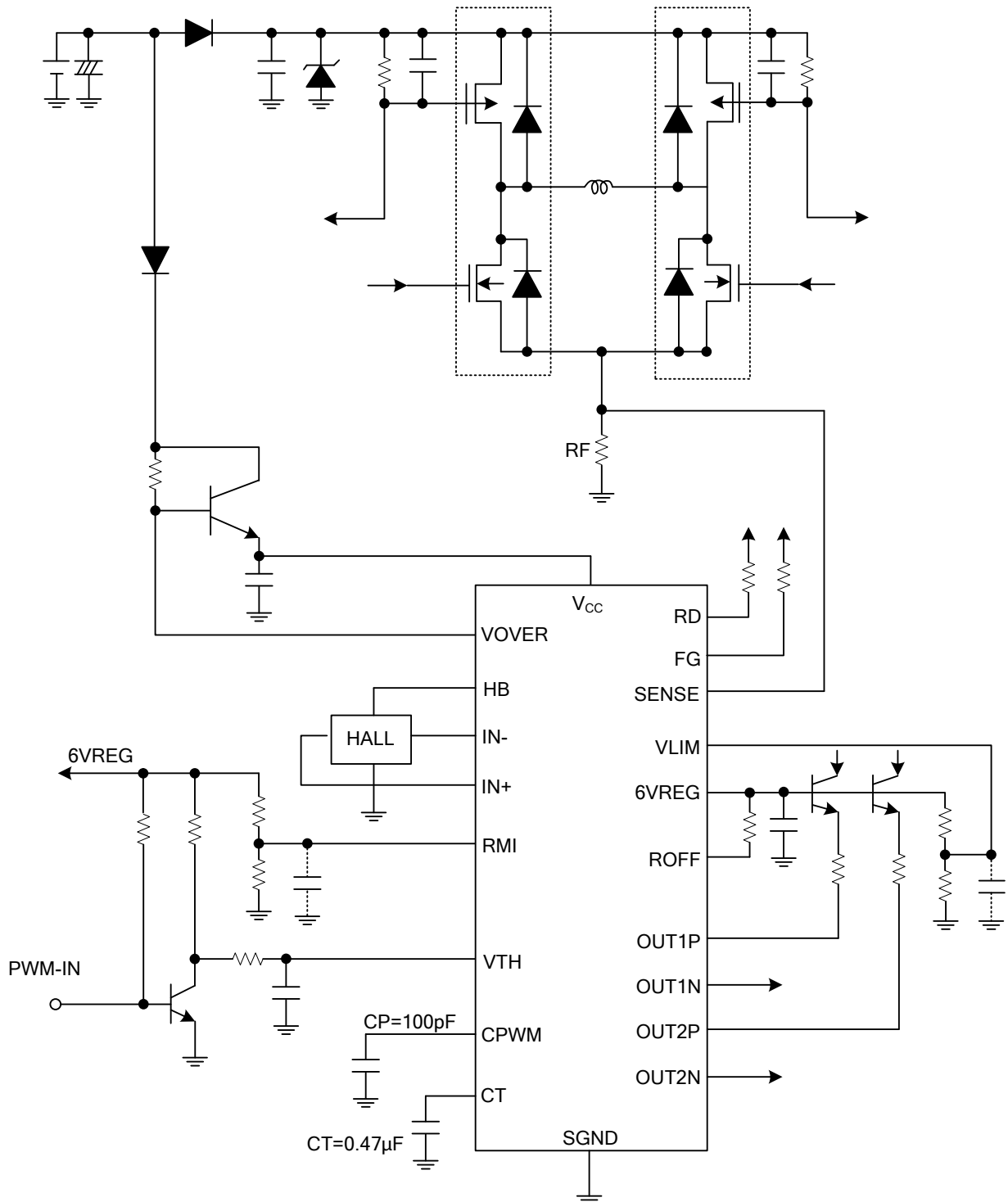



UTC assumes no responsibility for equipment failures that result from using products at values that exceed, even momentarily, rated values (such as maximum ratings, operating condition ranges, or other parameters) listed in products specifications of any and all UTC products described or contained herein. UTC products are not designed for use in life support appliances, devices or systems where malfunction of these products can be reasonably expected to result in personal injury. Reproduction in whole or in part is prohibited without the prior written consent of the copyright owner. The information presented in this document does not form part of any quotation or contract, is believed to be accurate and reliable and may be changed without notice.