

Multi-mode (WCDMA B2 / CDMA BC1 / HSPA+ / LTE) 3x3mm PA Module

Functional Block Diagram

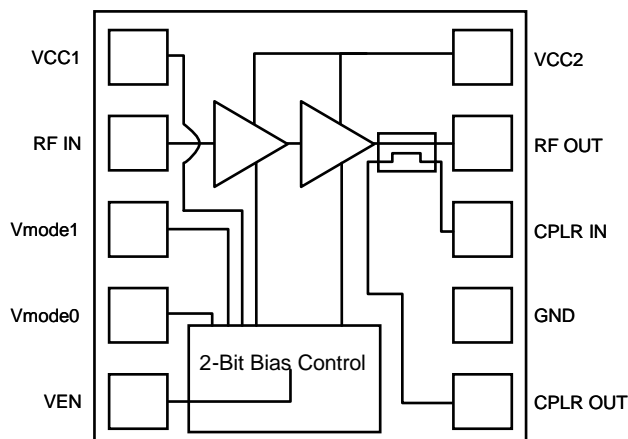

Product Description

The TQM766012 is fully matched Power Amplifier Module designed for use in WCDMA UMTS Band 2, CDMA BC1 (PCS) & LTE handsets. Its compact 3x3mm package including a coupler and built-in voltage regulator makes it ideal for today's extremely small data enabled phones. Its RF performance meets the stringent linearity requirements for multi-mode operation.

The TQM766012 is designed on TriQuint's GaAs BiHEMT technology with CuFlip® assembly offering state of the art reliability, temperature stability and ruggedness. The 3-Gain state PA die operates in LPM, MPM and HPM to maximize talk time over the entire range of operating conditions. To simplify the cost/time of calibration while in production the TQM766012 can be used in 1-bit operation; either LPM/HPM with only 4mA of IcQ up to +13dBm in LPM, or MPM/HPM with 9mA of IcQ up to +17dBm in MPM.

Electrical Specifications

Parameter	Typ	Units
Frequency	1880	MHz
WCDMA mode maximum Pout ¹	28.6	dBm
LPM Quiescent Current	4	mA
ACLR5	-41	dBc
ACLR10	-55	dBc
Power Supply Current @ 28.6dBm	500	mA
Rx Band Noise	-137	dBm/Hz

Note 1: Test Conditions WCDMA REL99 Test Mode: Vcc=3.4VDC, Ven=HIGH, Tc=25°C

Features

- GaAs BiHEMT / CuFlip® PA Technology
- Typical Quiescent Current values:
LPM: 4 mA
MPM: 9 mA
HPM: 90 mA
- Excellent Linearity in all modes
- Excellent Phase discontinuity
- Integrated high performance coupler
- Built-in voltage regulator functionality eliminating any external switch circuitry
- Small 10-pin, 3x3mm module
- Lead-free 260°C / RoHS / Halogen-free
- Full ESD protection

Applications

- WCDMA B2 Applications
- CDMA2000 BC1 (PCS) Applications
- HSDPA/HSUPA/HSPA+ Applications
- LTE-Compatible Applications

Package Style

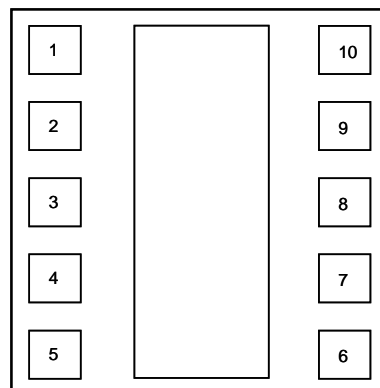

10-Pin Laminate Module
Top View (through package)

Data Sheet

For additional information and latest specifications, see our website: www.triquint.com
Revision L, August 08, 2012

