

DIAMOND

Fiber Optic Components

E-2000™

E-2916.6

E-2956.6

CRIMP&CLEAVE

The E-2000™ Crimp&Cleave System is designed for field termination of 200/230 µm HCS-Fiber.

All of the features, users have come to expect from the E-2000 family, are available from the E-2000™ Crimp&Cleave, including: ease of installation, integrated protection caps, color coding, mechanical keying and excellent vibration resistance.

Highlights

- Injection molded housing (UL 94 V0 flammability rating)
- Positive latching mechanism
- Spring-loaded shutters
- Integrated protective caps
- Interchangeable color-coded and mechanically keyed thumb-latches and frames
- Compact, rectangular footprint; push-pull design
- High modular connector-system

• Benefits

- Rugged, cost-saving construction.
- Connector housing totally encloses ferrule to optimally protect it from dust, contaminants and scratches.
- Superior retention under axial loads.
- Engage automatically to protect personnel from eye-damaging laser radiation.
- Angled, anti-reflection surface ensures low reflectance in unmated state.
- Automatically protect personnel from eye-damaging laser radiation.
- Close automatically upon extraction to protect ferrule from dust and scratches.
- Permit clear and unmistakable identification of lines on crowded patch panels.
- Guard against improper connections.
- Permits dense packing.
- Single channel components can be upgraded to duplex through the use of a simple clip-bridge and an extended thumb-latch.

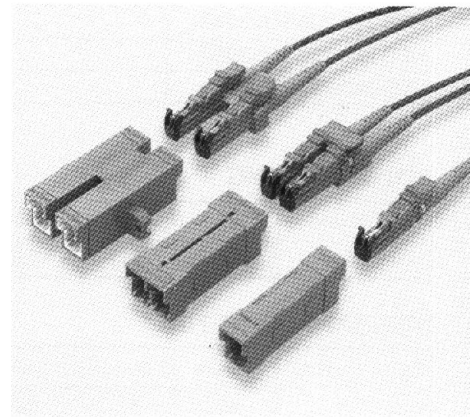

Specifications

Insertion loss	0,8 dB typ.
Service life	1000 mate/demate cycles
Operating temperature	-40/+85°C*
Storage temperature	-40/+90°C

* May be further limited by cable specifications

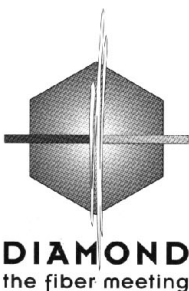

DIAMOND SA
Via dei Patrizi 5
CH-6616 LOSONE
Tel. ++41-91/785 45 45
Fax ++41-91/785 45 00
e-mail: info@diamond-fo.com

Specifications subject to change
without notice

002-037-210P005100

Order Numbers:

E-2000™ C&C SINGLE CHANNEL

Type designation: **E-2916.6**
 Ferrule style: **Zirconia/copper-nickel alloy insert (Pilzferrule)**
 External parts: **Plastic black**
 Polish geometry: **Convex (PC)**

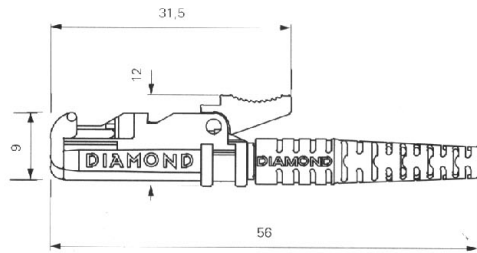

Fiber/Cable type	Order Number
HCS 200/230/900	- 002 - 001 L 000
HCS 200/230/900/2100	- 002 - 002 L 000
HCS 200/230/900/2500	- 002 - 003 L 000
HCS 200/230/900/3000	- 002 - 004 L 000
HCS 200/230/900/3500	- 002 - 005 L 000



COLOR CODING

Thumb-latch	black	blue	green	red	orange	yellow	white	violet
Order No.	301	311	321	331	341	351	361	371

MECHANICAL KEYING

Thumb-latch No.	1 (red)	2 (brown)	3 (yellow)	4 (orange)	5 (violet)	6 (white)	—	—
Order No.	401	411	421	431	441	451	—	—

ADAPTER

Type designation: **E-2201.2-333 Single Chanel**
 Mating sleeve: **Zirconia**
 External parts: **Plastic black**

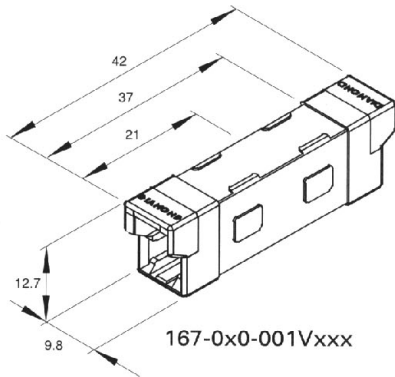

167-0x0-001Vxxx

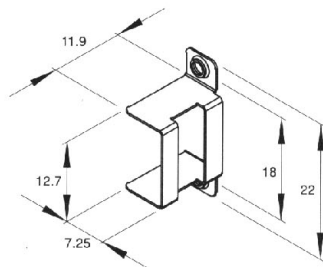

070-133-011V001

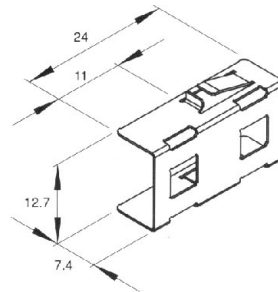

070-133-010V001

MOUNTING INSTRUCTIONS

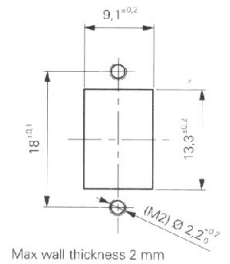

Max wall thickness 2 mm

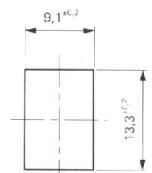

Max wall thickness 1,8 mm

COLOR CODING

Frame color	Order Number	Frame color	Order Number
Blue	167 - 00x - 001 V 301	Orange	167 - 00x - 001 V 305
Green	167 - 00x - 001 V 302	Yellow	167 - 00x - 001 V 306
Black	167 - 00x - 001 V 303	White	167 - 00x - 001 V 307
Red	167 - 00x - 001 V 304	Violet	167 - 00x - 001 V 308

MECHANICAL KEYING

Frame No.	Order Number	Frame No.	Order Number
1 (Red)	167 - 00x - 101 V 300	4 (Orange)	167 - 00x - 401 V 300
2 (Brown)	167 - 00x - 201 V 300	5 (Violet)	167 - 00x - 501 V 300
3 (Yellow)	167 - 00x - 301 V 300	6 (White)	167 - 00x - 601 V 300

Order Number Codes for Mating Adapters

- ¹ Code for fixation type
 - 0 for basic body - 1 for assembled screw fixing clip - 2 for assembled quick fixing clip
- ² Code for mechanical keying
- ³ Code for color coding

Other fixations or colors upon request.

E-2000™ C&C COMPACT

Type designation: **E-2956.6**
 Ferrule material: Zirconia/copper-nickel alloy insert (Pilzferrule)
 External parts: Plastic black
 Polish geometry: Convex (PC)

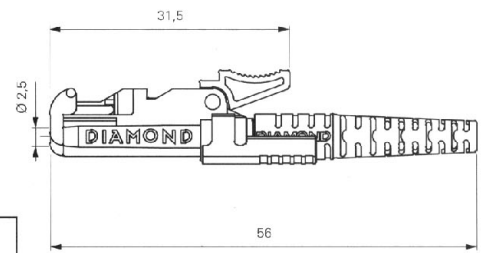

Fiber/Cable type	Order Number
HCS 200/230/900	- 002 - 001 L 000
HCS 200/230/900/2100	- 002 - 002 L 000
HCS 200/230/900/2500	- 002 - 003 L 000
HCS 200/230/900/3000	- 002 - 004 L 000
HCS 200/230/900/3500	- 002 - 005 L 000

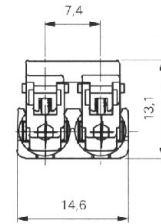

COLOR CODING

Thumb-latch	black	blue	green	red	orange	yellow	white	violet
Order No.	501	511	521	531	541	551	561	571

MECHANICAL KEYING

Thumb-latch No.	1 (red)	2 (brown)	3 (yellow)	4 (orange)	5 (violet)	6 (white)	—	—
Order No.	601	611	621	631	641	651	—	—

ADAPTER

Type designation: **E-2210.2-*** Compact**
 Mating sleeve: Zirconia
 External parts: Plastic black

MOUNTING INSTRUCTIONS

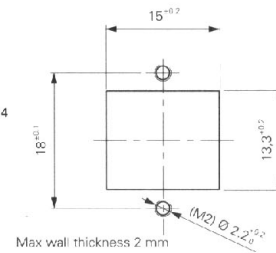
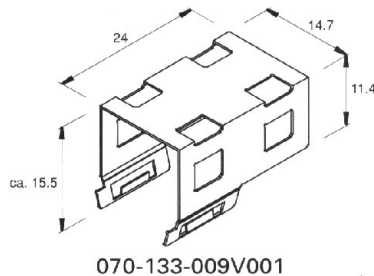
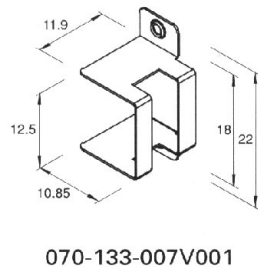
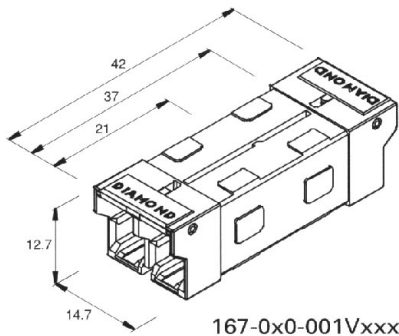

COLOR CODING

Frame color	Order Number	Frame color	Order Number
Blue	167 - 03x - 001 V 301	Orange	167 - 03x - 001 V 305
Green	167 - 03x - 001 V 302	Yellow	167 - 03x - 001 V 306
Black	167 - 03x - 001 V 303	White	167 - 03x - 001 V 307
Red	167 - 03x - 001 V 304	Violet	167 - 03x - 001 V 308

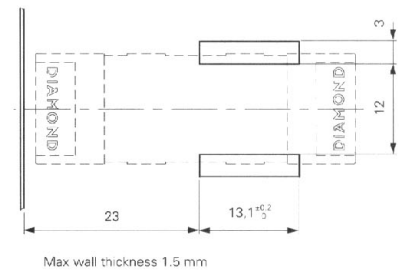

MECHANICAL KEYING

Frame No.	Order Number	Frame No.	Order Number
1 (Red)	167 - 03x - 101 V 300	4 (Orange)	167 - 03x - 401 V 300
2 (Brown)	167 - 03x - 201 V 300	5 (Violet)	167 - 03x - 501 V 300
3 (Yellow)	167 - 03x - 301 V 300	6 (White)	167 - 03x - 601 V 300

E-2000™ C&C DUPLEX

Type designation: **E-2956.6**
 Ferrule material: Zirconia/copper-nickel alloy insert (Pilzferrule)
 External parts: Plastic black
 Polish geometry: Convex (PC)

Fiber/Cable type	Order Number
HCS 200/230/900	- 002 - 001 L 000
HCS 200/230/900/2100	- 002 - 002 L 000
HCS 200/230/900/2500	- 002 - 003 L 000
HCS 200/230/900/3000	- 002 - 004 L 000
HCS 200/230/900/3500	- 002 - 005 L 000

COLOR CODING

Thumb-latch	black	blue	green	red	orange	yellow	white	violet
Order No.	304	314	324	334	344	354	364	374

ADAPTER

Type designation: **E-2210.2-333 Duplex**
 Mating sleeve: Zirconia
 External parts: Plastic black

Frame color	Order Number	Frame color	Order Number
Blue	165 - 301 - 905 V 111	Orange	165 - 301 - 905 V 155
Green	165 - 301 - 905 V 122	Yellow	165 - 301 - 905 V 166
Black	165 - 301 - 905 V 133	White	165 - 301 - 905 V 177
Red	165 - 301 - 905 V 144	Violet	165 - 301 - 905 V 188

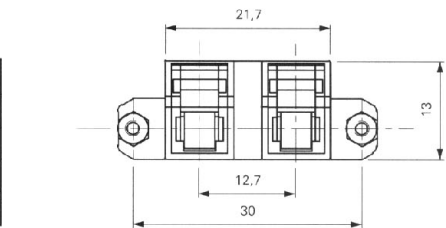
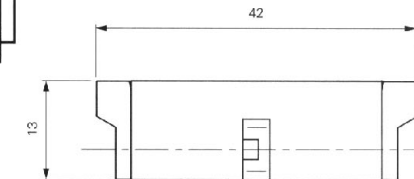
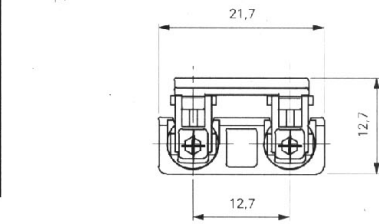
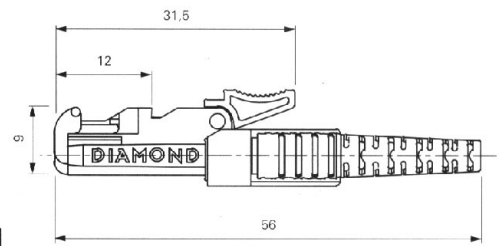

MOUNTING INSTRUCTIONS

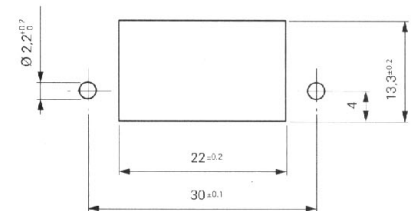

Max wall thickness 2 mm

Tools E-2000™ Crimp&Cleave

Ordering information

Termination kit

The E-2000™ Crimp&Cleave kit includes all tooling, materials, and instructions to allow the installer to quickly and fragily install connectors.

Order Numbers

Kit E-2000™ C&C complet: 241-100-044V001

Basic Kit Contents:

- | | |
|-------------------------|-----------------|
| 1 Crimp tool | 080-609-001V001 |
| 2 Scissors | 002-254-000P037 |
| 3 Diamond fiber cleaver | 000-000-000P000 |
| 4 Cable stripper | 221-100-073V001 |
| 5 Fiber stripper | 002-254-000P043 |

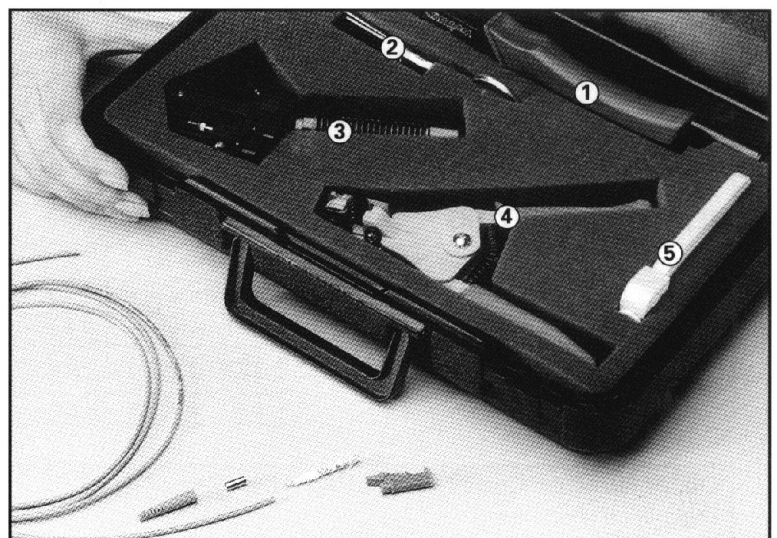

Space requirement: ca. 350 x 210 x 85 mm
 Weight ca. 1,800 Kg