

This document is intended as a reference guide for installing and using a BENDER IR420-D4 ground fault detector. This document includes installation, setup, and usage instructions. For complete details, including installation, setup, settings, and troubleshooting, refer to the IR420-D4 user manual, document number TBP101012. This document is intended as a supplement and not a replacement to the complete user manual.

Only qualified maintenance personnel shall operate or service this equipment. These instructions should not be viewed as sufficient for those who are not otherwise qualified to operate or service this equipment. This document is intended to provide accurate information only. No responsibility is assumed by BENDER for any consequences arising from use of this document.



## Installation

### Mounting

IR420-D4 series devices may be DIN rail mounted, or screw mounted using the black clips located on the top and bottom of the device. Screw mounting requires an extra black clip (article number B98060008, sold separately).

### Wiring - General

The IR420-D4 monitors a single-phase AC ungrounded system. Refer to Figure 1 for wiring diagram. Use minimum AWG 24, maximum AWG 12 size wire. Refer to IR420-D4 series user manual for complete technical details.

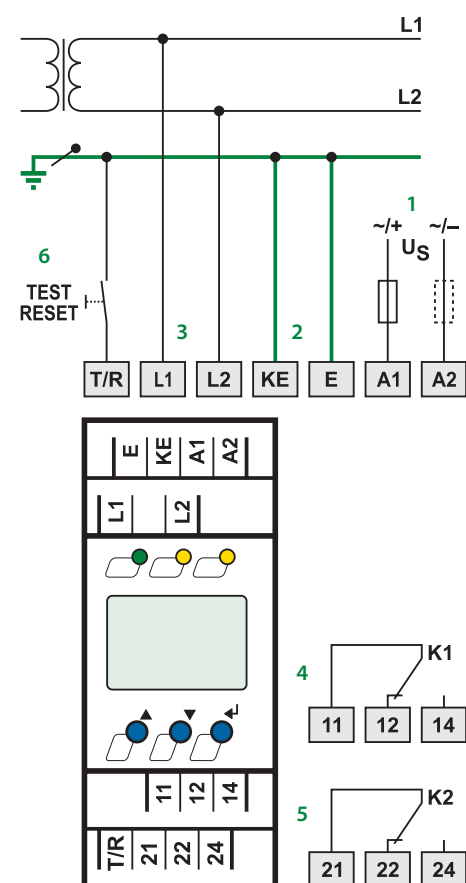

Figure 1 - IR420-D4 wiring diagram

**⚠ DANGER**

**HAZARD OF ELECTRIC SHOCK, EXPLOSION, OR ARC FLASH**

- Disconnect all power before servicing.
- Observe all local, state, and national codes, standards, and regulations.

1. External supply voltage; 5A fuse required for internal device protection (Use two fuses when powering device with ungrounded power)
2. Equipment ground connections
3. Connections to monitored system
4. Alarm relay K1: SPDT contact
5. Alarm relay K2: SPDT contact
6. Connection for optional external test/reset input

## Front Panel Display

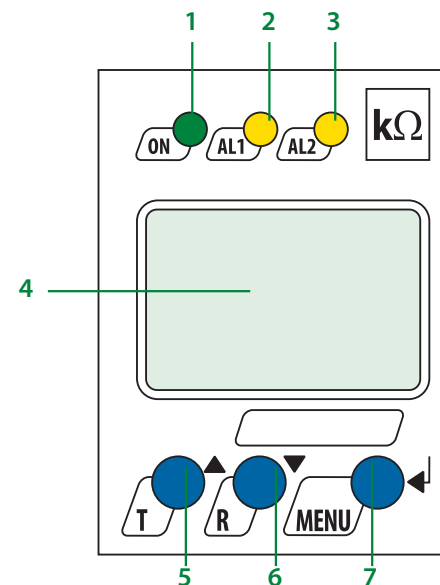
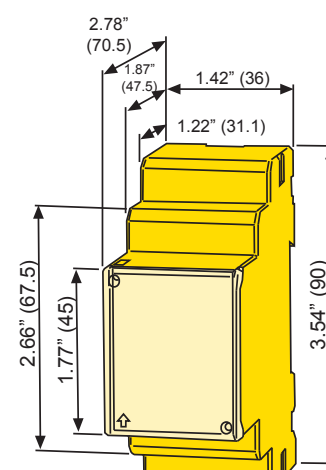

Figure 2 - IR420-D4 front display

1. LED "ON" (green): Illuminates when power is applied to the device. Flashes when the connection alarm is active.
2. LED "AL1" (yellow): Illuminates when the prealarm is activated. Flashes when the connection alarm is active.
3. LED "AL2" (yellow): Illuminates when the main alarm is activated. Flashes when CT connection alarm is active.
4. LCD display
5. TEST / UP button: Activates self-test / scrolls up inside main menu.
6. RESET / DOWN button: Resets device / scrolls down inside main menu.
7. MENU / ENTER button: Activates main menu / Confirms (momentary push) or goes back a step (held > 1.5 s) inside main menu.

## Dimensions

Dimensions in inches (mm).



### Wiring - Contacts

Using a normally closed or normally open contact utilizes two factors: wiring out of the proper terminal, and setting the respective contact to normally energized or deenergized operation. Refer to the chart below for relay conditions. For changing the energized state of the contact, refer to "Figure 6 - Contact operation" on the reverse side of this document.



The factory default for relays K1 and K2 is normally deenergized operation.

Device Relay Conditions			
Relay Operation Setting	Device Alarm State	K1 STATE	K2 STATE
Normally deenergized mode (N/D) Non-failsafe mode "N/O" in device settings menu	Power ON, normal state (no alarms)	11-12 CLOSED 11-14 OPEN	21-22 CLOSED 21-24 OPEN
	Power OFF	11-12 CLOSED 11-14 OPEN	21-22 CLOSED 21-24 OPEN
Energized in the alarm state Relay will switch when the alarm is activated.	Power ON, alarm state	11-12 OPEN 11-14 CLOSED	21-22 OPEN 21-24 CLOSED
	Power OFF	11-12 CLOSED 11-14 OPEN	21-22 CLOSED 21-24 OPEN
Normally energized mode (N/E) Failsafe mode "N/C" in device settings menu	Power ON, normal state (no alarms)	11-12 OPEN 11-14 CLOSED	21-22 OPEN 21-24 CLOSED
	Power OFF	11-12 CLOSED 11-14 OPEN	21-22 CLOSED 21-24 OPEN
Energized in the normal state Relay will switch when the alarm is activated, or when supply voltage to the device is lost.	Power ON, alarm state	11-12 CLOSED 11-14 OPEN	21-22 CLOSED 21-24 OPEN
	Power OFF	11-12 OPEN 11-14 CLOSED	21-22 OPEN 21-24 CLOSED

## Menu Flow Chart for Common Settings

Figure 4 through figure on the reverse side of this document contain flow charts for modifying commonly used features and settings in the IR420-D4's main menu. Not all available features are listed in this document. For more information, consult the IR420-D4 user manual.

## Menu Legend

-  DOWN ARROW button < 1.5 s Momentary button push
-  UP ARROW button > 1.5 s Hold button for at least 1.5 s, then release
-  MENU / ENTER button

**Figure 4 - Setting alarm trip values**

The IR420-D4 monitors for ground faults by measuring the system's insulation resistance. Alarm values are set in kΩ. R2 is the main alarm. A prealarm value (R1) may also be set to give advanced notification.

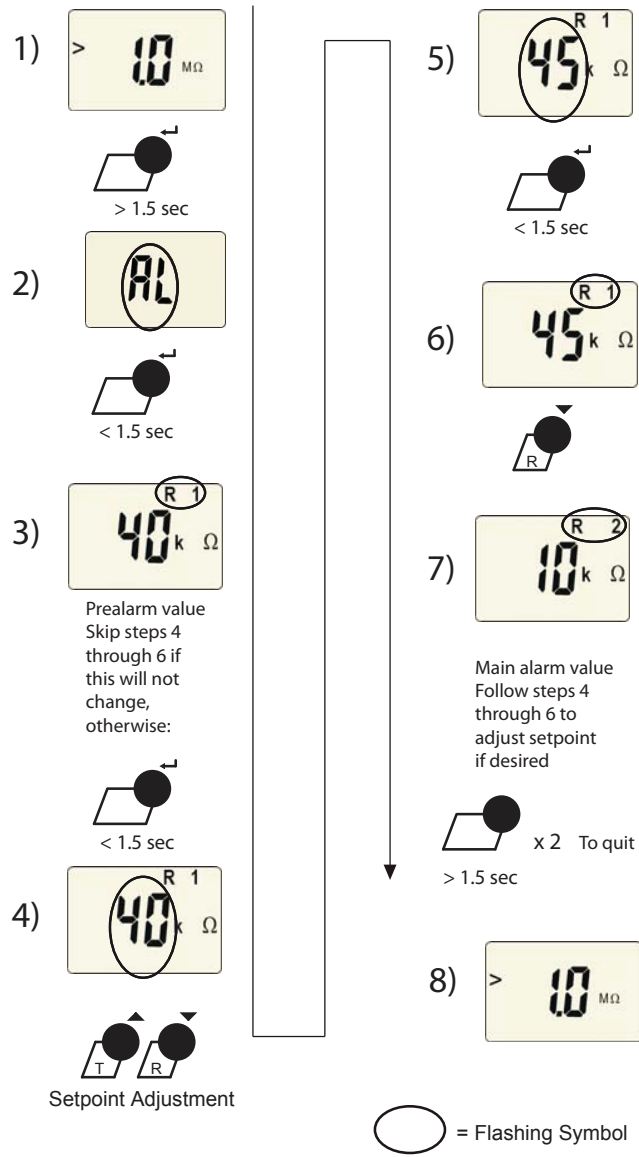

**Figure 5 - Latching behavior (fault memory)**

Changing this setting to "ON" will cause the IR420-D4 to latch in the event of an alarm, and require a manual reset if the alarm clears. Changing this setting to "OFF" will cause the IR420-D4 to automatically reset if the alarm clears.

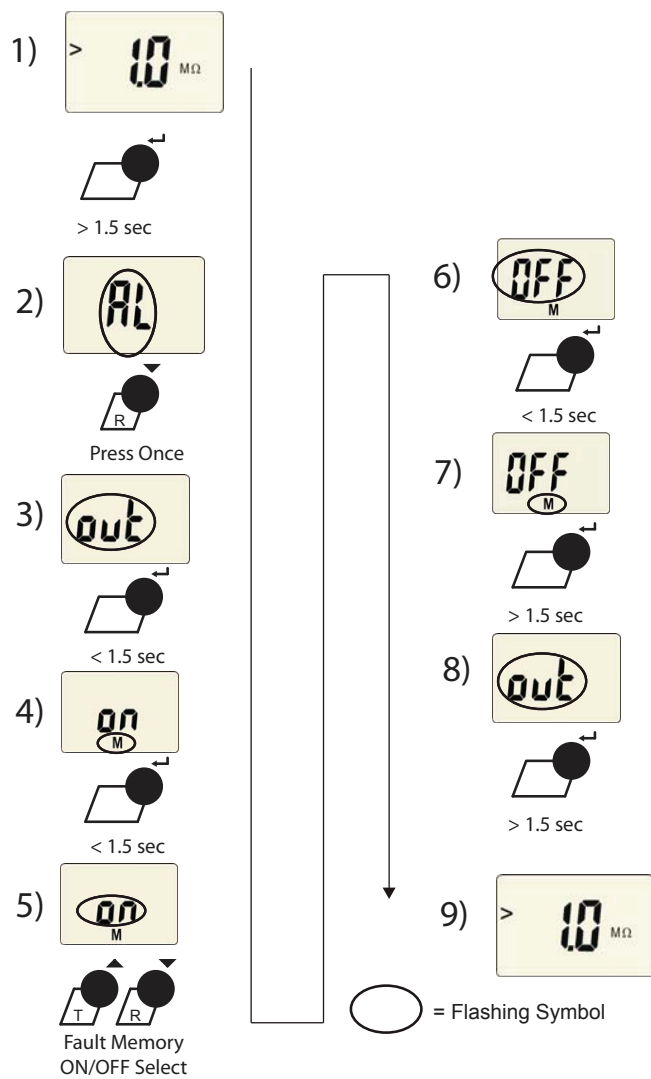

**Figure 6 - Contact operation**

Use this option to change the behavior of the contacts between normally deenergized (non-failsafe) mode and normally energized (failsafe) mode. The two SPDT contacts may be changed individually. Note that the IR420-D4 labels normally deenergized operation as "N/O" and normally energized operation as "N/C"; utilizing a normally open or normally closed contact only depends on which contact output is wired.

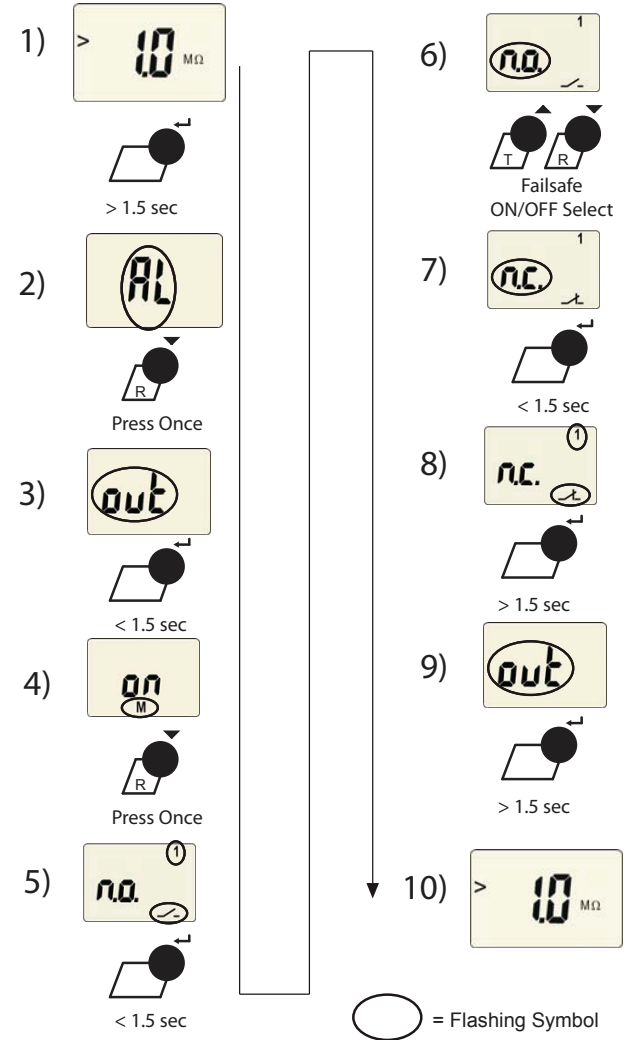

**Technical Data**

Refer to IR420-D4 series user manual (document TBP101012) or IR420-D4 series datasheet (document NAE1012090) for detailed technical information.