



# Product Specification

M150EW02 V0

AU OPTRONICS CORPORATION

( V ) Preliminary Specifications  
( ) Final Specifications

<b>Module</b>	15.0" WXGA Color TFT-LCD
<b>Model Name</b>	M150EW02 V0

<b>Customer</b>	<b>Date</b>
_____	_____
<b>Checked &amp; Approved by</b>	
_____	
<p>Note: This Specification is subject to change without notice.</p>	

<b>Approved by</b>	<b>Date</b>
_____	_____
<b>Prepared by</b>	
<i>Weiye Tseng</i>	<b>05/20/2008</b>
<p>Desktop Display Business Group / AU Optronics corporation</p>	

## Contents

<b>1. Handling Precautions .....</b>	<b>4</b>
<b>2. General Description .....</b>	<b>5</b>
2.1 Display Characteristics .....	5
2.2 Optical Characteristics .....	6
<b>3. Functional Block Diagram .....</b>	<b>10</b>
<b>4. Absolute Maximum Ratings .....</b>	<b>11</b>
4.1 Absolute Ratings of TFT LCD Module .....	11
4.2 Absolute Ratings of Backlight Unit .....	11
4.3 Absolute Ratings of Environment .....	12
<b>5. Electrical characteristics .....</b>	<b>13</b>
5.1 TFT LCD Module .....	13
5.2 Backlight Unit .....	15
<b>6. Signal Characteristic .....</b>	<b>16</b>
6.1 Pixel Format Image .....	16
6.2 The Input Data Format .....	17
6.4 Interface Timing .....	20
6.5 Power ON/OFF Sequence .....	22
<b>7. Connector &amp; Pin Assignment .....</b>	<b>23</b>
7.1 TFT LCD Module .....	23
<b>8. Reliability Test .....</b>	<b>25</b>
<b>9. Shipping Label .....</b>	<b>26</b>
<b>10. Mechanical Characteristics .....</b>	<b>27</b>



**Record of Revision**

<b>Version and Date</b>	<b>Page</b>	<b>Old description</b>	<b>New Description</b>	<b>Remark</b>
0.1 2008/05/20	All	First Edition for Customer	N/A	

FOR INTERNAL USE ONLY

[www.jxlcd.com](http://www.jxlcd.com)

## 1. Handling Precautions

- 1) Since front polarizer is easily damaged, pay attention not to scratch it.
- 2) Be sure to turn off power supply when inserting or disconnecting from input connector.
- 3) Wipe off water drop immediately. Long contact with water may cause discoloration or spot.
- 4) When the panel surface is soiled, wipe it with absorbent cotton or other soft cloth.
- 5) Since the panel is made of glass, it may break or crack if dropped or bumped on hard surface.
- 6) Since CMOS LSI is used in this module, take care of static electricity and insure human earth when handling.
- 7) Do not open or modify the Module Assembly.
- 8) Do not press the reflector sheet at the back of the module to any directions.
- 9) In case if a Module has to be put back into the packing container slot after once it was taken out from the container, do not press the center of the CCFL reflector edge. Instead, press at the far ends of the CCFL Reflector edge softly. Otherwise the TFT Module may be damaged.
- 10) At the insertion or removal of the Signal Interface Connector, be sure not to rotate nor tilt the Interface Connector of the TFT Module.
- 11) After installation of the TFT Module into an enclosure, do not twist nor bend the TFT Module even momentary. At designing the enclosure, it should be taken into consideration that no bending/twisting forces are applied to the TFT Module from outside. Otherwise the TFT Module may be damaged.
- 12) Cold cathode fluorescent lamp in LCD contains a small amount of mercury. Please follow local ordinances or regulations for disposal.
- 13) Small amount of materials having no flammability grade is used in the LCD module. The LCD module should be supplied by power complied with requirements of Limited Power Source (IEC60950 or UL1950), or be applied exemption.
- 14) The LCD module is designed so that the CCFL in it is supplied by Limited Current Circuit (IEC60950 or UL1950). Do not connect the CCFL in Hazardous Voltage Circuit.

## 2. General Description

M150EW02 V0 is a Color Active Matrix Liquid Crystal Display composed of a TFT LCD panel, a driver circuit, and backlight system.

The screen format is intended to support the WXGA (1280(H) x 720(V)) screen and 16.7M colors. All input signals are LVDS interface compatible and this module doesn't contain an inverter board for backlight.

### 2.1 Display Characteristics

The following items are characteristics summary on the table at 25 °C condition:

Items	Unit	Specifications
Screen Diagonal	[mm]	15.0"W
Active Area	[mm]	332.16 (W) x 186.84 (H)
Pixels H x V		1280x3(RGB) x 720
Pixel Pitch	[um]	259.5X259.5
Pixel Arrangement		R.G.B. Vertical Stripe
Display Mode		Normally White
White Luminance (ICCFI=7.5mA)	[cd/m <sup>2</sup> ]	250 cd/m <sup>2</sup> @ 7.5mA (Typ)
Contrast Ratio		500 (typ)
Response Time	[msec]	8 (Typ, on/off)
Nominal Input Voltage VDD	[Volt]	+3.3 typ.
Power Consumption	[Watt]	12.6W(Typ) (PDD=2.6W, PCFL=10W@Lamp=7.5mA)
Weight	[Grams]	1160(Typ)
Physical Size(H x V x D)	[mm]	354.12(W) x 210.4(H) x 12.0(D)(Typ)
Electrical Interface		one channel LVDS
Surface Treatment		Anti-Glare, Hardness 3H
Support Color		16.7M colors (RGB 6-bit + HiFRC)
RoHS Compliance		RoHS Compliance

## 2.2 Optical Characteristics

The optical characteristics are measured under stable conditions at 25°C (Room Temperature) :

Item	Unit	Conditions	Min.	Typ.	Max.	Note
Viewing Angle	[degree]	Horizontal (Right) CR = 10 (Left)	35 35	45 45	- -	1
		Vertical (Up) CR = 10 (Down)	10 30	20 40	- -	
		Horizontal (Right) CR = 5 (Left)	45 45	55 55	- -	
		Vertical (Up) CR = 5 (Down)	20 40	30 50	- -	
Luminance Uniformity	[%]	9 Points	70%	80%		2,3
Response Time	[msec]	Rising	-	6	9	4,6
		Falling	-	2	4	
		Rising + Falling		8	13	
Color / Chromaticity Coordinates (CIE 1931)		Red x	0.559	0.589	0.619	4
		Red y	0.307	0.337	0.367	
		Green x	0.282	0.312	0.342	
		Green y	0.522	0.552	0.582	
		Blue x	0.128	0.158	0.188	
		Blue y	0.115	0.145	0.175	
		White x	0.283	0.313	0.343	
White y	0.299	0.329	0.359			
White Luminance ICCFL=7.5 mA	[cd/m <sup>2</sup> ]		200	250	-	4
CR: Contrast Ratio			300	500	-	4
Cross talk	[%]			1.2	1.5	5
Flicker	[dB]		-		-20	7

Optical Equipment: BM-5A, BM-7, PR880, or equivalent

**Note 1:** Definition of viewing angle

Viewing angle is the measurement of contrast ratio  $\geq 10$  and  $\geq 5$ , at the screen center, over a 180° horizontal and 180° vertical range (off-normal viewing angles). The 180° viewing angle range is broken down as follows; 90° ( $\theta$ ) horizontal left and right and 90° ( $\Phi$ ) vertical, high (up) and low (down). The measurement direction is typically perpendicular to the display surface with the screen rotated about its center to develop the desired measurement viewing angle.

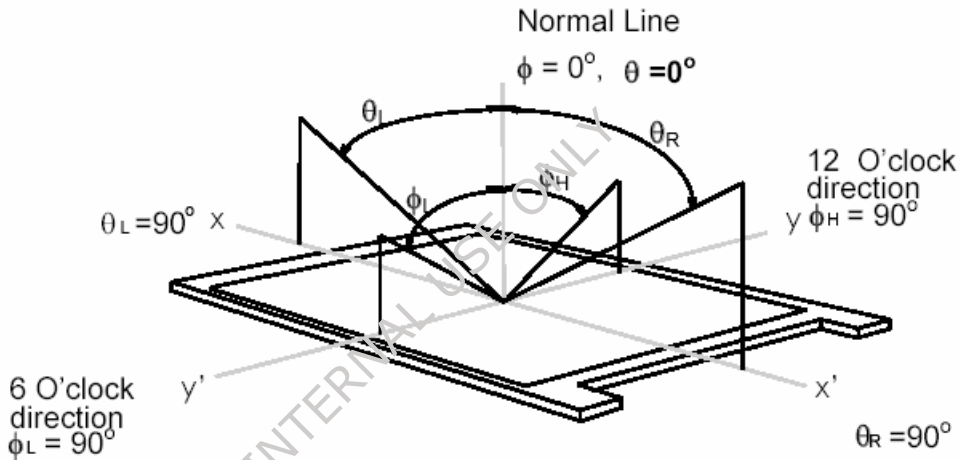

[www.jxlcd.com](http://www.jxlcd.com)

**Note 2:** 9 points position

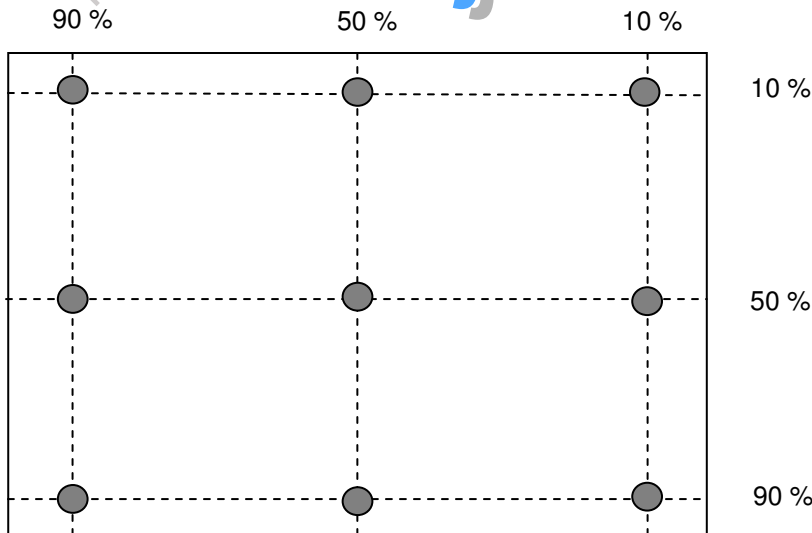

**Note 3:** The luminance uniformity of 9 points is defined by dividing the maximum luminance values by the minimum test point luminance

$$\delta_{w9} = \frac{\text{Minimum Brightness of 9 points}}{\text{Maximum Brightness of 9 points}}$$

**Note 4:** Measurement method

The LCD module should be stabilized at given temperature for 30 minutes to avoid abrupt temperature change during measuring. In order to stabilize the luminance, the measurement should be executed after lighting Backlight for 30 minutes in a stable, windless and dark room.

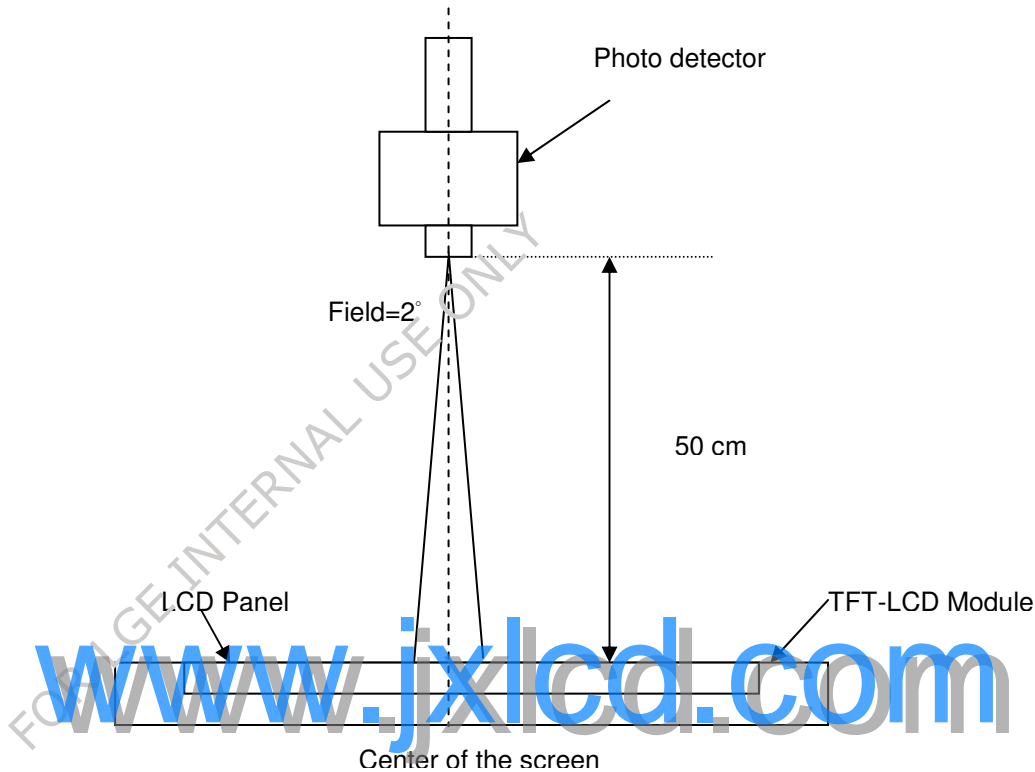

**Note 5:** Definition of Cross Talk (CT)

$$CT = | Y_B - Y_A | / Y_A \times 100 (\%)$$

Where

Y<sub>A</sub> = Luminance of measured location without gray level 0 pattern (cd/m<sup>2</sup>)

Y<sub>B</sub> = Luminance of measured location with gray level 0 pattern (cd/m<sup>2</sup>)

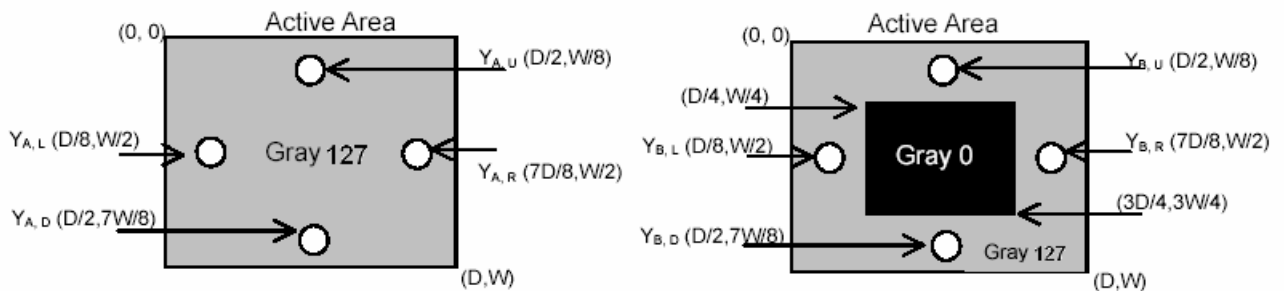



**Note 6:** Definition of response time:

The output signals of photo detector are measured when the input signals are changed from “Full Black” to “Full White” (rising time), and from “Full White” to “Full Black”(falling time), respectively. The response time is interval between the 10% and 90% of amplitudes. Please refer to the figure as below.

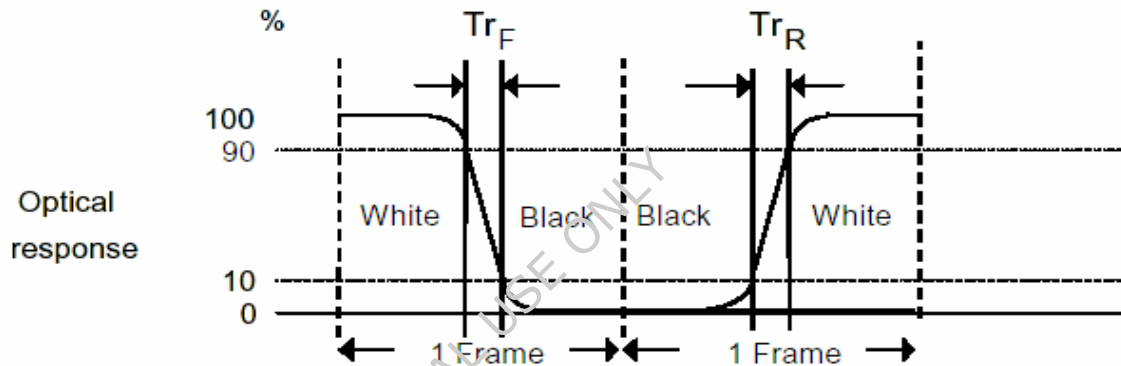

**Note 7:** Subchecker Pattern

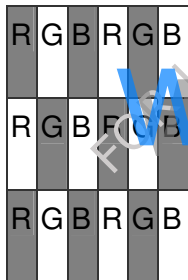

Gray Level = L127

Gray Level = L0

Method: Record dBV & DC value with (WESTAR)TRD-100

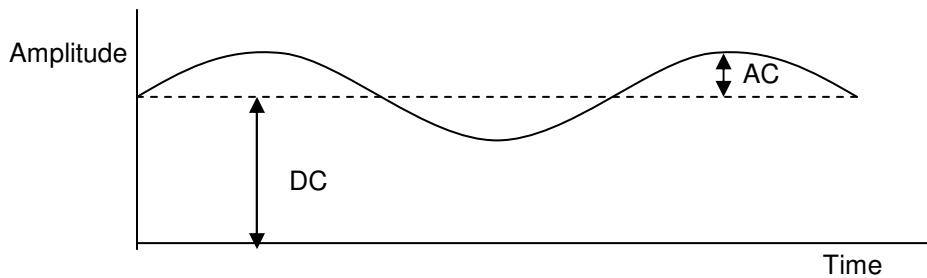

$$\text{Flicker (dB)} = 20 \log \frac{\text{AC Level (at 30 Hz)}}{\text{DC Level}}$$

## 3. Functional Block Diagram

The following diagram shows the functional block of the 15 inches wide Color TFT/LCD Module:

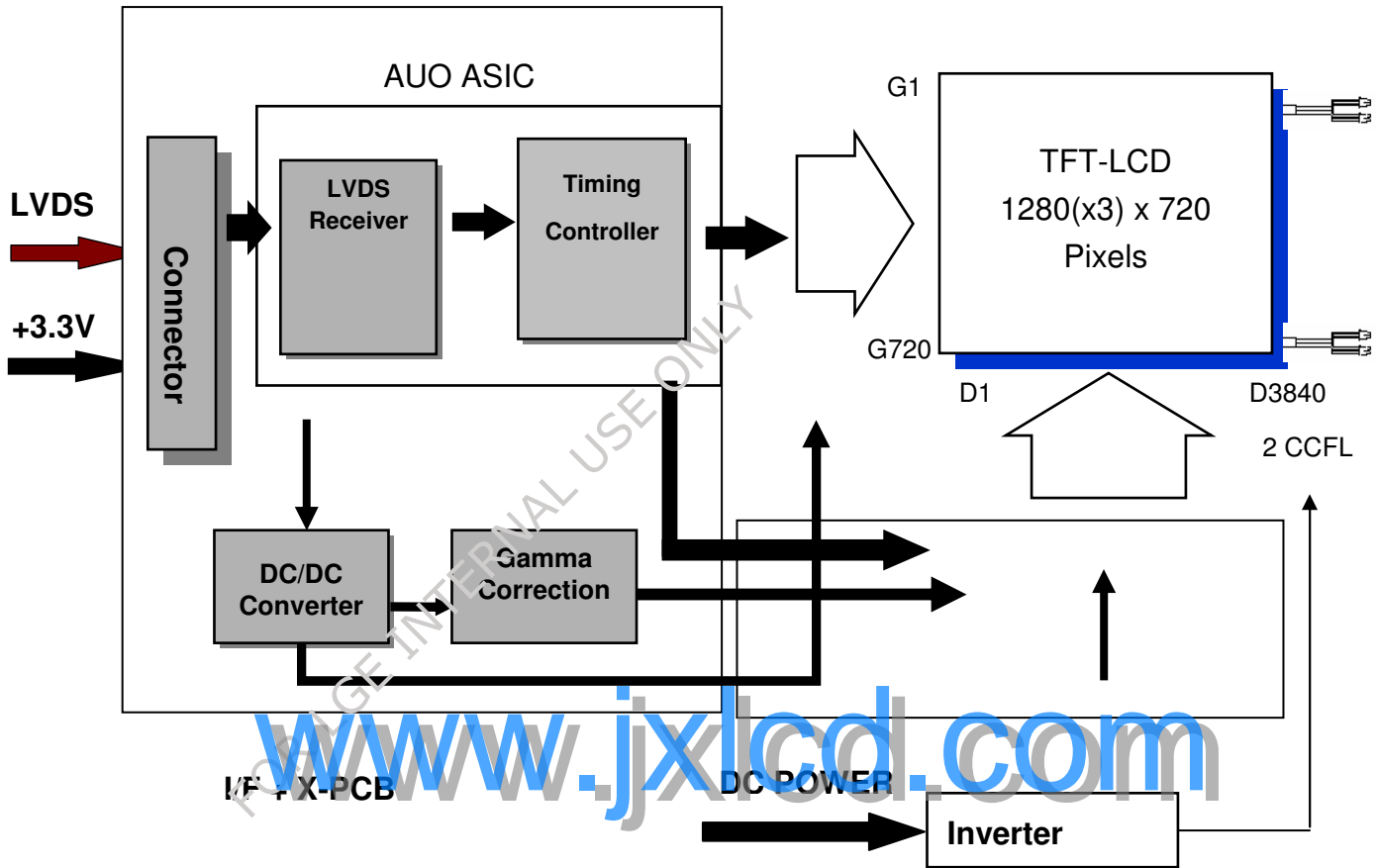



## 4. Absolute Maximum Ratings

Absolute maximum ratings of the module is as following:

### 4.1 Absolute Ratings of TFT LCD Module

Item	Symbol	Min	Max	Unit	Conditions
Logic/LCD Drive Voltage	Vin	-0.3	+3.6	[Volt]	Note 1,2

### 4.2 Absolute Ratings of Backlight Unit

Item	Symbol	Min	Max	Unit	Conditions
CCFL Current	ICCFL	-	8.0	[mA] rms	Note 1,2

FOR INTERNAL USE ONLY

[www.jxlcd.com](http://www.jxlcd.com)

## 4.3 Absolute Ratings of Environment

Item	Symbol	Min.	Max.	Unit	Conditions
Operating Temperature	TOP	0	+50	[°C]	Note 3
Operating Humidity	HOP	8	90	[%RH]	
Storage Temperature	TST	-20	+60	[°C]	
Storage Humidity	HST	8	90	[%RH]	

**Note 1:** At Ta (25°C)

**Note 2:** Permanent damage to the device may occur if exceed maximum values

**Note 3:** For quality performance, please refer to AUC IIS(Incoming Inspection Standard).

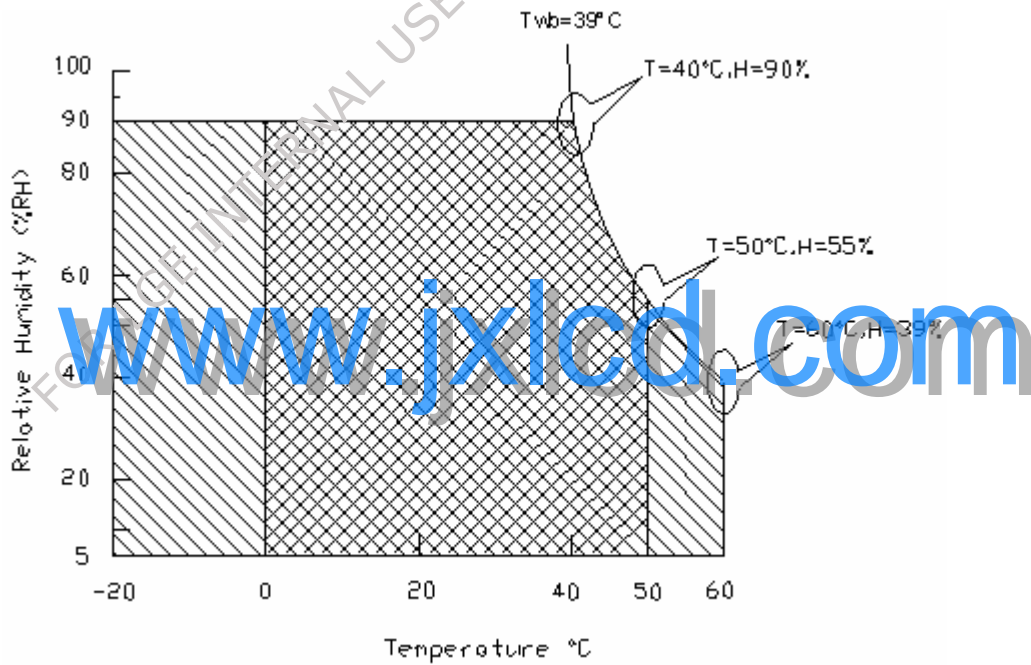

Operating Range



Storage Range

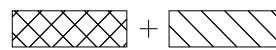

## 5. Electrical characteristics

### 5.1 TFT LCD Module

#### 5.1.1 Power Specification

Input power specifications are as follows:

Symble	Parameter	Min	Typ	Max	Units	Note
VDD	Logic/LCD Drive Voltage	3.0	3.3	3.6	[Volt]	±10%
IDD	VDD Current		800	910	[mA]	Vin=3.3V, Black Pattern, at 60Hz
IRush	Inrush Current		1.4	2	[A]	Note
PDD	VDD Power		2.6	3	[Watt]	Vin=3.3V, Black Pattern, at 60Hz

**Note:** Measure Condition

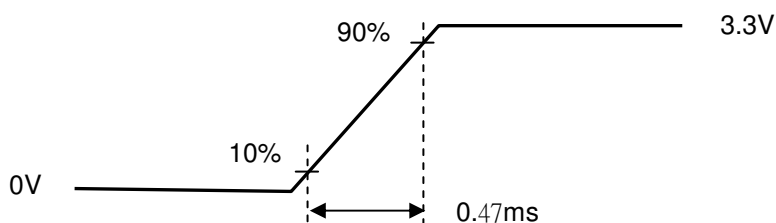
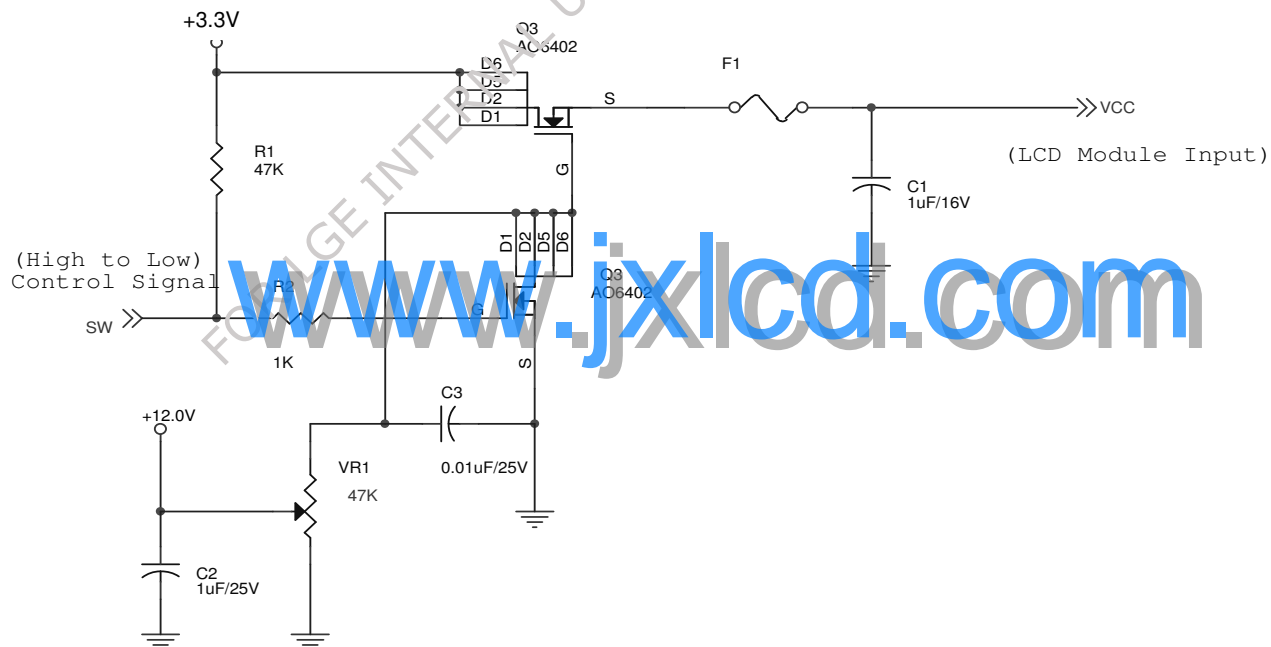

Vin rising time

## 5.1.2 Signal Electrical Characteristics

Input signals shall be low or Hi-Z state when  $V_{in}$  is off

It is recommended to refer the specifications of SN75LVDS82DGG (Texas Instruments) in detail.

Signal electrical characteristics are as follows:

Symbol	Parameter	Min	Typ	Max	Units	Condition	
VTH	Differential Input High Threshold	-	-	100	[mV]	$V_{ICM} = 1.2V$	<i>Note</i>
VTL	Differential Input Low Threshold	-100	-	-	[mV]	$V_{ICM} = 1.2V$	<i>Note</i>
VID	Input Differential Voltage	100	400	600	[mV]		<i>Note</i>
VICM	Differential Input Common Mode Voltage	1.0	1.2	1.5	[V]	$V_{TH}/V_{TL} = \pm 100mV$	<i>Note</i>

**Note:** LVDS Signal Waveform

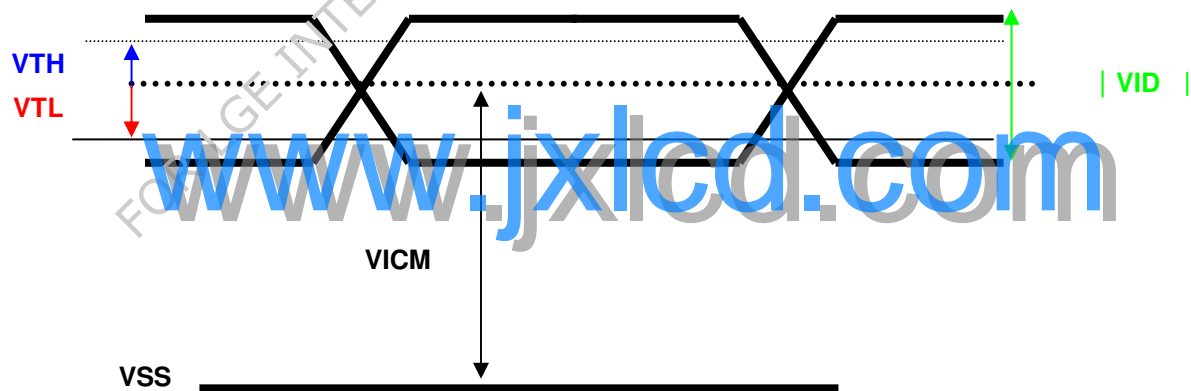

## 5.2 Backlight Unit

Parameter guideline for CCFL Inverter is under stable conditions at 25°C (Room Temperature) :

Symbol	Parameter	Min.	Typ.	Max.	Unit	Condition
IRCFL	CCFL operation range	3.0	7.5	8.0	[mA] rms	(Ta=25°C) Note 4
ICFL	CCFL Inrush current	-	-	20	[mA]	
FCFL	CCFL Frequency	40	50	80	[KHz]	(Ta=25°C) Note 1, 6
ViCFL (0°C) (reference)	CCFL Ignition Voltage	1450	-	-	[Volt] rms	(Ta=0°C) Note 3
ViCFL (25°C) (reference)	CCFL Ignition Voltage	1100	-	-	[Volt] rms	(Ta=25°C) Note 3
VCFL	CCFL Discharge Voltage	-	620 (@7.5mA)	710 (@3mA)	[Volt] rms	(Ta=25°C) Note 2
CFL	CCFL Power consumption @7.5mA	-	10	11	[Watt]	(Ta=25°C) Note 2
CCFL Life Time	LTCFL	40000	50000		[Hour]	Note 5

**Note 1:** CCFL frequency should be carefully determined to avoid interference between inverter and TFT LCD.

**Note 2:** Calculator value for reference (IRCFLxVCFLx2=PCFL).

**Note 3:** CCFL inverter should be able to give output a voltage more than 1450 volt. Lamp units need 1450 volt minimum for ignition.

**Note 4:** CCFL life time is 50,000hr at 7.5mA, it's defined as when the brightness is reduced by half. It's recommended not to exceed 7.5mA for CCFL life time concern and it's prohibited to exceed 8.0mA for safety concern.

**Note 5:** Definition of life: brightness becomes 50%. The typical life time of CCFL is under the condition at 8 mA lamp current.

**Note 6:** Requirement for system inverter design, which is intended to have a better display performance, a better power efficiency and a more reliable lamp. It should help increase the lamp lifetime and reduce its leakage current.

The frequency range will not affect to lamp lifetime and reliability characteristics. (Reference value)

The rate of unsymmetrical of lamp lighting waveform is shown (Lamp current waveform and lamp voltage waveform) at 10% or less.

$$\text{Asymmetrical} : ( | A | - | B | ) / | C | \leq 10 \%$$

A : Lamp current or lamp voltage o-p of +side

B : Lamp current or lamp voltage o-p of -side

C : Max(A,B) this is bigger in A or B

Recommendation lighting frequency : 50 ~ 60 KHz

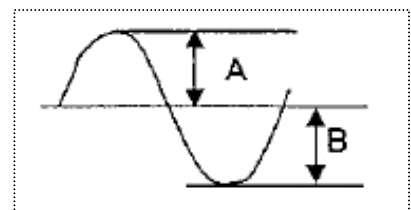

## 6. Signal Characteristic

### 6.1 Pixel Format Image

Following figure shows the relationship of the input signals and LCD pixel format.

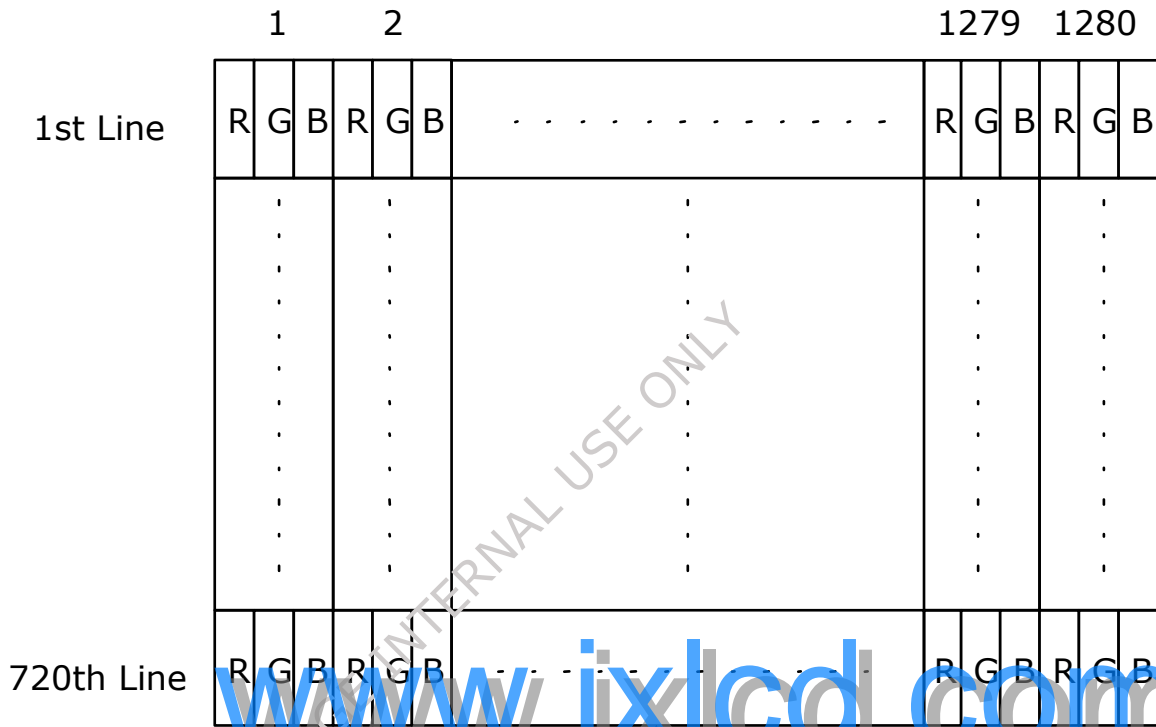



## 6.2 The Input Data Format

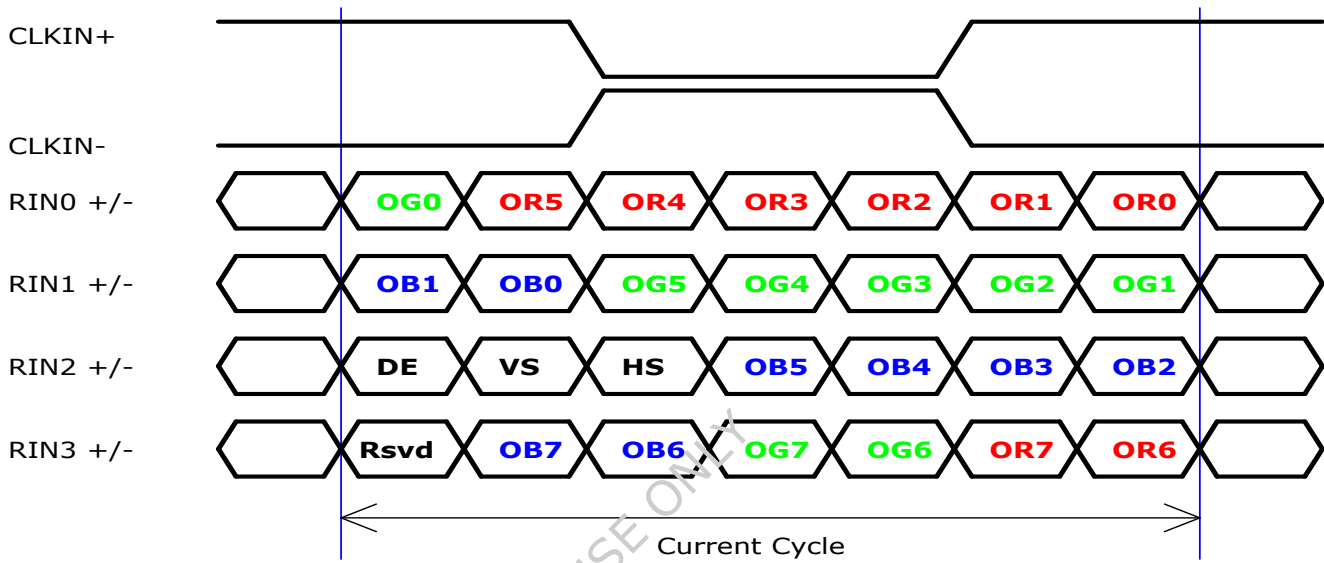

**Note1:** Please follow PSWG.

**Note2:** 8-bit in

**Note3:** R/G/B data 7:MSB, R/G/B data 0:LSB

[www.jxlcd.com](http://www.jxlcd.com)

## 6.3 Signal Description

The module using a pair of LVDS receiver SN75LVDS82(Texas Instruments) or compatible. LVDS is a differential signal technology for LCD interface and high speed data transfer device. Transmitter shall be SN75LVDS83(negative edge sampling) or compatible. The first LVDS port(RxOxxx) transmits odd pixels while the second LVDS port(RxExxx) transmits even pixels.

3 MSB240420 (STM)		
Pin No.	Symbol	Description
1	VDD	Power Supply, 3.3V (typical)
2	VDD	Power Supply, 3.3V (typical)
3	VSS	Ground
4	VSS	Ground
5	Rin0-	- LVDS differential data input (R0-R5, G0)
6	Rin0+	+ LVDS differential data input (R0-R5, G0)
7	VSS	Ground
8	Rin1-	- LVDS differential data input (G1-G5, B0-B1)
9	Rin1+	+ LVDS differential data input (G1-G5, B0-B1)
10	VSS	Ground
11	Rin2-	- LVDS differential data input (B2-B5, HS, VS, DE)
12	Rin2+	+ LVDS differential data input (B2-B5, HS, VS, DE)
13	VSS	Ground
14	ClkIN-	- LVDS differential clock input
15	ClkIN+	+ LVDS differential clock input
16	VSS	Ground
17	Rin3-	- LVDS differential data input (R6-R7, G6-G7, B6-B7)
18	Rin3+	+ LVDS differential data input (R6-R7, G6-G7, B6-B7)
19	VSS	Ground
20	VSS	Ground

**Note1:** Start from left side

**Note2:** Please follow PSWG.

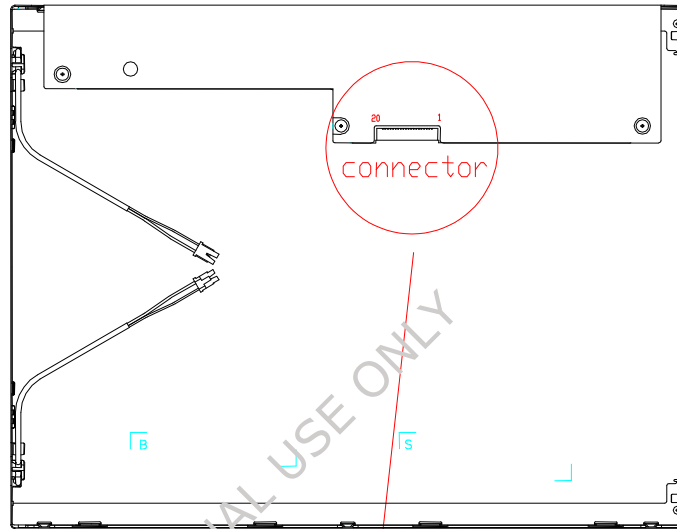

[www.jxlcd.com](http://www.jxlcd.com)

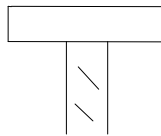
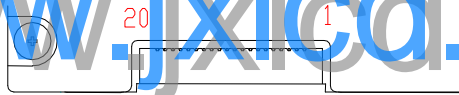

## 6.4 Interface Timing

### 6.4.1 Timing Characteristics

Signal	Item	Symbol	Min	Typ	Max	Unit
Clock Timing	Clock frequency	Tclk	50	62.18	81	MHz
Hsync Timing	Horizontal active	Thd	1280	1280	1280	Tclk
	Horizontal blanking(Note*)	Thbl	50	128	760	Tclk
	Horizontal period	Th	1320	1408	2040	Tclk
Vsync Timing	Vertical active	Tvd	720	720	720	Th
	Vertical blanking	Tvbl	10	16	220	Th
	Vertical period	Tv	730	736	940	Th
Frame Rate		F	50	60	75	Hz

**Note:** DE mode only

**Note:** Typical value refer to VESA STANDARD

**Note\*:** Horizontal Blanking do not set between 173~195, they will cause ASIC signal error.

[www.jxlcd.com](http://www.jxlcd.com)

## 6.4.2 Timing Diagram

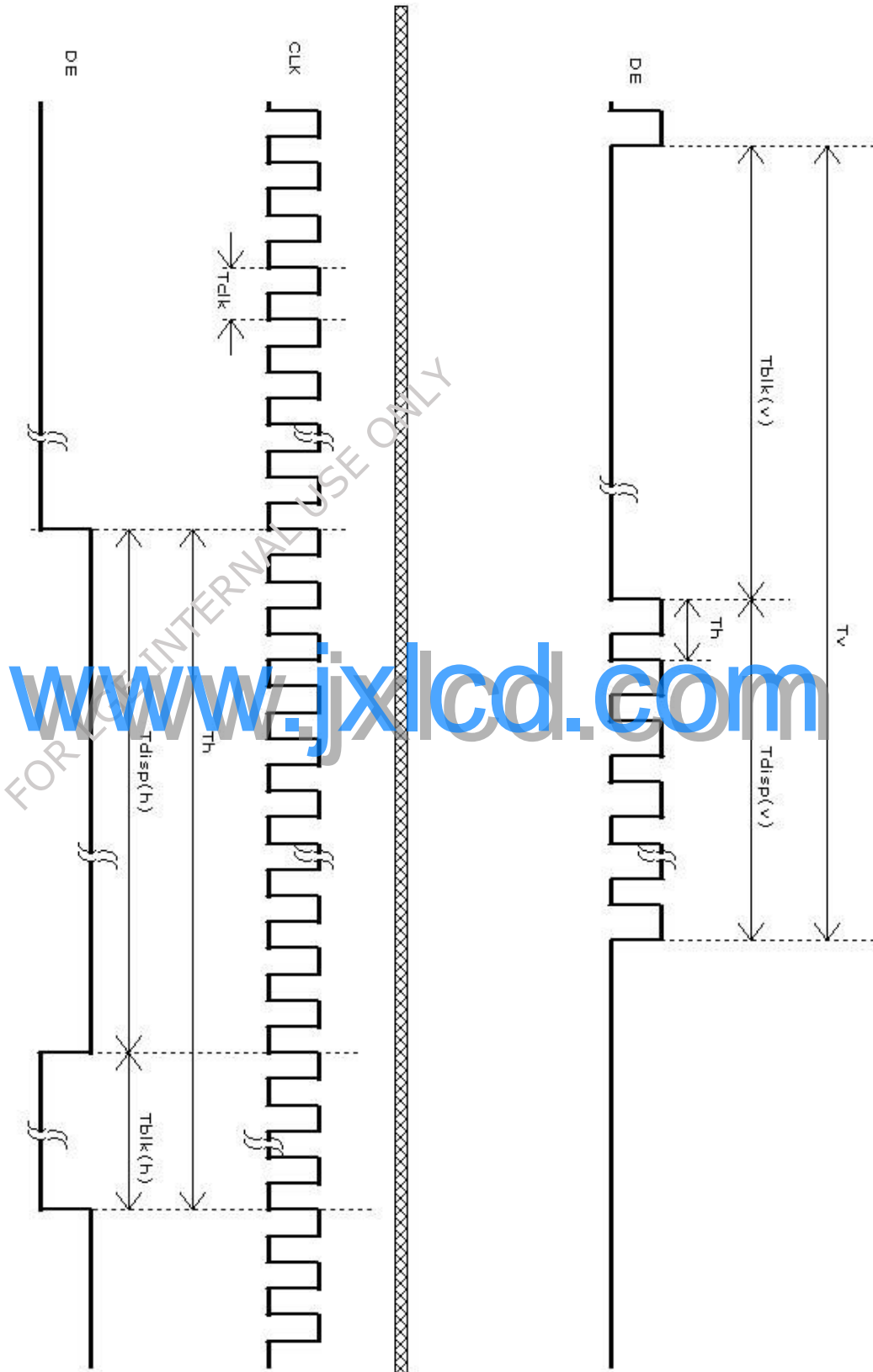

## 6.5 Power ON/OFF Sequence

Vin power and lamp on/off sequence is as follows. Interface signals are also shown in the chart. Signals from any system shall be Hi-Z state or low level when Vin is off.

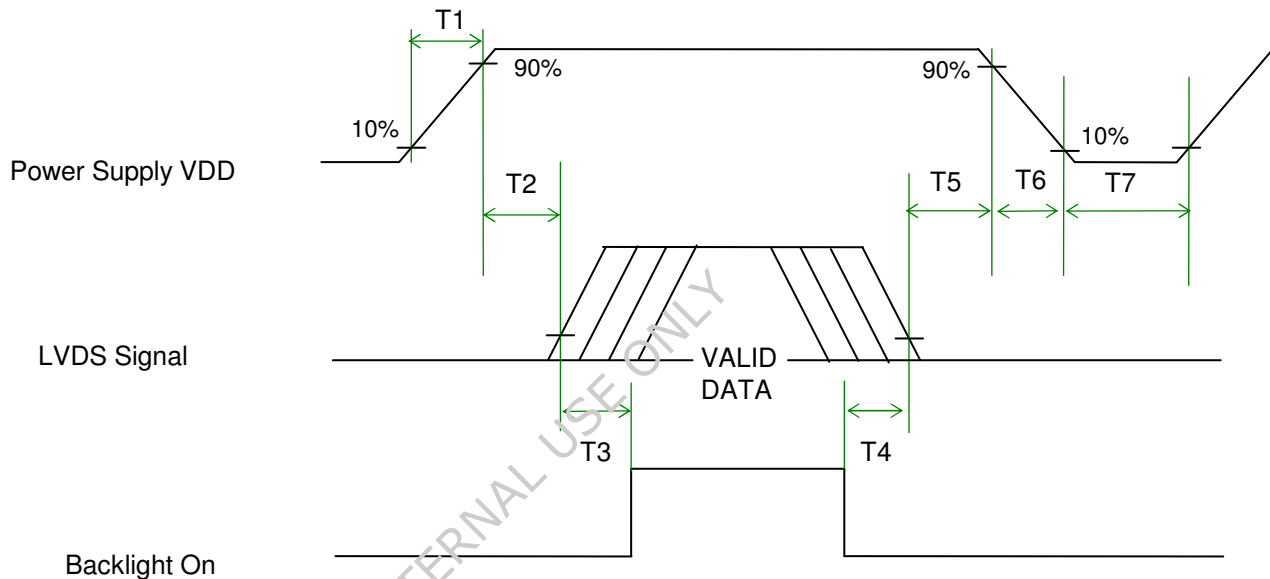

[www.jxlcd.com](http://www.jxlcd.com)  
Power Sequence Timing

Parameter	Value			Unit
	Min.	Typ.	Max.	
T1	0.5	-	10	[ms]
T2	30	40	50	[ms]
T3	200	-	-	[ms]
T4	100	-	-	[ms]
T5	0	16	50	[ms]
T6	-	-	10	[ms]
T7	1000	-	-	[ms]

## 7. Connector & Pin Assignment

Physical interface is described as for the connector on module. These connectors are capable of accommodating the following signals and will be following components.

### 7.1 TFT LCD Module

#### 7.1.1 Connector

Connector Name / Designation	Interface Connector / Interface card
Manufacturer	STM/ P-Two
Type Part Number	MSB240420E/ 185066-20121
Mating Housing Part Number	P240420

#### 7.1.2 Pin Assignment

Pin#	Signal Name	Pin#	Signal Name
1	VDD	2	VDD
3	VSS	4	VSS
5	Rin0-	6	Rin0+
7	VSS	8	Rin1-
9	Rin1+	10	VSS
11	Rin2-	12	Rin2+
13	VSS	14	ClkIN-
15	ClkIN+	16	VSS
17	Rin3-	18	Rin3+
19	VSS	20	VSS

## 7.2 Backlight Unit

Physical interface is described as for the connector on module. These connectors are capable of accommodating the following signals and will be following components.

Connector Name / Designation	Lamp Connector / Backlight lamp
Manufacturer	CviLux
Type Part Number	CP0502SL09
Mating Type Part Number	CP0502P1ML0-LF

### 7.2.1 Signal for Lamp connector

	Connector No.	Pin No.	Input	Color	Function
Upper	CN1	1	Hot1	Pink	High Voltage
		2	Cold1	White	Low Voltage

	Connector No.	Pin No.	Input	Color	Function
Lower	CN2	1	Hot1	Pink	High Voltage
		2	Cold1	White	Low Voltage



## 8. Reliability Test





Items	Required Condition	Note
Temperature Humidity Bias (THB)	Ta= 50□, 80%RH, 300hours	
High Temperature Operation (HTO)	Ta= 50□, 50%RH, 300hours	
Low Temperature Operation (LTO)	Ta= 0□, 300hours	
High Temperature Storage (HTS)	Ta= 60□, 300hours	
Low Temperature Storage (LTS)	Ta= -20□, 300hours	
Vibration Test (Non-operation)	Acceleration: 1.5 G Wave: Random Frequency: 10 - 200 - 10 Hz Sweep: 30 Minutes each Axis (X, Y, Z)	
Shock Test (Non-operation)	Acceleration: 50 G Wave: Half-sine Active Time: 20 ms Direction: ±X, ±Y, ±Z (one time for each Axis)	
Drop Test	Height: 46 cm, package test	
Thermal Shock Test (TST)	-20□/30min, 60□/30min, 100 cycles	1
On/Off Test	On/10sec, Off/10sec, 30,000 cycles	
ESD (Electro Static Discharge)	Contact Discharge: ± 8KV, 150pF(330Ω ) 1sec, 8 points, 25 times/ point.	2
	Air Discharge: ± 15KV, 150pF(330Ω ) 1sec 8 points, 25 times/ point.	
Altitude Test	Operation:10,000 ft Non-Operation:30,000 ft	

**Note 1:** The TFT-LCD module will not sustain damage after being subjected to 100 cycles of rapid temperature change. A cycle of rapid temperature change consists of varying the temperature from -20□ to 60□, and back again. Power is not applied during the test. After temperature cycling, the unit is placed in normal room ambient for at least 4 hours before power on.

**Note 2:** According to EN61000-4-2 , ESD class B: Some performance degradation allowed. No data lost. Self-recoverable. No hardware failures.

## 9. Shipping Label

The shipping label format is shown as below.

	Manufactured XX/XX Model No: M150EW02 V.X AU Optronics XXXXXX MADE IN XXXXXX (XX)	C <sup>AL</sup> US E204356	
*XXXXXXXXXXXXXXXX-XXXXX*			RoHS
			
XXXXXXXXXXXXXXXXXXXXXXXX			

FOR INTERNAL USE ONLY

[www.jxlcd.com](http://www.jxlcd.com)

# 10. Mechanical Characteristics

