

**CZT7120**  
**PNP SILICON SWITCHING POWER TRANSISTOR**

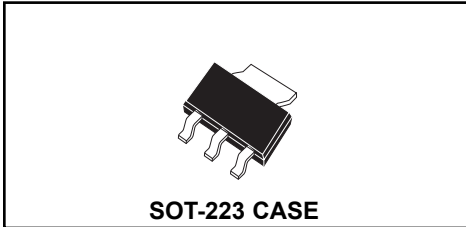

# Central<sup>TM</sup>

**Semiconductor Corp.**

**DESCRIPTION:**

The Central Semiconductor CZT7120 PNP Switching Power Transistor, manufactured by the epitaxial planar process, combines both power and high speed switching characteristics in a SOT-223 Surface Mount Package. Typical applications include drivers, DC-DC converters, and general fast switching applications.

**MAXIMUM RATINGS:** ( $T_A=25^{\circ}\text{C}$ )

	<b>SYMBOL</b>		<b>UNITS</b>
Collector-Base Voltage	$V_{CB0}$	120	V
Collector-Emitter Voltage	$V_{CEO}$	70	V
Emitter-Base Voltage	$V_{EBO}$	7.0	V
Collector Current	$I_C$	3.0	A
Power Dissipation	$P_D$	2.0	W
Operating and Storage Junction Temperature	$T_J, T_{stg}$	-65 to +150	$^{\circ}\text{C}$
Thermal Resistance	$\theta_{JA}$	62.5	$^{\circ}\text{C/W}$

**ELECTRICAL CHARACTERISTICS:** ( $T_A=25^{\circ}\text{C}$ )

<b>SYMBOL</b>	<b>TEST CONDITIONS</b>	<b>MIN</b>	<b>TYP</b>	<b>MAX</b>	<b>UNITS</b>
$I_{CBO}$	$V_{CB}=80\text{V}$			1.0	$\mu\text{A}$
$I_{EBO}$	$V_{EB}=5.0\text{V}$			1.0	$\mu\text{A}$
$BV_{CBO}$	$I_C=50\mu\text{A}$	120	156		V
$BV_{CEO}$	$I_C=10\text{mA}$	70	118		V
$BV_{EBO}$	$I_E=50\mu\text{A}$	7.0	24		V
$V_{CE(SAT)}$	$I_C=2.0\text{A}, I_B=200\text{mA}$		295	500	mV
$V_{BE(ON)}$	$I_C=2.0\text{A}, V_{CE}=1.0\text{V}$		0.93	1.1	V
$h_{FE}$	$V_{CE}=5.0\text{V}, I_C=10\text{mA}$	100	210		
$h_{FE}$	$V_{CE}=5.0\text{V}, I_C=500\text{mA}$	100	162	300	
$h_{FE}$	$V_{CE}=5.0\text{V}, I_C=3.0\text{A}$	40	65		
$f_T$	$V_{CE}=10\text{V}, I_C=500\text{mA}, f=1.0\text{MHz}$	8.0			MHz

**PNP SILICON SWITCHING  
POWER  
TRANSISTOR**

**SOT-223 CASE - MECHANICAL OUTLINE**

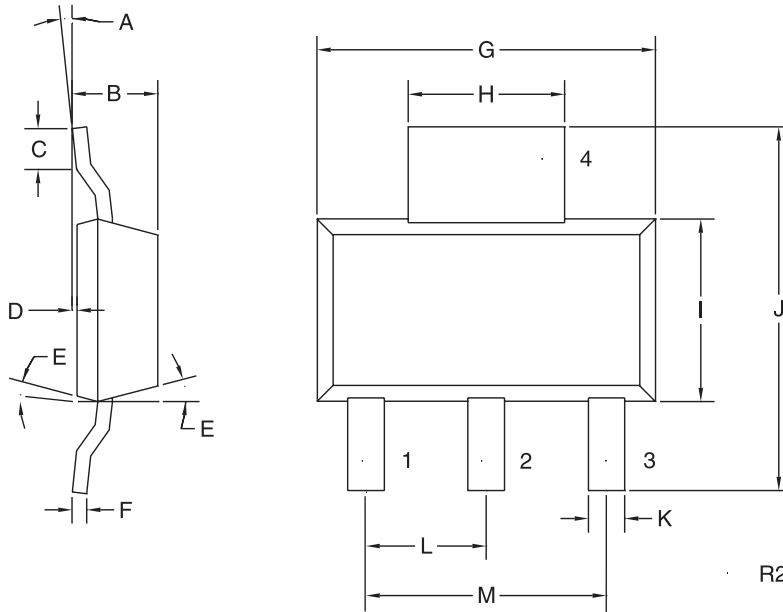

**LEAD CODE:**

- 1) Base
- 2) Collector
- 3) Emitter
- 4) Collector

SYMBOL	DIMENSIONS			
	INCHES		MILLIMETERS	
	MIN	MAX	MIN	MAX
A	0°	7°	0°	7°
B	0.063	0.067	1.60	1.70
C	0.022		0.55	
D	0.001	0.004	0.03	0.10
E	15°		15°	
F	0.009	0.013	0.23	0.33
G	0.248	0.264	6.30	6.71
H	0.114	0.122	2.90	3.10
I	0.130	0.146	3.30	3.71
J	0.264	0.287	6.71	7.29
K	0.024	0.031	0.61	0.79
L	0.091		2.31	
M	0.181		4.60	

SOT-223 (REV: R2)

R0 (14-March 2002)