

**AXICOM**

Telecom-, Signal and RF Relays

## Cradle Relay P v23003

---

## Cradle Relay P V23003

---

### Disclaimer

While Tyco Electronics has made every reasonable effort to ensure the accuracy of the information in this datasheet, Tyco Electronics does not guarantee that it is error-free, nor does Tyco Electronics make any other representation, warranty or guarantee that the information is accurate, correct, reliable or current. Tyco Electronics reserves the right to make any adjustments to the information contained herein at any time without notice. Tyco Electronics expressly disclaims all implied warranties (and all express warranties, except as otherwise stated in this datasheet) regarding the information contained herein, including but not limited to any implied warranties or merchantability or fitness for a particular purpose. It is recommended that you test any new or replacement product before incorporating into a system.

The dimensions in this datasheet are for reference purpose only and are subject to change without notice. Specifications are subject to change without notice.

### Index

Dimensions	4
Coil Data and operating range	5
Relay Code	6
Coil Data and Ordering Information	7
Instructions for Impulse Operation	9
Contact Data	10
Insulation / General Data	12

## Cradle Relay P V23003

Hand solder and plug-in relays,  
for DC operation,  
polarized, latching

ROHS compliant (Directive 2002/95/EC) as per  
product date code 0501.

### Features

- Primarily intended for impulse operation
- Highly reliable
- Multi purpose relay
- Great variety of contact arrangements and materials to meet specific applications
- Sockets for easy and quick mounting of relays (see datasheet Accessories)
- Contacts for signal loads and currents up to 5 A

### Typical applications

- For applications where the switching status must be maintained
- Measuring systems

### Relay types

- Size I or II, depending on contact set
- Standard contact sets with max. 4 changeover, 2 break contacts, special configurations on request
- Single or bifurcated contacts
- Hand solder terminals also for plug-in connection with screw fixing
- Dust-protected

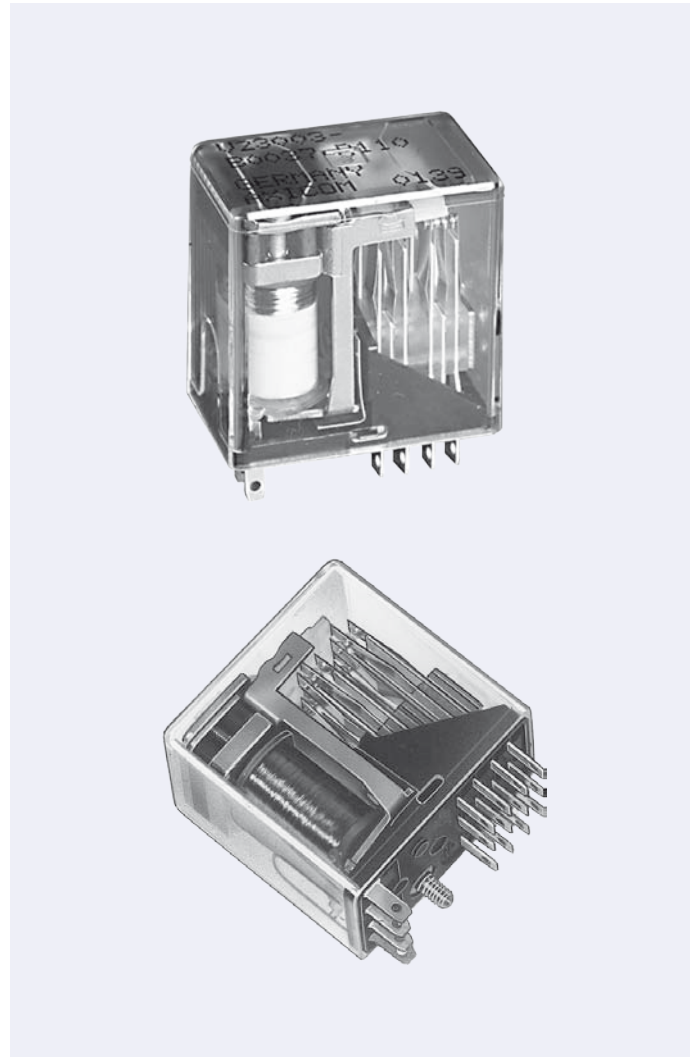

## Cradle Relay P V23003

### Dimensions

Dimensions in mm

#### Type V23003-A0xxx Size I

#### Type V23003-B0xxx Size II

Hand solder terminals, silver-plated  
Also for plug-in connection and screw fixing  
With earth terminal  
Dust-protected

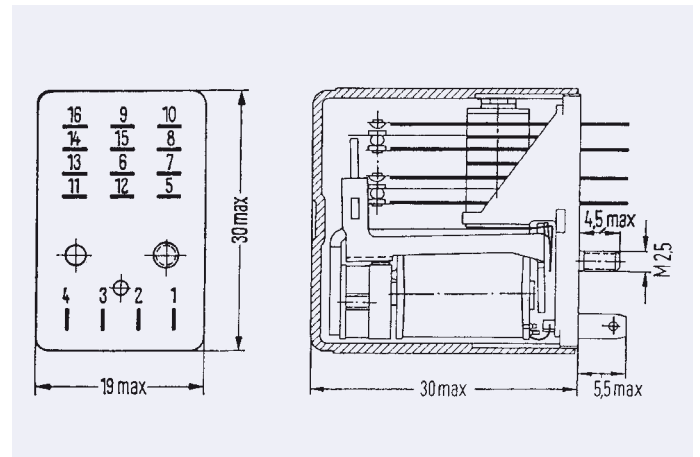
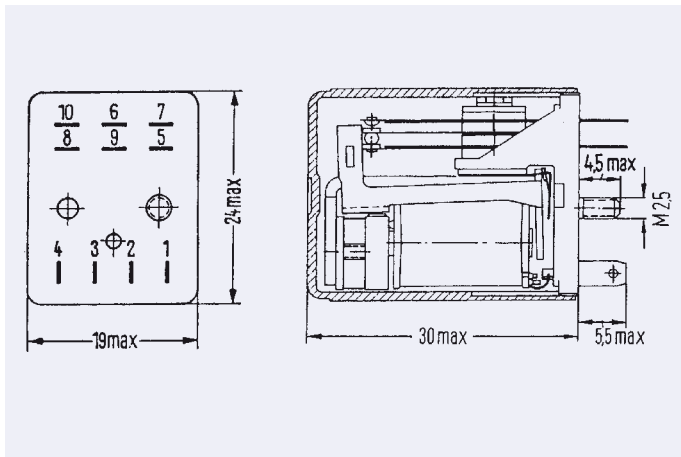

For sockets and hold-down springs see data sheet Accessories

## Cradle Relay P V23003

### Coil Data and operating range

Nominal voltage	from 6 Vdc to 60 Vdc
Typical nominal power consumption, at 20 °C	1.5 W
Class of the operative range acc to EN 61810-1 / IEC 61810-1 and VDE 0435 Part 201	1
Operating voltage (according to the coil type)	max. 73% of the nominal voltage

With continuous operation only one winding at a time may be energized within the specific voltage range.

The minimum voltage  $U_I$  and the maximum voltage  $U_{II}$  depends on the ambient temperature.

$$U_{I \text{ t amb}} = U_{I \text{ 20 °C}} \cdot k_{I \text{ t amb}}$$

$$U_{II \text{ t amb}} = U_{II \text{ 20 °C}} \cdot k_{II \text{ t amb}}$$

$t_{\text{amb}}$  = Ambient temperature

$U_{I \text{ t amb}}$  = Minimum voltage at ambient temperature,  $t_{\text{amb}}$

$U_{II \text{ t amb}}$  = Maximum voltage at ambient temperature,  $t_{\text{amb}}$

$k_I$  and  $k_{II}$  = Factors

Operate - negative potential at start of winding

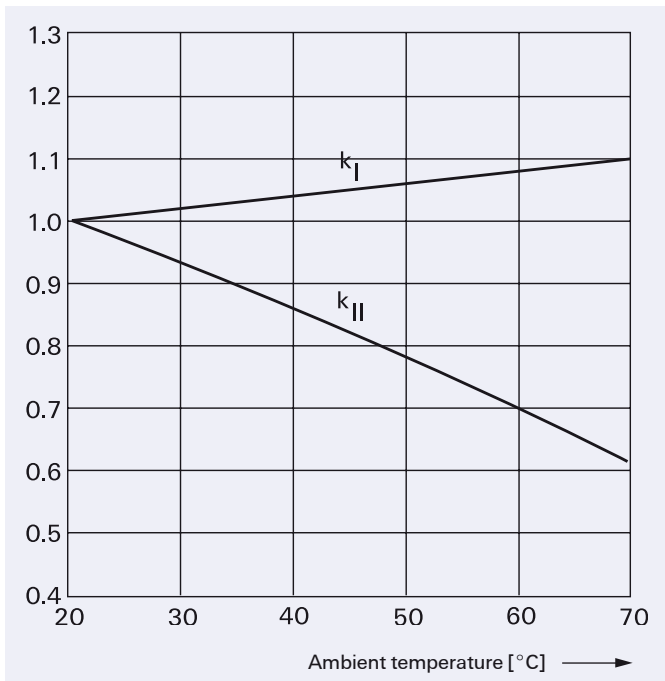

Release - plus potential at start of winding

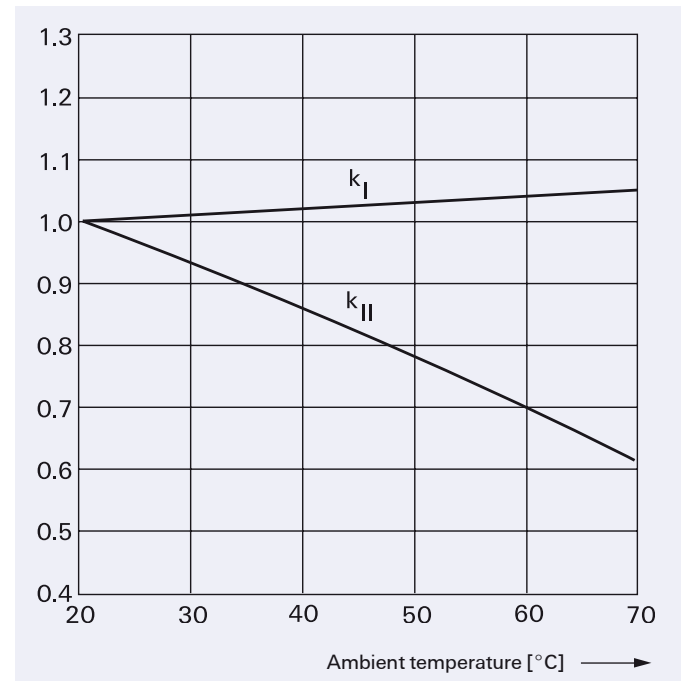

## Cradle Relay P V23003

### Relay Code

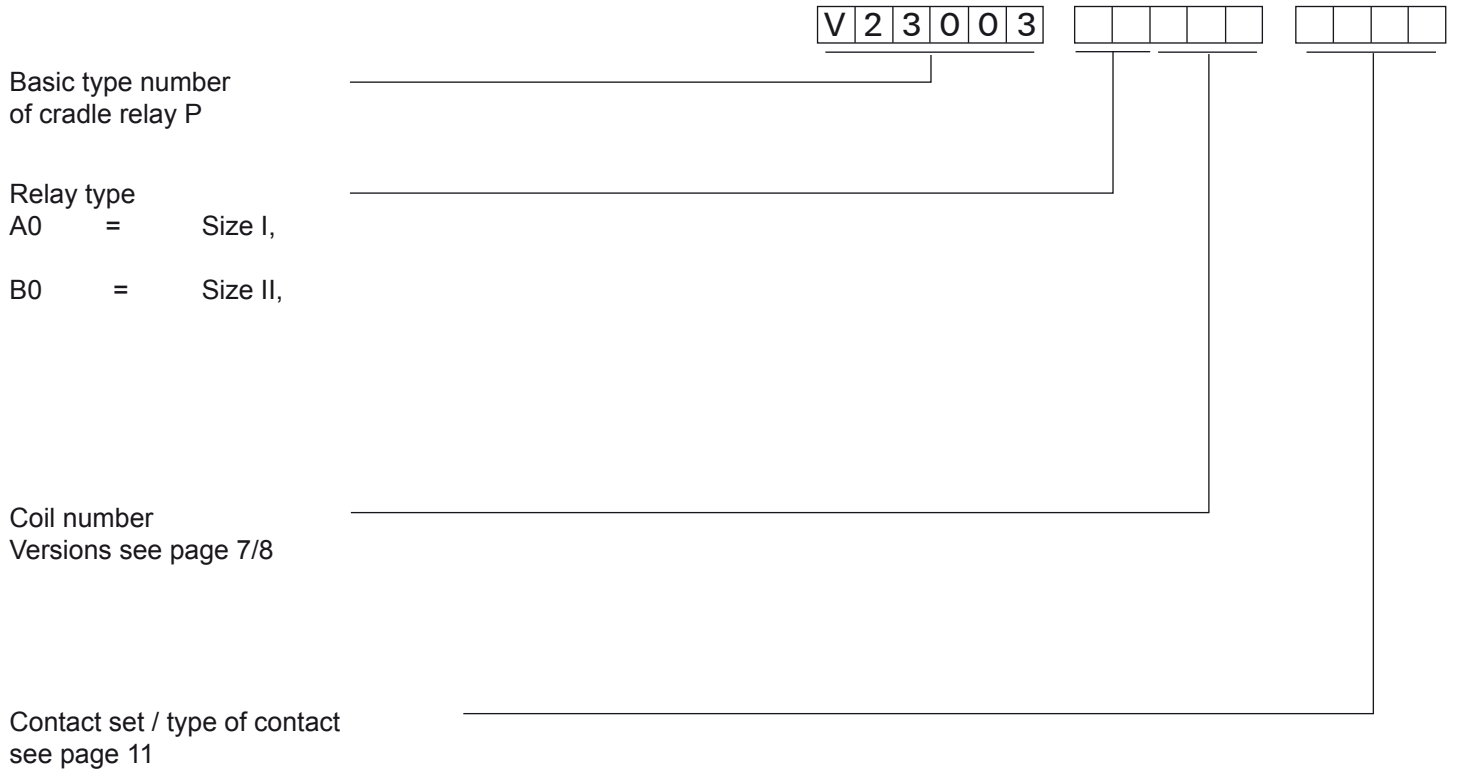

Ordering example:  
V23003-B0037-F104  
Cradle relay P, size II, dust-protected, coil 24 Vdc, 2 changeover contact set, single contacts, contact material silver, gold-flashed

Note:  
The ordering scheme enables a multitude of variations. However, not all variations are defined as construction specifications (ordering code) and thus in the current delivery program.

Special design can be carried out to customer specifications. Please contact your local representative.

## Cradle Relay P V23003

### Coil Data (values at 23 °C)

### Ordering Information

Nominal voltage Unom  Vdc	Operate/set voltage range		Coil power  mW	Winding	Terminals		Coil Resistance  $\Omega / \pm 15 \%$	Relay code	Tyco part number
	Minimum voltage Umin Vdc	Maximum voltage Umax Vdc			Start	End			

#### V23003-AXXXX standard, size I

12.00	8.00	13.50	1'440	I	3	2	100	V23003A25B104	1393817-4
	8.00	13.50		II	4	1	100		
12.00	8.00	13.50	1'440	I	3	2	100	V23003A25C104	1393817-5
	8.00	13.50		II	4	1	100		
24.00	16.50	26.50	1'440	I	3	2	400	V23003A37B104	1393817-7
	16.50	25.00		II	4	1	340		
24.00	16.50	26.50	1'440	I	3	2	400	V23003A37B604	1393817-8
	16.50	25.00		II	4	1	340		
24.00	16.50	26.50	1'440	I	3	2	400	V23003A37C104	1393817-9
	16.50	25.00		II	4	1	340		
60.00	44.00	65.00	1'500	I	3	2	2400	V23003A44B104	1-1393817-8
	44.00	65.00		II	4	1	2400		
48.00	33.50	49.00	1'646	I	3	2	1400	V23003A64B104	2-1393817-0
	33.50	49.00		II	4	1	1400		
48.00	33.50	49.00	1'646	I	3	2	1400	V23003A64B604	2-1393817-1
	33.50	49.00		II	4	1	1400		
48.00	33.50	49.00	1'646	I	3	2	1400	V23003A64C104	2-1393817-2
	33.50	49.00		II	4	1	1400		

#### V23003-AXXXX 5A, size I

6.00	4.00	6.70	1'469	I	3	2	24.5	V23003A26F106	1393817-6
	4.00	6.70		II	4	1	24.5		
24.00	16.50	26.50	1'440	I	3	2	400	V23003A37F101	1-1393817-0
	16.50	25.00		II	4	1	340		
24.00	16.50	26.50	1'440	I	3	2	400	V23003A37F105	1-1393817-1
	16.50	25.00		II	4	1	340		
24.00	16.50	26.50	1'440	I	3	2	400	V23003A37F106	1-1393817-2
	16.50	25.00		II	4	1	340		

## Cradle Relay P V23003

### Coil Data (values at 23 °C)

### Ordering Information

Nominal voltage Unom	Operate/set voltage range		Coil power	Winding	Terminals		Coil Resistance	Relay code	Tyco part number
	Minimum voltage Umin	Maximum voltage Umax			Start	End			
Vdc	Vdc	Vdc	mW				Ω / ± 15 %		

#### V23003-BXXXX standard, size II

12.00	8.00	13.50	1'440	I	3	2	100	V23003B25B110	3-1393817-1
	8.00	13.50		II	4	1	100		
12.00	8.00	13.50	1'440	I	3	2	100	V23003B25C110	3-1393817-2
	8.00	13.50		II	4	1	100		
6.00	4.00	6.70	1'469	I	3	2	24.5	V23003B26B110	3-1393817-4
	4.00	6.70		II	4	1	24.5		
6.00	4.00	6.70	1'469	I	3	2	24.5	V23003B26C110	3-1393817-5
	4.00	6.70		II	4	1	24.5		
24.00	16.50	26.50	1'440	I	3	2	400	V23003B37B110	3-1393817-9
	16.50	25.00		II	4	1	340		
24.00	16.50	26.50	1'440	I	3	2	400	V23003B37B610	4-1393817-0
	16.50	25.00		II	4	1	340		
24.00	16.50	26.50	1'440	I	3	2	400	V23003B37C110	4-1393817-1
	16.50	25.00		II	4	1	340		
24.00	16.50	26.50	1'440	I	3	2	400	V23003B37C112	4-1393817-2
	16.50	25.00		II	4	1	340		
24.00	16.50	26.50	1'440	I	3	2	400	V23003B37C116	1413004-2
	16.50	25.00		II	4	1	340		
24.00	16.50	26.50	1'440	I	3	2	400	V23003B37C117	4-1393817-3
	16.50	25.00		II	4	1	340		
24.00	16.50	26.50	1'440	I	3	2	400	V23003B37C410	4-1393817-4
	16.50	25.00		II	4	1	340		
60.00	44.00	65.00	1'500	I	3	2	2400	V23003B44B110	5-1393817-4
	44.00	65.00		II	4	1	2400		
60.00	44.00	65.00	1'500	I	3	2	2400	V23003B44B129	5-1393817-5
	44.00	65.00		II	4	1	2400		
60.00	44.00	65.00	1'500	I	3	2	2400	V23003B44B610	1413004-1
	44.00	65.00		II	4	1	2400		
60.00	44.00	65.00	1'500	I	3	2	2400	V23003B44B610	1-1419137-0
	44.00	65.00		II	4	1	2400		
60.00	44.00	65.00	1'500	I	3	2	2400	V23003B44C110	5-1393817-6
	44.00	65.00		II	4	1	2400		
60.00	44.00	65.00	1'500	I	3	2	2400	V23003B44W84	5-1393817-8
	44.00	65.00		II	4	1	2400		
48.00	33.50	49.00	1'646	I	3	2	1400	V23003B64B110	6-1393817-3
	33.50	49.00		II	4	1	1400		
48.00	33.50	49.00	1'646	I	3	2	1400	V23003B64C110	6-1393817-4
	33.50	49.00		II	4	1	1400		

#### V23003-BXXXX 5A, size II

12.00	8.00	13.50	1'440	I	3	2	100	V23003B25F104	3-1393817-3
	8.00	13.50		II	4	1	100		
6.00	4.00	6.70	1'469	I	3	2	24.5	V23003B26F104	3-1393817-6
	4.00	6.70		II	4	1	24.5		
24.00	16.50	26.50	1'440	I	3	2	400	V23003B37F104	4-1393817-5
	16.50	25.00		II	4	1	340		
60.00	44.00	65.00	1'500	I	3	2	2400	V23003B44F104	5-1393817-7
	44.00	65.00		II	4	1	2400		
48.00	33.50	49.00	1'646	I	3	2	1400	V23003B64F104	6-1393817-5
	33.50	49.00		II	4	1	1400		



## Cradle Relay P V23003

### Instructions for Impulse Operation

Cradle relay P is primarily intended for impulse operation. The maximum voltage stated in the table (page 2) can be increased for impulse operation as follows:

$$\begin{aligned}
 U_{II \text{ Impuls}} &= U_{II \text{ tamb}} \cdot q \\
 U_{II \text{ tamb}} &= \text{Maximum continuous voltage at ambient temperature } t_{\text{amb}} \\
 q &= \text{Factor}
 \end{aligned}$$

The impulse voltage must not exceed 80% of the test voltage (winding/frame or winding/winding) or 3.3 times at ambient temperature = 20 °C and 2.3 times at ambient temperature < 20 °C the value of the maximum voltage listed in the table (page 2).

$$\text{If } t_{ED} \leq 3 \text{ s then } q = \sqrt{\frac{t_z}{t_{ED}}}$$

$$\begin{aligned}
 \text{If } t_{ED} &= \text{Pulse width} \\
 t_z &= \text{Cycle time} \\
 \text{If } t_{ED} &= > 3 \text{ s the value of } q \text{ must be obtained from the nomograph (cradle relay N datasheet page 103).}
 \end{aligned}$$

Examples of various periodic pulse trains (energizing side)

#### 1. Periodic recurrence of one energizing pulse

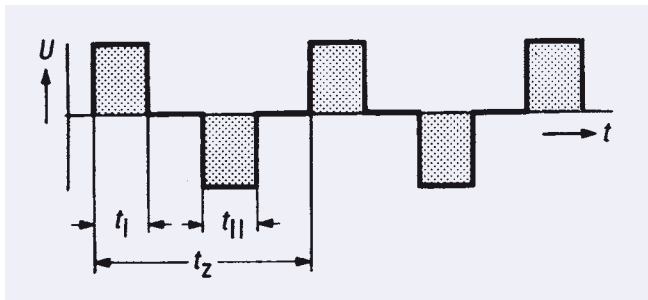

$$\begin{aligned}
 t_{ED} &= t_I + t_{II} \\
 t_I &= \text{Pulse width of the positive pulse at the start of the winding} \\
 t_I + t_{II} &= \text{Pulse width of the negative pulse at the start of the winding} \\
 t_I + t_{II} &= \text{Pulse widths within one cycle}
 \end{aligned}$$

#### 2. Periodic recurrence of two unequal energizing pulses

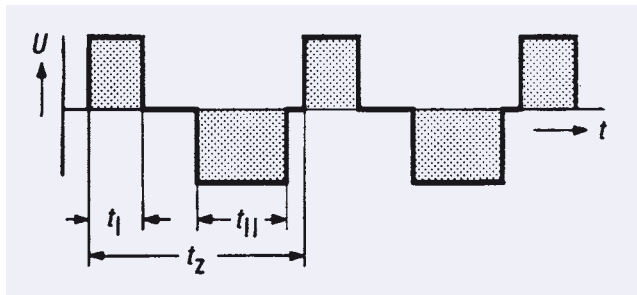

## Cradle Relay P V23003

### Contact Data

Ordering code block 3	B104/B110	B604/B610	C104/C110	C404/C410	F104 ... F107
Number of contacts and Type	max. 4 changeover contacts, 2 break contacts or 2 make contacts				
Contact assembly	single contacts		bifurcated contacts		single contacts
Contact material	silver, gold-flashed	gold F	silver, gold-flashed	gold F	silver, gold-flashed
Max. switching voltage	150 Vdc	36 Vdc	150 Vdc	36 Vdc	250 Vdc
	125 Vac	30 Vac	125 Vac	30 Vac	250 Vac
Max. switching current	2 A	0.2 A	2 A	0.2 A	5 A
Max. switching capacity	35 to 70 W see load limit curve page 10 50 VA	5 W 5 VA	35 to 70 W see load limit curve page 10 50 VA	5 W 5 VA	50 to 140 W see load limit curve page 10 500 VA
Max. continuous current at max. ambient temperature	2 A				5 A

### Max. DC Load Breaking Capacity

for contact sets B1xx and C1 xx

Safe breaking, no stationary arc  
Contact material silver, gold-flashed

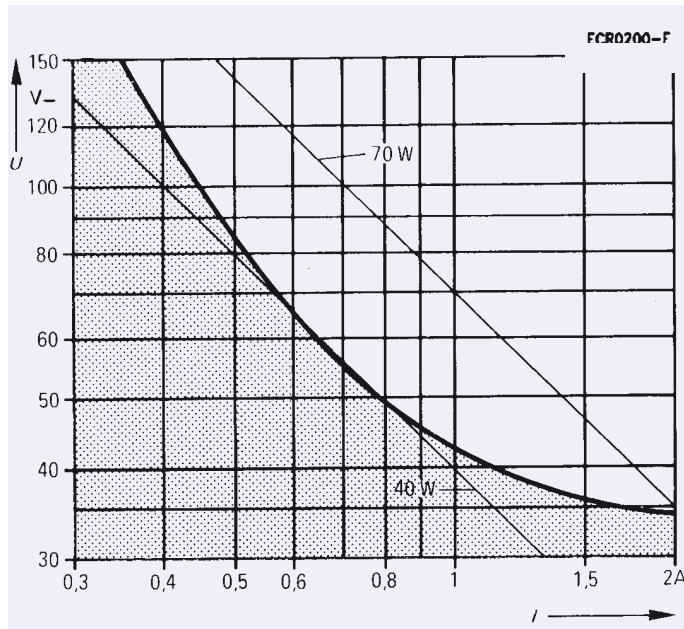

$I$  = switching current  
 $U$  = switching voltage

for contact sets F1xx

Safe breaking, no stationary arc  
Contact material silver, gold-flashed

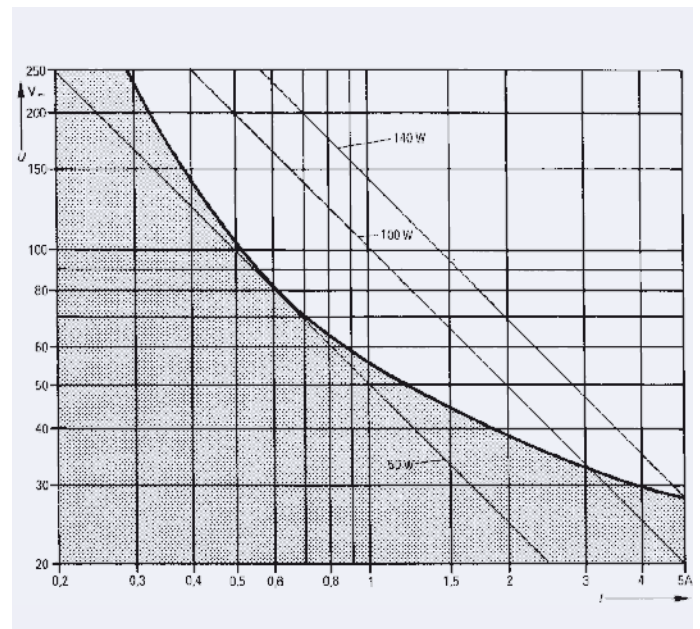

$I$  = switching current  
 $U$  = switching voltage

## Cradle Relay P V23003

### Contact sets

#### Size I

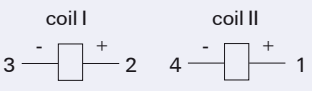
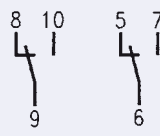
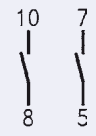
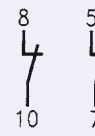
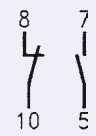
Number of contacts and type	2 changeover contacts		2 make contacts	2 break contacts	1 break 1 make contact
Symbols with base connections  Contacts in release condition, coil polarity to set the relay					
Contact assembly	single contacts	bifurcated contacts	single contacts		
Contact material silver, gold-flashed Ordering code block 3	B104	C104	F105	F107	F106
Contact material gold F Ordering code block 3	B604	C404			

#### Size II

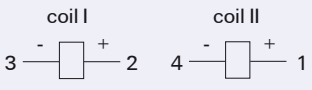
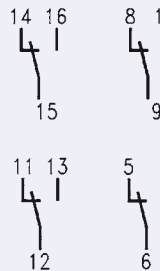
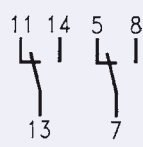
Number of contacts and type	4 changover contacts		2 changover contacts
Symbols with base connections  Contacts in release condition, coil polarity to set the relay			
Contact assembly	single contacts	bifurcated contacts	single contacts
Contact material silver, gold-flashed Ordering code block 3	B110	C110	F104
Contact material gold F Ordering code block 3	B610	C410	

## Cradle Relay P V23003

### Insulation

Ordering code block 3	B1xx	B6xx	C1xx	C4xx	F1xx
Test voltage (1 min) winding / frame contact / contact contact / frame		500 Vac <sub>rms</sub> 500 Vac <sub>rms</sub> 500 Vac <sub>rms</sub>			500 Vac <sub>rms</sub> 1000 Vac <sub>rms</sub> 1000 Vac <sub>rms</sub>

### General Data

Ordering code block 3	B1xx	B6xx	C1xx	C4xx	F1xx
Operate time at $U_{nom}$ and 20 °C, typical	4 ms				
Reset time typical	4 ms				
Maximum switching rate without load	20 operations/s				
Ambient temperature range acc. to EN 61810-1 / IEC 61810-1 and VDE 0435 part 201	-40 °C ... +70 °C				
Thermal resistance	50 K/W				
Maximum temperature	100 °C				
Continuous thermal load	1.6 W				
Degree of protection acc. to EN 60529 / IEC 60529 / VDE 0470 part 1	dust-protected IP 30				
Mechanical endurance	approx. 10 <sup>7</sup> operations				
Mounting position	any				
Weight V23003-A0xxx Size I V23003-B0xxx Size II	approx. 25 g approx. 30 g				

## Cradle Relay P V23003

### IM Relays

4th generation slim line – low profile polarized 2 c/o telecom signal relay with bifurcated contacts, available as non latching or latching relay with 1 coil. Nominal voltage range from 1.5 ... 24 V, coil power consumption of 50 ... 200 mW, latching relays with 1 coil 100 mW. The IM relay is available as through hole and surface mount type (J-Legs and Gull Wings) and capable to switch loads up to 60 W/62,5 VA. It is currently the only 2 A rated 4G relay on the market. Dielectric strength fulfills the Telcordia requirements according GR 1089 (2,5 kV – 2 / 10 µs) and FCC part 68 (1,5 kV – 10 / 160 µs). The IM relay is tested according CECC/IECQ and certified in accordance with IEC/EN 60950 and UL 60950.

Dimensions approx. 10 x 6 mm board space and 5.65 mm height.

### P2 Relays

3rd generation polarized 2 c/o telecom relay with bifurcated contacts, available as non latching or latching relay with 1 or 2 coils. Nominal voltage range from 3 ... 24 V, coil power consumption 140 mW, latching relays with 1 coil 70 mW. The P2 Relay is available as through hole or surface mount type and capable to switch currents up to 5 A. Dielectric strength fulfills the Telcordia requirements according GR 1089 (2,5 kV – 2 / 10 µs) and FCC part 68 (1,5 kV – 10 / 160 µs). The P2 relay is tested according CECC/IECQ and certified in accordance with IEC/EN 60950 and UL 60950. Dimensions approx. 15 x 7,5 mm board space and 10 mm height.

### FX2 Relays

3rd generation polarized 2 c/o telecom relay with bifurcated contacts, available as non latching or latching relay with 1 coil. Nominal voltage range from 3 ... 48 V, coil power consumption of 80 ... 260 mW for the high sensitive version, 140... 300 mW for the standard version, latching relays with 1 coil 100 mW. The FX2 relay is available as through hole type and capable to switch loads up to 60 W/62,5 VA. Dielectric strength fulfills the Telcordia requirements according GR 1089 (2,5 kV – 2 / 10 µs) and FCC part 68 (1,5 kV – 10 / 160 µs). The FX2 relay is tested according CECC/IECQ and certified in accordance with IEC/EN 60950 and UL 60950. Dimensions approx. 15 x 7,5 mm board space and 10,7 mm height.

### FT2 / FU2 Relays

3rd generation non polarized, non latching 2 c/o telecom relay with bifurcated contacts. Nominal voltage range from 3 ... 48 V, coil power consumption 200 ... 300 mW. Most sensitive 48 V relay. Available as through hole and surface mount type. Dielectric strength fulfills the Telcordia requirements according GR 1089 (2,5 kV – 2 / 10 µs) and FCC part 68 (1,5 kV – 10 / 160 µs). The FT2/FU2 relay is tested according CECC/IECQ and certified in accordance with IEC/EN 60950 and UL 60950. Dimensions approx. 15 x 7,5 mm board space and 10 mm height.

### FP2 Relays

3rd generation polarized 2 c/o telecom relay with bifurcated contacts, available as non latching or latching relay with 1 or 2 coils. Nominal voltage range from 3 ... 48 V, coil power consumption of 80 ... 260 mW for the high sensitive version, 140... 300 mW for the standard version, latching relays with 1 coil 100 mW. The FP2 Relay is available as through hole type and capable to switch loads up to 60 W/62,5 VA. Dielectric strength fulfills FCC part 68 (1,5 kV – 10 / 160 µs). The FP2 is tested according CECC/IECQ approved.

Dimensions approx. 14 x 9 mm board space and 5 mm height.

### MT2

2nd generation non polarized, non latching 2 c/o telecom and signal relay with bifurcated contacts. Nominal voltage range from 3 ... 48 V, coil power consumption 150/200/300/400 and 550 mW. Dielectric strength fulfills the requirements according FCC part 68 (1,5 kV – 10 / 160 µs).

Dimensions approx. 20 x 10 mm board space and 11 mm height.

### D2n Relays

2nd generation non polarized 2 c/o relay for telecom and various other applications. Nominal voltage range from 3 ... 48 V, coil power consumption from 150 ... 500 mW. The D2n relay is capable to switch currents up to 3 A. Dielectric strength fulfills the requirements according FCC part 68 (1,5 kV – 10 / 160 µs). Dimensions approx. 20 x10 mm board space and 11 mm height.

### P1 Relays

Extremely sensitive, polarized 1 c/o relay with bifurcated contacts for a wide range of applications, available as non latching or latching relay with 1 or 2 coils. Nominal voltage range from 3 ... 24 V, coil power consumption 65 mW, latching relays with 1 coil 30 mW. The P1 relay is available as through hole or surface mount type and capable to switch currents up to 1 A. Dielectric strength fulfills the requirements according FCC part 68 (1,5 kV – 10 / 160 µs). Dimensions approx. 13 x 7,6 mm board space and 7 mm height for THT or 8 mm height for SMT version.

### W11 Relays

Low cost, non polarized 1 c/o relay for various applications. Nominal voltage range from 3 ... 24 V, coil power consumption 450 mW, sensitive versions 200 mW. The W11 relay is capable to switch currents up to 3 A. Dielectric strength 1000 Vrms.

Dimensions approx. 15,6 x 10,6 mm board space and 11,5 mm height.

### Reed Relays

High sensitive, non polarized relay for telecom and various other applications, available with 1 n/o, 2 n/o or 1c/o contacts. Nominal voltage range from 5 ... 24 V, coil power consumption 50...280 mW for 1 n/o and 125 ... 280 mW for 2 n/o or 1 c/o versions. Reedrelays are available in DIP or SIL housing and capable to switch currents up to 0,5 A. Integrated diode and/or electrostatic shield optional. Dielectric strength 1500 Vdc. Dimensions approx. 19,3 x 7 mm board space and 5 ... 7,5 mm height for DIP or 19,8 x 5 mm board space and 7,8 mm height for SIL version.

### Cradle Relays

Extremely reliable and mature relay family of 1st generation for various signal switching applications. Available as non polarized, polarized / latching and relay with AC coil. The benefit is the possibility of combining various contact sets from 1 up to 6 poles, single and bifurcated contacts, different contact materials with a coil voltage range from 1,5 Vdc to 220 Vac. Cradle relays are available as dust protected and hermetically sealed versions, with plug in or solder terminals and are capable to switch currents up to 5 A. Forcibly guided (linked) contact sets optional. Dielectric strength 500 Vrms. Dimensions from approx. 19 x 24 to 19x35 mm board space and 30 mm height.

### Other Relays

We offer a variety of different relay families for maintenance and replacement purposes. These relays are up to 60 years old now, such as Card Relay SN (V23030 series), Small General Purpose Relay (V23006 series), Small Polarized Relay (V23063 ... V23067 and V23163 ... V23167 series). Accessories like sockets, hold down springs, etc. optional.

### High Frequency Relays

HF3 / HF3S / HF6 series RF relays offering excellent RF characteristics in a small package. All HF series relays are suitable for SMD soldering processes. Available as non latching or latching versions with 1 or 2 coils and a nominal coil voltage range from 3 ... 24 V, a coil power consumption of 140 mW or 70 mW (single coil latching types).

**HF3:** Low cost RF relay suitable up to 3 GHz. Impedance 50 and 75 Ohm. 50 W hot switching and 50 W RF power carry capability. Dimensions 14.6 x 7.3 x 10.3 mm.

**HF3S:** High performance, high power RF relay suitable up to 3 GHz, 50 W hot switching and 150 W RF power carry capability. Dimensions 15 x 7.6 x 10.6 mm.

**HF6:** High performance, high power RF relay suitable up to 6 GHz, 50 W hot switching and 50 W RF power carry capability. Dimensions 15 x 7.6 x 10.6 mm.



Tyco Electronics Logistics AG  
Werk Axicom Au  
Seestrasse 295  
CH-8804 Au-Wädenswil / Switzerland  
Phone +41 44 782 91 11  
Fax +41 44 782 90 00  
E-mail: [axicom@tycoelectronics.com](mailto:axicom@tycoelectronics.com)



Tyco Electronics  
Paulsternstrasse 26  
D-13629 Berlin / Germany  
Phone +49 30 386 38573  
Fax +49 30 386 38575  
E-mail: [axicom@tycoelectronics.com](mailto:axicom@tycoelectronics.com)



Tyco Electronics EC Trutnov s.r.o.  
Komenského 821  
CZ-541 01 Trutnov / Czech Republic  
E-mail: [axicom@tycoelectronics.com](mailto:axicom@tycoelectronics.com)

# AXICOM

Telecom-, Signal and RF Relays

Tyco Electronics Corporation  
POB 3608,  
Harrisburg, PA 17105, USA  
Phone +1 800-522-6752

 **Tyco Electronics**

Our commitment. Your advantage.