

RECOMMENDED MOUNTING HOLE PATTERN FOR 1.60 [.063] THICK P.C. BOARD  $\Delta 2$

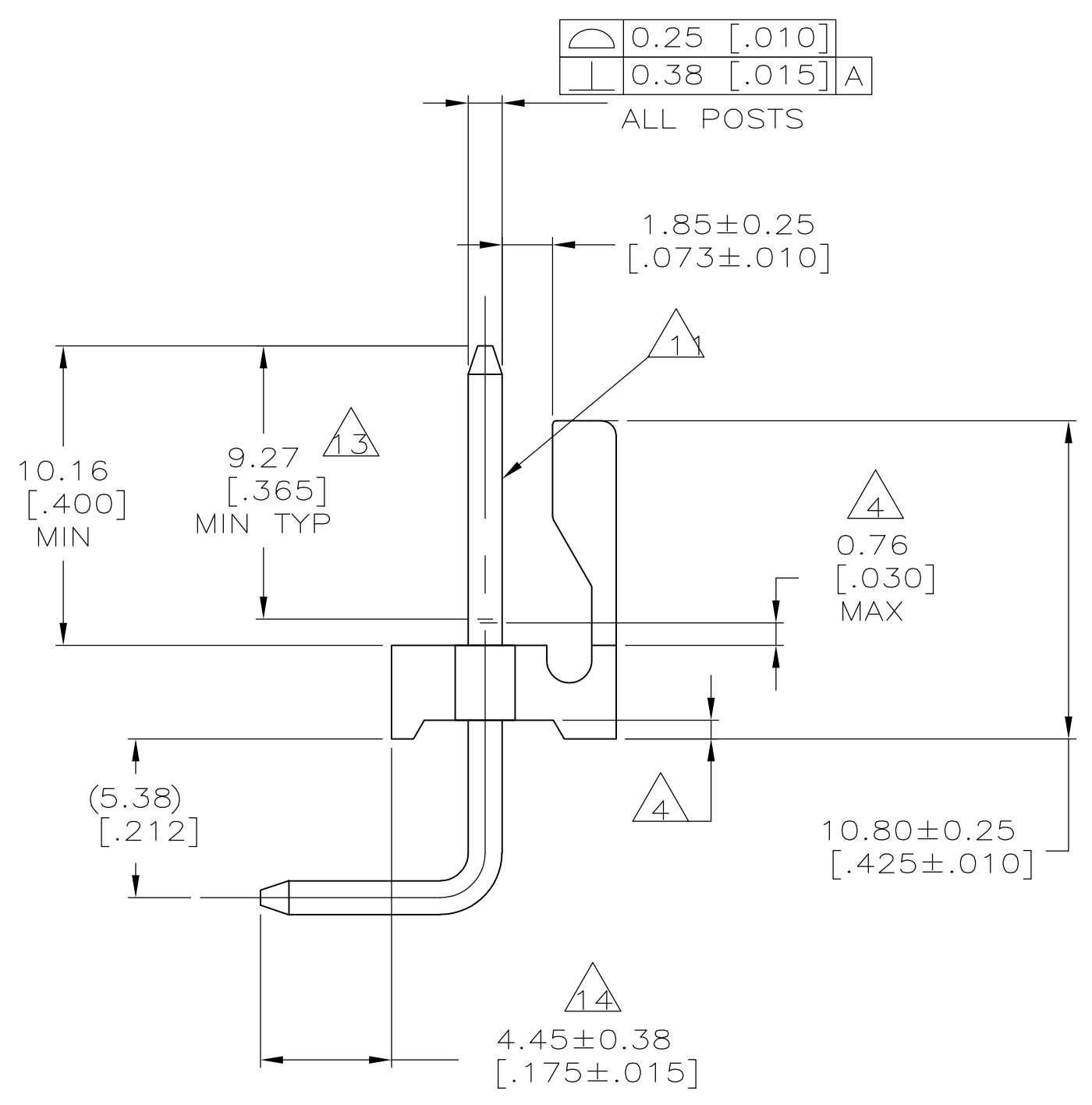
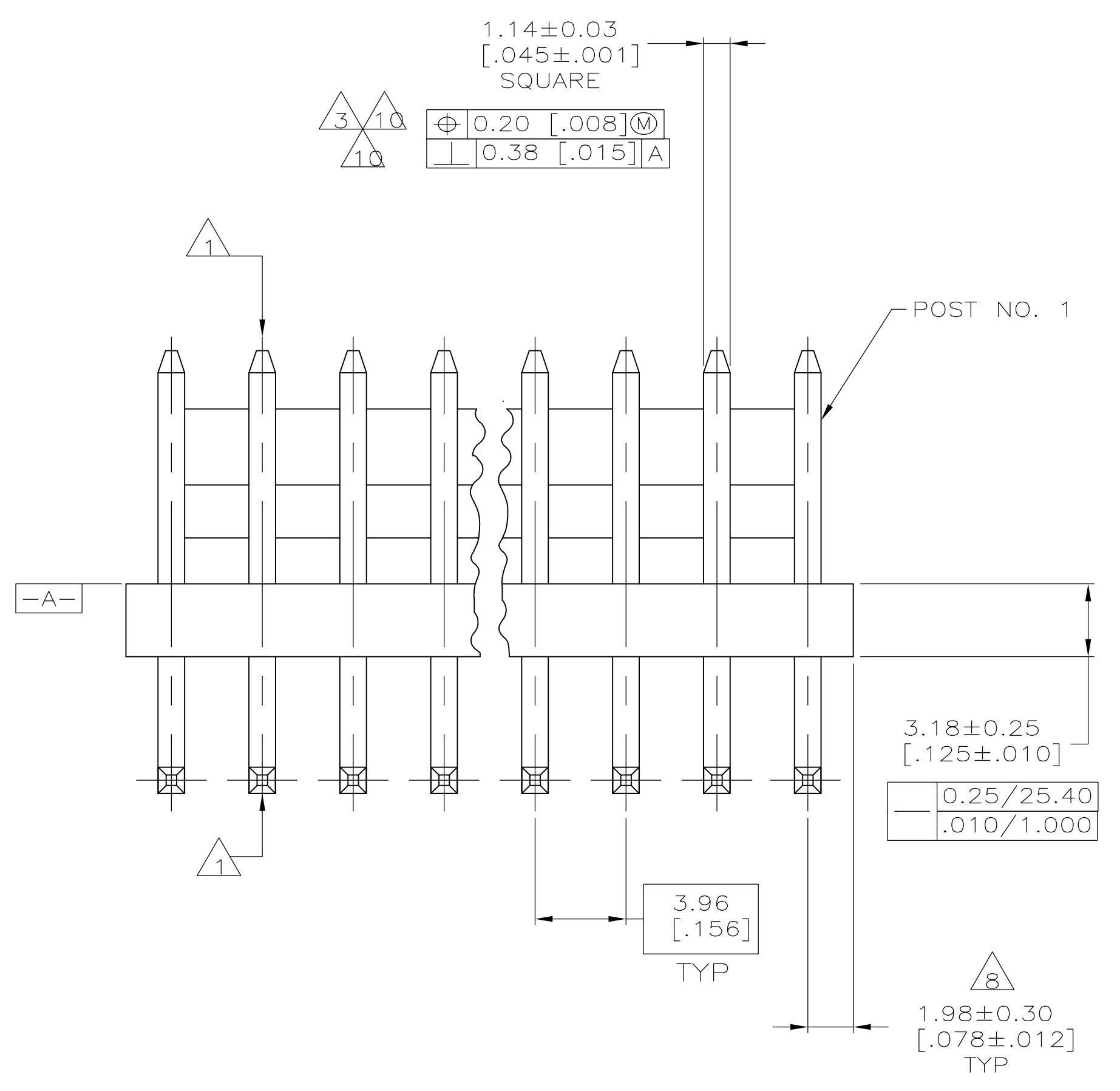
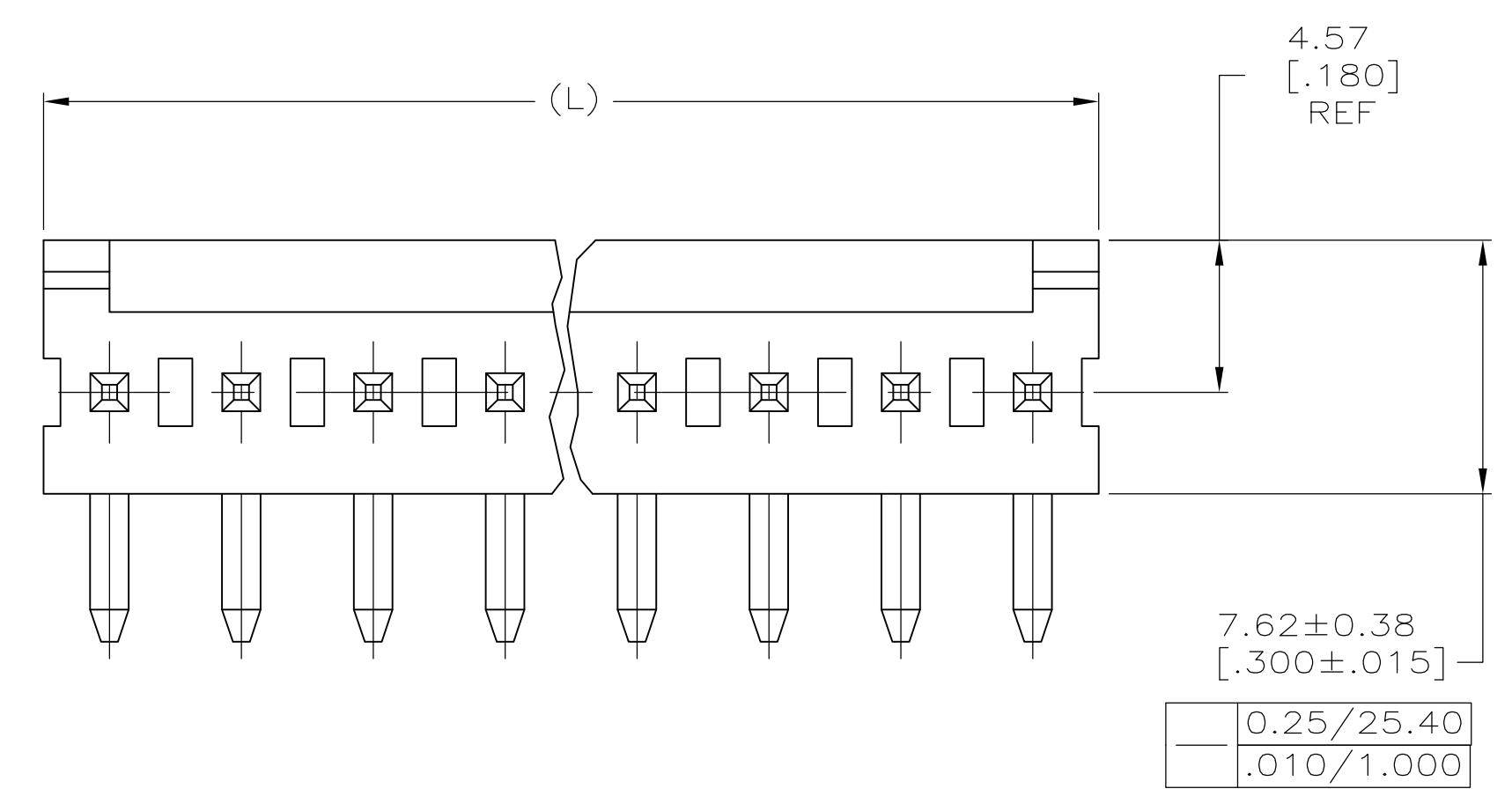

DIM (L)	NO. OF POSN	ASSEMBLY
95.10 [3.744]	24	5-644768-4
91.14 [3.588]	23	5-644768-3
87.17 [3.432]	22	5-644768-2
83.21 [3.276]	21	5-644768-1
79.25 [3.120]	20	5-644768-0
75.29 [2.964]	19	4-644768-9
71.32 [2.808]	18	4-644768-8
67.36 [2.652]	17	4-644768-7
63.40 [2.496]	16	4-644768-6
59.44 [2.340]	15	4-644768-5
55.47 [2.184]	14	4-644768-4
51.51 [2.028]	13	4-644768-3
47.55 [1.872]	12	4-644768-2
43.59 [1.716]	11	4-644768-1
39.62 [1.560]	10	4-644768-0
35.66 [1.404]	9	3-644768-9
31.70 [1.248]	8	3-644768-8
27.74 [1.092]	7	3-644768-7
23.77 [.936]	6	3-644768-6
19.81 [.780]	5	3-644768-5
15.85 [.624]	4	3-644768-4
11.89 [.468]	3	3-644768-3
7.92 [.312]	2	3-644768-2

DIM (L)	NO. OF POSN	ASSEMBLY
95.10 [3.744]	24	2-644768-4
91.14 [3.588]	23	2-644768-3
87.17 [3.432]	22	2-644768-2
83.21 [3.276]	21	2-644768-1
79.25 [3.120]	20	2-644768-0
75.29 [2.964]	19	1-644768-9
71.32 [2.808]	18	1-644768-8
67.36 [2.652]	17	1-644768-7
63.40 [2.496]	16	1-644768-6
59.44 [2.340]	15	1-644768-5
55.47 [2.184]	14	1-644768-4
51.51 [2.028]	13	1-644768-3
47.55 [1.872]	12	1-644768-2
43.59 [1.716]	11	1-644768-1
39.62 [1.560]	10	1-644768-0
35.66 [1.404]	9	644768-9
31.70 [1.248]	8	644768-8
27.74 [1.092]	7	644768-7
23.77 [.936]	6	644768-6
19.81 [.780]	5	644768-5
15.85 [.624]	4	644768-4
11.89 [.468]	3	644768-3
7.92 [.312]	2	644768-2

- $\Delta 1$  POST TO WITHSTAND 13 NEWTONS (3 LBS) MINIMUM AXIAL FORCE IN BOTH DIRECTIONS SHOWN WITHOUT DISLODGING.
- $\Delta 2$  TOLERANCES APPLY TO SOLDER SIDE OF BOARD.
- $\Delta 3$  MEASURED AT SURFACE  $\Delta A$
- $\Delta 4$  PLASTIC FLASH PERMITTED IN THIS AREA.
- 5 PARTS COMPLY WITH AMP SOLDERABILITY SPEC. NO. 109-11-2.
- $\Delta 6$  ONE HOLE MAY BE UNDERSIZED 1.65/1.52 [.065/.060] DIA. FOR ASSEMBLY RETENTION DURING WAVE SOLDERING.
- $\Delta 7$  MATERIAL: HEADER-THERMOPLASTIC POLYESTER GLASS-FILLED 94V-0 (NATURAL) POST-COPPER ALLOY (SEE NOTES 13 & 14 FOR PLATING)
- $\Delta 8$  COORDINATE DIMENSION APPLIES FROM CENTER OF ACTUAL FEATURE.
- 9 PLASTIC BURRS CAUSED BY CUT-OFF TOOLING ARE PERMITTED WITHIN THE MAXIMUM TOLERANCE ENVELOPE.
- $\Delta 10$  POST TO BE MEASURED WHEN STRIP IS HELD FLAT.
- $\Delta 11$  POST MUST WITHSTAND TWO 90° BENDS AGAINST EXTRUSION WITHOUT BREAKING.
- $\Delta 12$  DIMENSION SHOULD BE 8.26-10.16 [.325-.400] MIN WHEN MATING WITH A MTA-156 CONNECTOR ASSEMBLY OR 8.26-8.76 [.325-.345] MIN WHEN MATING WITH A SL-156 CONNECTOR ASSEMBLY.
- $\Delta 13$  PLATING: GOLD PLATE AREA, 0.00038 [.000015] GOLD OR 0.00008 [.000003] MIN GOLD FLASH OVER 0.00030 [.000012] PALLADIUM NICKEL, PER TE CONNECTIVITY'S DISCRETION, ALL SIDES, OVER NICKEL UNDERPLATE, 0.00127 [.000050] MIN, ALL SIDES AND ENTIRE LENGTH OF POST.
- $\Delta 14$  PLATING: BRIGHT TIN/LEAD (93/7) PLATE AREA, 0.00381-0.00889 [.000150-.000350] THICK, ALL FOUR SIDES 4.45 [.175] MINIMUM FOR -2 THRU -24. MATTE TIN PLATE AREA 0.00381-0.00889 [.000150-.000350] THICK ALL FOUR SIDES, 4.45 [.175] FOR -32 THRU -54.
- $\Delta 15$  OBSOLETE PARTS: OBSOLETE CIS STREAMLINING PER D.RENAUD/D.SINISI

**METRIC**

THIS DRAWING IS A CONTROLLED DOCUMENT.

DIMENSIONS: mm [INCHES]	TOLERANCES UNLESS OTHERWISE SPECIFIED:	DIN S. HOOVER 07NOV02	TE Connectivity
$\phi$	0 PLC ± -	CHK: D. ROSSI 07NOV02	NAME: MTA-156 HEADER ASSEMBLY, FRICTION LOCK, RIGHT ANGLE, FRONT BEND, .045 SQUARE POST, .000015 GOLD, SPECIAL
$\pm$	1 PLC ± ±	APVD: D. ROSSI 07NOV02	APPLICATION SPEC
$\pm$	2 PLC ± ± 0.13[.005]	SIZE: A1	CAGE CODE: 00779
$\pm$	3 PLC ± ±	WEIGHT: -	DRAWING NO: 644768
$\pm$	4 PLC ± ±	CUSTOMER DRAWING	SCALE: 5:1 SHEET 1 OF 1 REV G
ANGLES	FINISH		