

## Wide Input Range CC/CV Step Down Converter

### General Description

The NT3875 is a step down PWM converter with driving a output current up to 2A (NT3875A) and 1A (NT3875B) without a additional transistor. It is designed to allow for operating a wide supply voltage range from 8V to 40V. The external shutdown function can be controlled by logic level to pull COMP/EN pin down, and then comes into standby mode. The external compensation makes feedback control have good line and load regulation with flexible external design.

The NT3875 features a programmable CV/CC mode control functions. The CV mode (constant voltage) function provides a regulated voltage output and the CC mode (constant current) function provides a current limitation function. The CC current value is set by external resistor during current sense amplifier input stage.

The NT3875 is suitable for the DC/DC switching power applications when requested the current limit function. The devices are available in SOP-8L and PSOP-8L packages and require very few external devices for operation.

### Applications

- Car Charger
- Portable Charger Devices
- High-Brightness Lighting
- General-Purpose DC/DC Converters with Current Limit

### Features

- $V_{IN}$  Operate with 8V ~ 40V Supply Voltage
- $V_{OUT}$  Accuracy ( $V_{ref} = 1.2V$ )  $\pm 1.0\%$  Over Line Voltage
- CC / CV Mode Control (Constant Current and Constant Voltage)
- $\pm 5\%$  Current Limit Accuracy
- Output Short Circuit Protection
- Output Over Voltage Protection ( $\sim 120\%$ )
- Over Temperature Protection
- Internal Soft Start  $\sim 7ms$
- Fixed Frequency 120 KHz
- UVLO Protection (min=6V, typ=7V, max=8V)
- Duty Cycle Range (0~90%)
- Single Pin to External Compensation and Shutdown Control
- Integrated Power N-MOSFET
  - $R_{ds\_on} = 150m\ \Omega$  for NT3875A
  - $R_{ds\_on} = 240m\ \Omega$  for NT3875B
- (P)SOP- 8L Package

### Ordering Information

Order Number	Package	Remark
NT3875ASA8	SOP-8	Output Current = 2
NT3875ASW8	PSOP-8	Output Current = 2
NT3875BSA8	SOP-8	Output Current = 1

Note: NT products are compatible with the current IPC/JEDEC J-STD-020 requirement. They are halogen-free, RoHS compliant and 100% matte tin (Sn) plating that are suitable for use in SnPb or Pb-free soldering processes.

### Pin Configuration

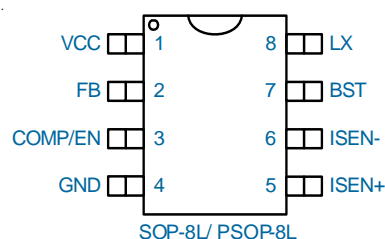

Typical Application Circuit

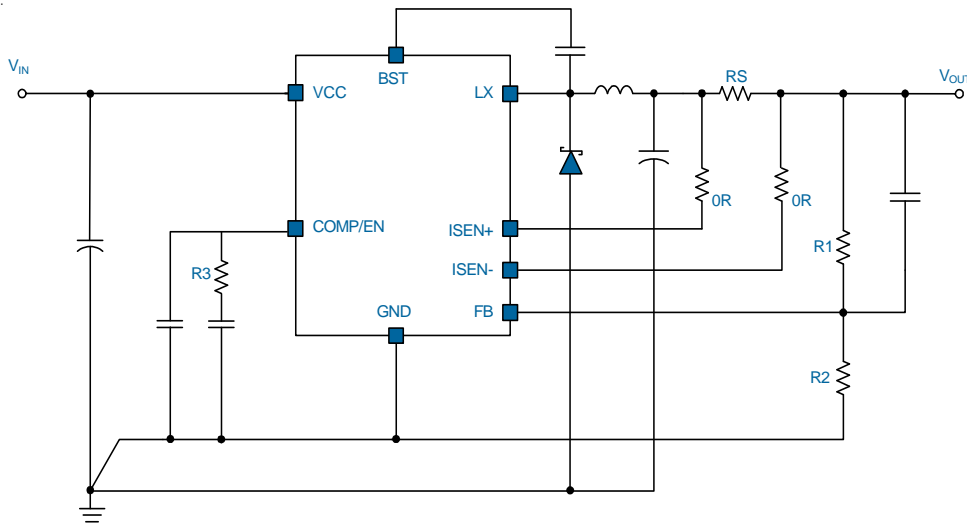

Functional Pin Description

No.	Pin Name	Pin Function
1	VCC	<b>Power Supply Input.</b> Bypass this pin with a 10uF ceramic capacitor to GND, placed as close to the IC as possible.
2	FB	<b>Feedback Pin.</b> The voltage at this pin is regulated to 1.2V. Connect to the resistor divider between output and GND to set the output voltage.
3	COMP/EN	<b>Error Amplifier Output.</b> This is the output of the error amplifier (EA) and the non-inverting input of the PWM comparator. Use this pin in combination with the VSEN pin to compensate the voltage control feedback loop of the converter. Pulling COMP/EN to a level below 0.4V nominal disables the controller, causes the oscillator to stop, and makes the UGATE and LGATE outputs held low.
4	GND	<b>Ground.</b> Connect this pin to a large PCB copper area for best heat dissipation, Return VSEN, and COMP to this GND and connect this GND to power GND at a single point for best noise immunity.
5	ISEN+	<b>The Current Sense Input (+) Pin.</b>
6	ISEN-	<b>The Current Sense Input (-) Pin.</b>
7	BST	<b>Bootstrap Pin.</b> This provides power to the internal higher MOSFET gate driver. Connect a 10nF capacitor from BST pin to LX pin.
8X	L	<b>Power Switching Output to External Inductor.</b>

Functional Block Diagram

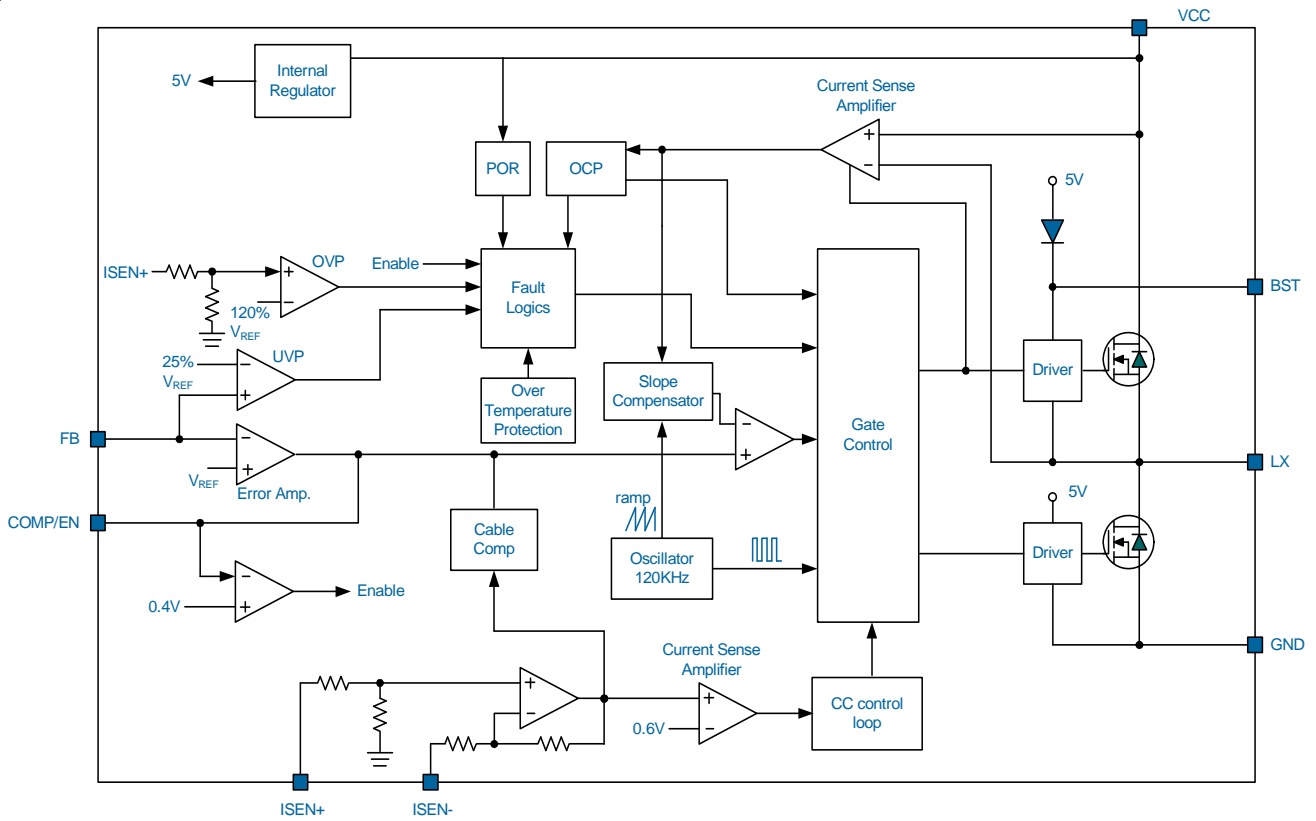

### Absolute Maximum Rating

Supply Input Voltage, $V_{CC}$ (Note1)	-----	-0.3V to +45V
BST to LX	-----	0.3V to +7V
LX to GND DC	-----	-1V to +VIN+1V
BST to GND DC	-----	VSW -0.3 to VSW+7V
FB, COMP to GND DC	-----	0.3V to +7V
ISEN-, ISEN+ to GND DC	-----	0.3V to +9V
Storage Temperature Range	-----	-65°C to +150°C
Junction Temperature	-----	-20°C to +150°C
Lead Temperature Range(Soldering 10sec)	-----	260°C
ESD Rating (Note2)		
HBM(Human Body Mode)	-----	2KV
MM(Mechine Mode)	-----	200V

### Thermal Information

#### Package Thermal Resistance (Note 3)

SOP-8L $\theta_{JA}$	-----	160°C/W
SOP-8L $\theta_{JC}$	-----	39°C/W
PSOP-8L $\theta_{JA}$	-----	50°C/W
PSOP-8L $\theta_{JC}$	-----	5°C/W

#### Power Dissipation, PD @ $T_A = 25^\circ\text{C}$

SOP-8L	-----	0.63W
PSOP-8L	-----	2W

- Note 1.** Stresses listed as the above "Absolute Maximum Ratings" may cause permanent damage to the device. These are for stress ratings. Functional operation of the device at these or any other conditions beyond those indicated in the operational sections of the specifications is not implied. Exposure to absolute maximum rating conditions for extended periods may remain possibility to affect device reliability.
- Note 2.** Devices are ESDsensitive. Handling precaution recommended.
- Note 3.**  $\theta_{JA}$  is measured in the natural convection at  $T_A = 25^\circ\text{C}$  on a high effective thermal conductivity test board of JEDEC 51-7 thermal measurement standard.
- Note 4.** The device is not guaranteed to function outside its operating conditions.

**Electrical Characteristics**

( $V_{CC} = 12V$ ,  $T_A = +25^{\circ}C$  unless otherwise specified.)

Parameter	Symbol	Test Conditions	Min	Typ	Max	Units
<b>Supply Input</b>						
Supply Voltage Range	$V_{CC}$		8	--	40	V
Supply Input Current	$I_{CCQ}$	COMP/EN = GND	-3	05	0A	m
	$I_{CC}$		-5		1A	m
<b>POWER-ON-RESET</b>						
$V_{CC}$ POR Threshold	$CCRTH$	$V_{CC}$ Rising.		78		V
$V_{CC}$ POR Threshold	$CCFTH$	$V_{CC}$ Falling		67		V
<b>OSCILLATOR</b>						
Normal PWM Frequency	OSC		-0	12	-z	KH
		$T_A = -25^{\circ}C$ to $80^{\circ}C$	10	-8	12	H
Minimum On-Time	ON-MIN		-0	20	-S	n
Duty Cycle Range	DUT			-0	9%	
<b>REFERENCE</b>						
Reference Voltage	REF		-2	1-	-V	
Reference Voltage Tolerance			-1	-1	+%	
$V_{REF}$ Load Compensator		$\Delta V_{ISEN} = 515mV$		2%		
<b>PWM ERROR AMPLIFIER</b>						
FB Input Current	FB	$V_{FB} = -1.2V$	-1	01		$\mu A$
COMP High Voltage	COMP_H		-5	5-	-V	
COMP Low Voltage	COMP_L		-8	0-	-V	
COMP Shutdown Threshold Voltage			-4	0-	-V	
COMP Source Current		$COMP = V_{COMP\_H} - 1V$	-2	4-	-A	$\mu$
COMP Sink Current		$COMP = -1V$	-2	4-	-A	$\mu$
<b>CURRENT SENSE AMPLIFIER</b>						
Difference Voltage between ISEN- and ISEN+	$\Delta V_{ISEN}$		-5	11	-V	m
<b>PROTECTION</b>						
FB Over Voltage Level	OVP	Percent of $V_{REF}$	-0	12	-%	
FB Under Voltage Level	UVP	Percent of $V_{REF}$		25		
Current Limit	LIM			45		
Over Temperature Shutdown			-0	16	-	$^{\circ}C$
Over Temperature Hysteresis			-0	4-	-	$^{\circ}C$
<b>Soft Start</b>						
Soft Start Time	TS					mS
Recycle Time				260		m

This page is intentionally left blank and will be updated later.

SOP-8L

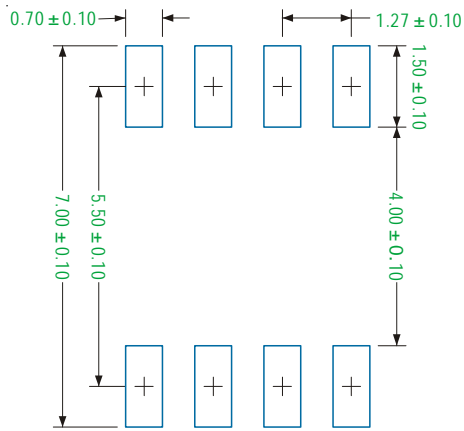

Recommended Solder Pad Layout

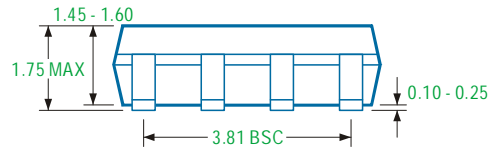
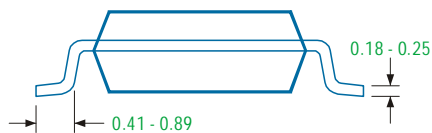
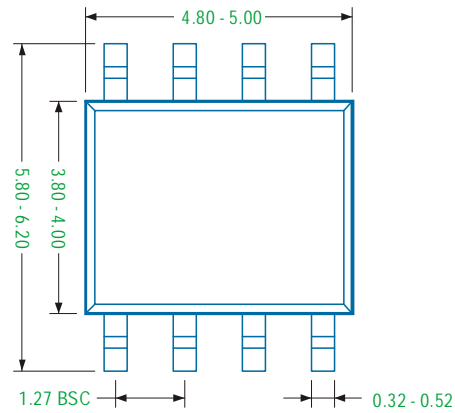

Note

1. Package Outline Unit Description:

BSC: Basic. Represents theoretical exact dimension or dimension target

MIN: Minimum dimension specified.

MAX: Maximum dimension specified.

REF: Reference. Represents dimension for reference use only This value is not a device specification.

TYP: Typical. Provided as a general value. This value is not a device specification.

2. Dimensions in Millimeters.

3. Drawing not to scale.

4. These dimensions do not include mold flash or protrusions. Mold flash or protrusions shall not exceed 0.15mm.

PSOP-8L

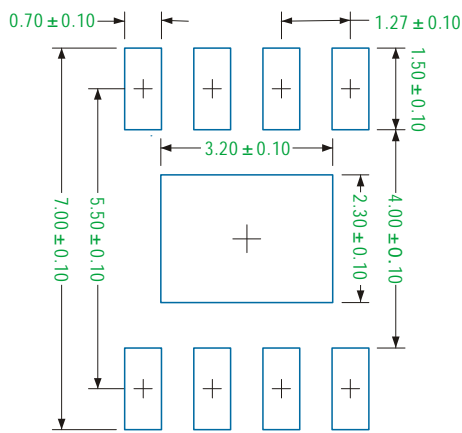

Recommended Solder Pad Layout

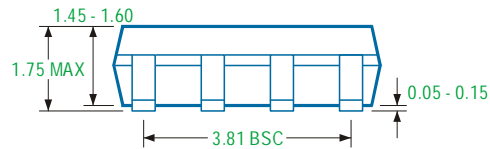
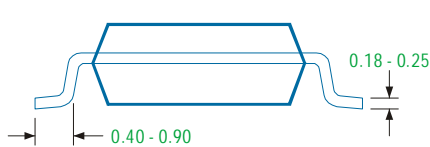
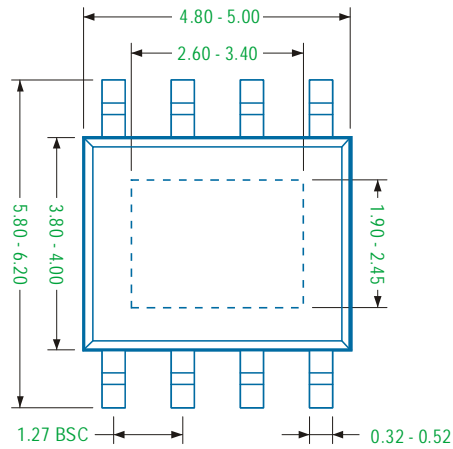

Note

1. Package Outline Unit Description:

BSC: Basic. Represents theoretical exact dimension or dimension target

MIN: Minimum dimension specified.

MAX: Maximum dimension specified.

REF: Reference. Represents dimension for reference use only This value is not a device specification.

TYP. Typical. Provided as a general value. This value is not a device specification.

2. Dimensions in Millimeters.

3. Drawing not to scale.

4. These dimensions do not include mold flash or protrusions. Mold flash or protrusions shall not exceed 0.15mm.