

NR111D

General Descriptions

The NR111D is buck regulator ICs integrates High-side power MOSFETs. The feature increasing efficiency at light loads allows the device to be used in the energy-saving applications. With the current mode control, ultra low ESR capacitors such as ceramic capacitors can be used. The ICs have protection functions such as Over-Current Protection (OCP), Under-Voltage Lockout (UVLO) and Thermal Shutdown (TSD). An adjustable Soft-Start by an external capacitor prevents the excessive inrush current at turn-on. The ICs integrate phase compensation circuit which reduces the number of external components and simplifies the design of customer application. The ON/OFF pin (EN Pin) turns the regulator on or off and helps to achieve low power consumption requirements. The NR111D is available in an 8-pin DIP package.

● DIP8 Package

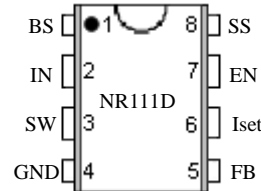
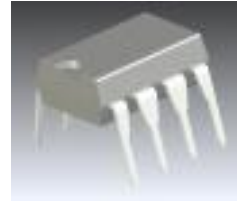

Features & Benefits

- Current mode PWM control
- Up to 94% Efficiency,
Up to 68% Efficiency at $I_O = 20\text{mA}$ Light Load
- Stable with low ESR ceramic output capacitors
- Built-in protection function
Over Current Protection (OCP)
Thermal Shutdown (TSD)
Under Voltage Lockout (UVLO)
- Built-in phase compensation
- Adjustable Soft-Start with an external capacitor
- Turn ON/OF the regulator function

Electrical Characteristics

- 4A output current
- Operating input range $V_{IN} = 6.5\text{V} \sim 31\text{V}$
- Output adjustable $V_O = 0.8\text{V} \sim 24\text{V}$
- Fixed 350kHz frequency

Applications

- LCD TV / Blu-Ray / Set top box
- Home appliance
- Green Electronic products
- Other power supply

Package

Typical Application Circuit

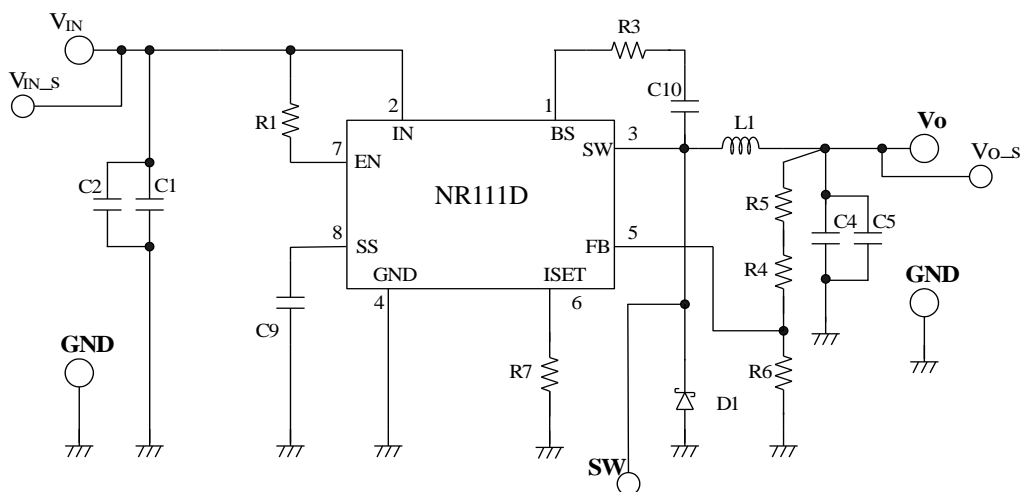

C1, C2: $10\ \mu\text{F} / 35\text{V}$
 C4, C5: $22\ \mu\text{F} / 16\text{V}$
 C9: $0.1\ \mu\text{F}$
 C10: $0.1\ \mu\text{F}$

R1: $1.7\text{M}\Omega$
 R3: 22Ω
 R4: $18\text{k}\Omega$, R5: $2.7\text{k}\Omega$ ($V_O = 5.0\text{V}$)
 R6: $3.9\text{k}\Omega$
 L1: $10\ \mu\text{H}$

NR111D

Oct./17/2013

Series Lineup

| Product No. | f _{sw} | V _{IN} | V _O | I _O |
|-------------|-----------------|--------------------------|----------------------------|----------------|
| NR111D | 350kHz | 8V to 31V ⁽¹⁾ | 0.8V to 24V ⁽²⁾ | 4A |

⁽¹⁾The minimum input voltage shall be either of 6.5V or V_O+3V, whichever is higher.

⁽²⁾The I/O condition is limited by the Minimum on-time (T_{ON(MIN)}).

Absolute Maximum Ratings

| 項目 | 記号 | 規格値 | 単位 | 条件 |
|--|--------------------|------------|------|---|
| DC input voltage | V _{IN} | 35 | V | |
| BS Pin voltage | V _{BS} | 44 | V | |
| BS-SW Pin voltage | V _{BS-SW} | 8 | V | |
| SW Pin voltage | V _{SW} | 35 | V | |
| FB Pin voltage | V _{FB} | 5.5 | V | |
| EN Pin voltage | V _{EN} | 35 | V | |
| SS Pin voltage | V _{SS} | 5.5 | V | |
| Power dissipation ⁽³⁾ | P _D | 1.47 | W | Glass-epoxy board mounting in a 70×60mm. (copper area in a 1310mm ²) Max T _J =150°C |
| Junction temperature ⁽⁴⁾ | T _J | -30 to 150 | °C | |
| Storage temperature | T _S | -40 to 150 | °C | |
| Thermal resistance (junction- Pin No. 7) | θ _{JP} | 41 | °C/W | |
| Thermal resistance (junction-ambient air) | θ _{JA} | 85 | °C/W | Glass-epoxy board mounting in a 70×60mm. (copper area in a 1310mm ²) |

⁽³⁾Limited by thermal shutdown.

⁽⁴⁾The temperature detection of thermal shutdown is about 160°C

Recommended Operating Conditions

| Parameter | Symbol | Ratings | | Units | Conditions |
|--|-----------------|-------------------|-----|-------|------------|
| | | MIN | MAX | | |
| DC input voltage ⁽⁵⁾ | V _{IN} | V _O +3 | 31 | V | |
| DC output current ⁽⁶⁾ ⁽⁷⁾ | I _O | 0 | 4.0 | A | |
| Output voltage | V _O | 0.8 | 24 | V | |
| Ambient operating temperature ⁽⁷⁾ | Top | -40 | 85 | °C | |

⁽⁵⁾The minimum value of input voltage is taken as the larger one of either 6.5V or V_O+3V.

⁽⁶⁾ Recommended circuit refer to Typical Application Circuit (P.7).

⁽⁷⁾To be used within the allowable package power dissipation characteristics (P.9)

Electrical Characteristics

Ta = 25°C

| Parameter | | Symbol | Ratings | | | Units | Test conditions |
|--|-------------------------------------|-------------------------------------|---------|-------|-------|-------|---|
| | | | MIN | TYP | MAX | | |
| Reference voltage | | V _{REF} | 0.784 | 0.800 | 0.816 | V | V _{IN} = 12V, I _O = 1.0A |
| Output voltage temperature coefficient | | $\Delta V_{REF}/\Delta T$ | — | ±0.05 | — | mV/°C | V _{IN} = 12V, I _O = 1.0A -40°C to +85°C |
| Switching frequency | | f _{SW} | 280 | 350 | 420 | kHz | V _{IN} = 12V, V _O = 5.0V, I _O = 1A |
| Line regulation | | ⁽⁸⁾ V _{Line} | — | 50 | — | mV | V _{IN} = 8V ~ 31V, V _O = 5.0V, I _O = 1A |
| Load regulation | | ⁽⁸⁾ V _{Load} | — | 50 | — | mV | V _{IN} = 12V, V _O = 5.0V, I _O = 0.1A ~ 2.0A |
| Overcurrent protection threshold | | I _{S1} | — | 1.5 | — | A | V _{IN} = 12V, V _O = 5.0V ISET = OPEN |
| | | I _{S2} | — | 5.5 | — | | V _{IN} = 12V, V _O = 5.0V ISET = SHORT |
| Supply Current | | I _{IN} | — | 1 | — | mA | V _{IN} = 12V V _{EN} = 10kΩ pull up to V _{IN} |
| Shutdown Supply Current | | I _{IN(off)} | 0 | 1 | — | μA | V _{IN} = 12V, I _O = 0A, V _{EN} = 0V |
| SS Pin | Source current at low level voltage | I _{EN/SS} | 6 | 10 | 14 | μA | V _{SS} = 0V, V _{IN} = 12V |
| EN Pin | Sink current | I _{EN} | | 20 | 50 | μA | V _{EN} = 10V |
| | Threshold voltage | V _{CEH} | 0.7 | 1.4 | 2.1 | V | V _{IN} = 12V |
| ISET Pin | Open voltage | V _{ISET} | | 1.5 | | V | V _{IN} = 12V |
| Max on-duty | | ⁽⁸⁾ D _{MAX} | — | 90 | — | % | |
| Minimum on-time | | ⁽⁸⁾ T _{ON(MIN)} | — | 150 | — | nsec | |
| Thermal shutdown threshold temperature | | ⁽⁸⁾ TSD | 151 | 165 | — | °C | |
| Thermal shutdown restart hysteresis of temperature | | ⁽⁸⁾ TSD_hys | — | 20 | — | °C | |

⁽⁸⁾ Guaranteed by design, not tested.

The input and output condition is limited by Minimum on-time.

NR111D

Typical characteristics

(1) Efficiency

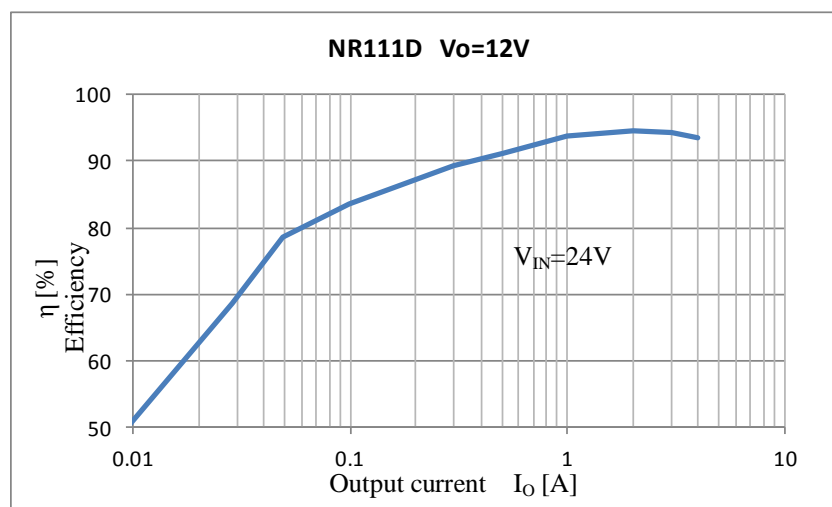
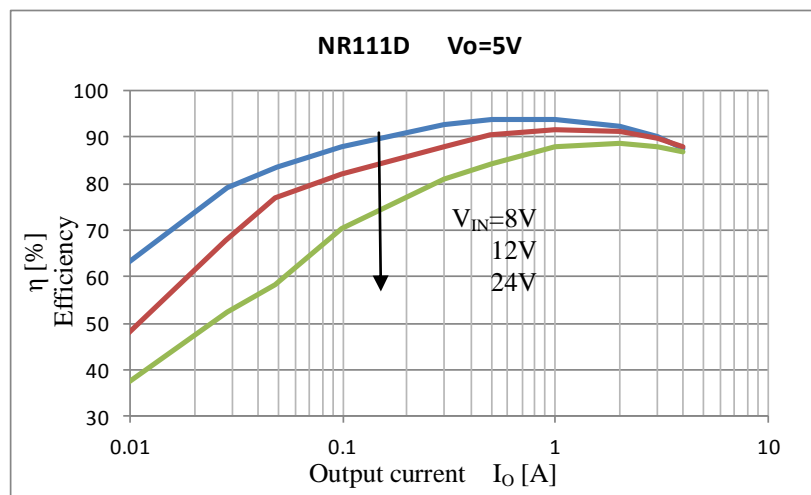
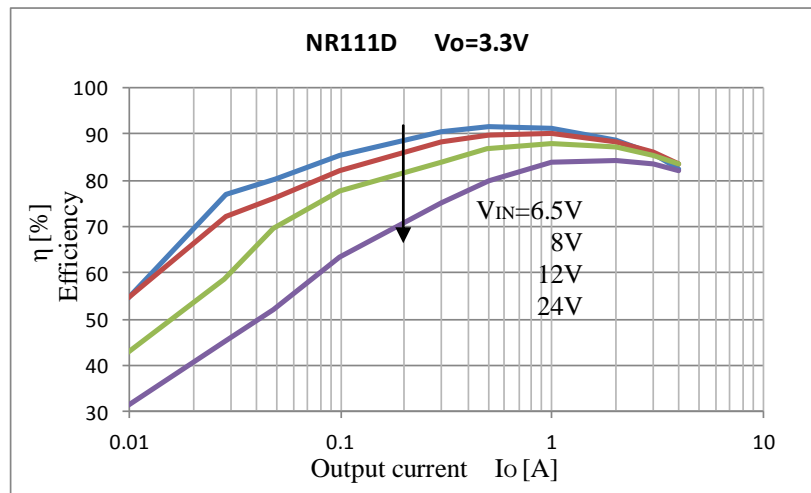

NR111D

(2) Output start-up Load=CR

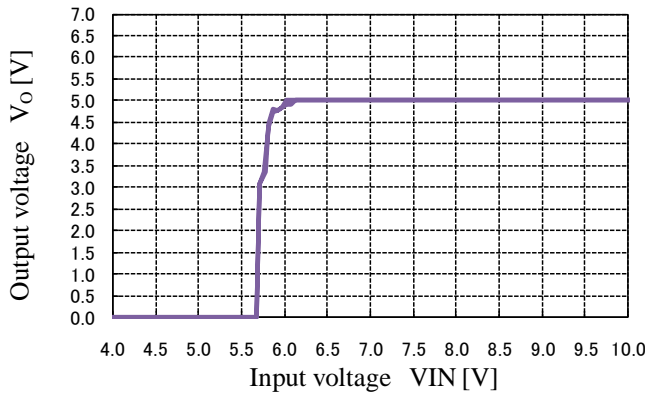

(5) Over current protection

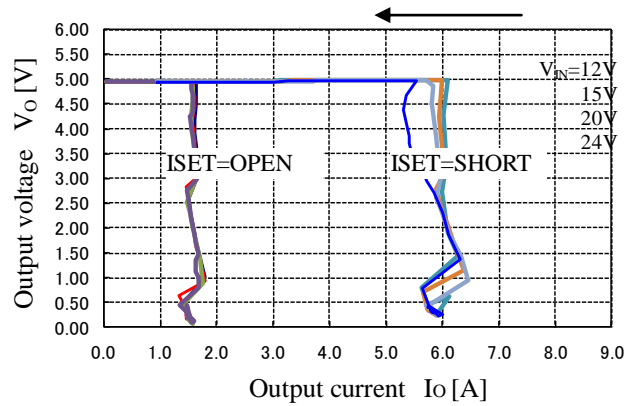

(3) Load Regulation : V_{Load}

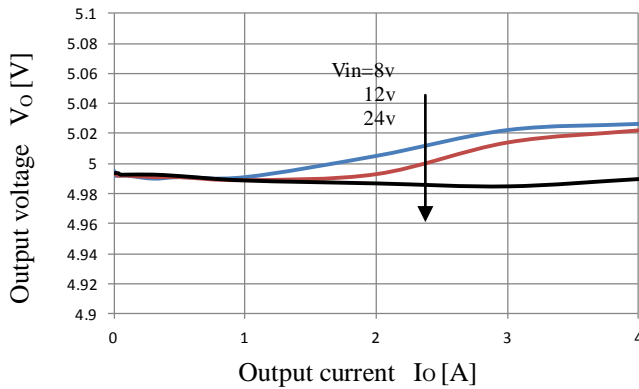

(6) Supply current : I_{IN}
At No-load $V_o = 5.0V$

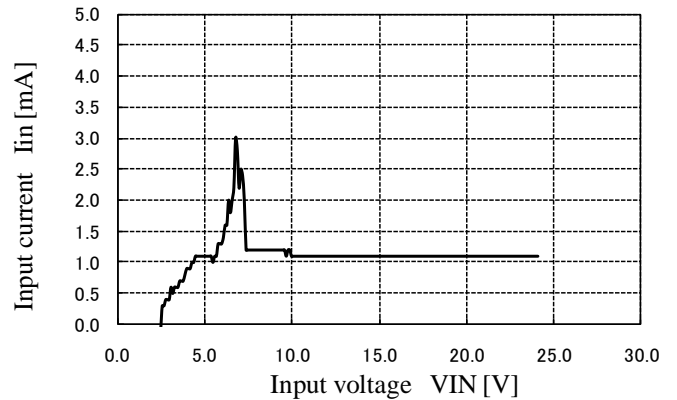

(4) Shut down supply current : $I_{IN(off)}$

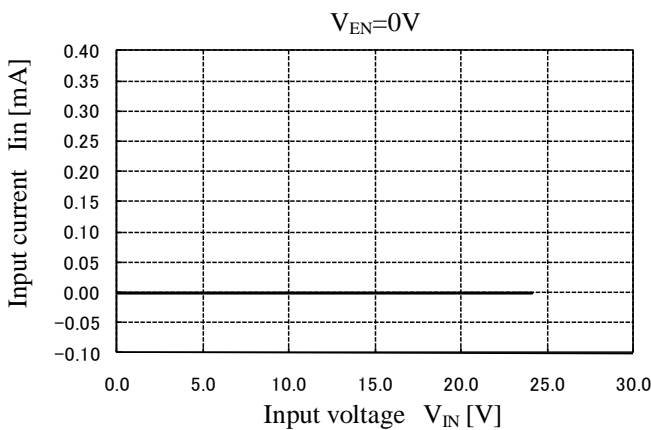

(7) Switching Frequency : fsw

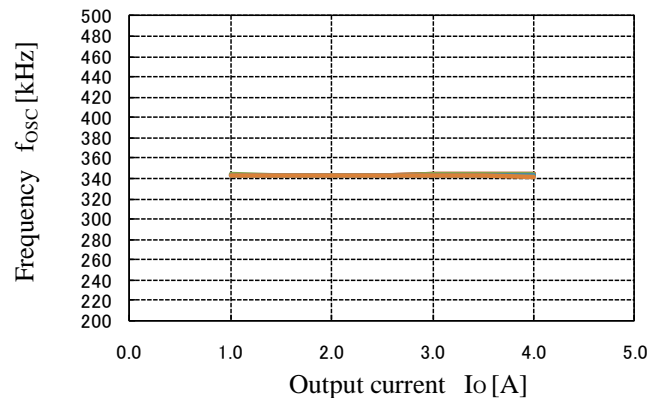

NR111D

Functional Block Diagram

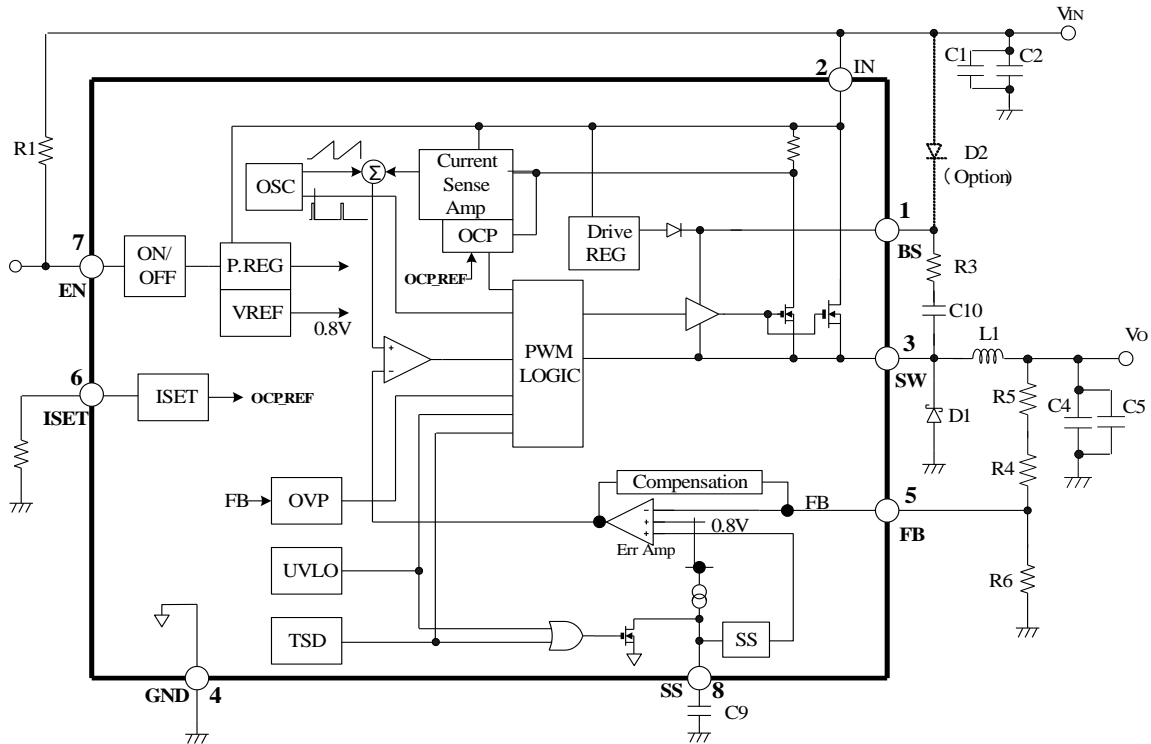

Pin Assignment & Functions

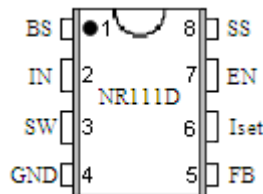

Pin Assign

Pin Assign & Functions

| Pin No. | Symbol | Description |
|---------|--------|--|
| 1 | BS | High-side Boost input. BS supplies the drive for High-side Nch-MOSFET switch. Connect a capacitor and a resistor between SW to BS. |
| 2 | IN | Power input. IN supplies the power to the IC as well as the regulator switches |
| 3 | SW | Power switching output. SW supplies power to the output. Connect the LC filter from SW to the output. Note that a capacitor is required from SW to BS to supply the power the High-side switch |
| 4 | GND | Ground. Connect the exposed pad to Pin No.4 |
| 5 | FB | Feedback input Pin to compare Reference Voltage. The feedback threshold is 0.8V. To set the output voltage, FB Pin is required to connect between resistive voltage divider R4 and R6. |
| 6 | Iset | Adjust Pin of OCP starting current. OCP starting current can be adjusted by connecting a resistor to ISET Pin. In the case of using at Maximum Io, ISET Pin is required to connect to GND. |
| 7 | EN | Enable input. Drive EN Pin high to turn on the regulator, low to turn it off. |
| 8 | SS | Soft-Start control input. To set the soft-start period, connect to a capacitor between GND. |

Example Application Circuit

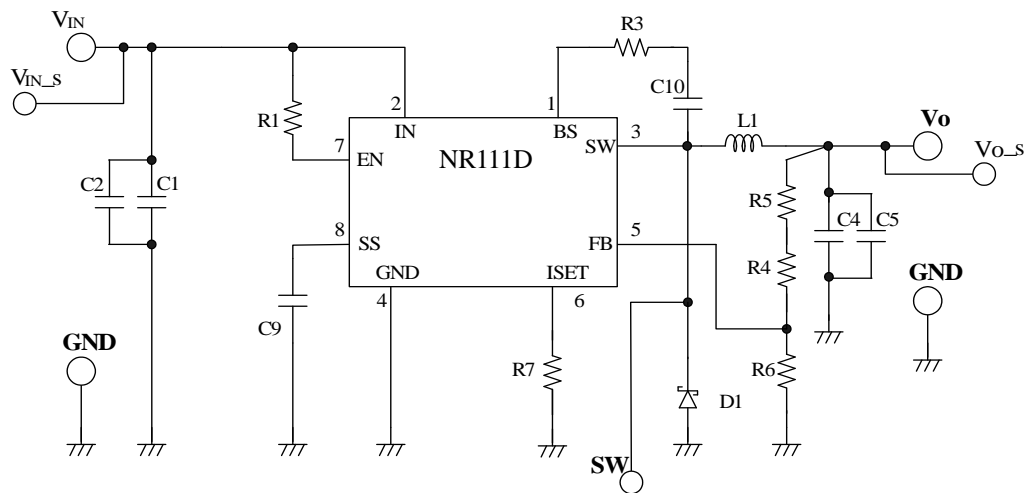
C1, C2: 10 μ F / 35VR1: 1.7M Ω L1: 10 μ HC4, C5: 22 μ F / 16VR3: 22 Ω C9: 0.1 μ FR4: 18k Ω , R5: 2.7k Ω ($V_o=5.0V$)C10: 0.1 μ FR6: 3.9k Ω

A design guide of External Components

(1)Diode D1

• The schottky-barrier diode must be used for D1. If other diodes like fast recovery diodes are used, IC may be destroyed because of the reverse voltage applied by the recovery voltage or ON voltage.

(2)Choke coil L1

• If the winding resistance of the choke coil is too high, the efficiency may go down to the extent that it is out of the rating.
 • As the start current of the over current protection is approximately 4A, attention must be paid to the heating of the choke coil by the magnetic saturation due to overload or short-circulated load.

(3)Capacitor C1(C2), C4(C5), C9

• As large ripple currents across C1 (C2) and C4 (C5), capacitors with high frequency and low impedance for SMPS must be used. Especially when the impedance of C4 (C5) is high, the switching waveform may not be normal at low temperature.
 • C9 is a capacitor for soft start. In case soft start function is not used, please keep Pin No.2 open.

(4)Resistor R4, R5,R6

• R4, R5, R6 are resistor to the Output Voltage. IADJ is required to set to 0.2mA.
 R4, R5, R6 are calculated by the equation (1).

$$R4 + R5 = \frac{(V_o - V_{FB})}{I_{FB}} = \frac{(V_o - 0.8)}{0.2 \times 10^{-3}} (\Omega), \quad R6 = \frac{V_{FB}}{I_{FB}} = \frac{0.8}{0.2 \times 10^{-3}} \doteq 4.0k(\Omega) \quad \text{----- (1)}$$

I_{FB}:The electric current which flows to R6

NR111D

Oct./17/2013

(5) Resistor R7

- R7 is resistor to adjust OCP starting current .

The graph shows the relationship between R7 and OCP .

The OCP output current is calculated in terms of the equation (2),(3),(4).

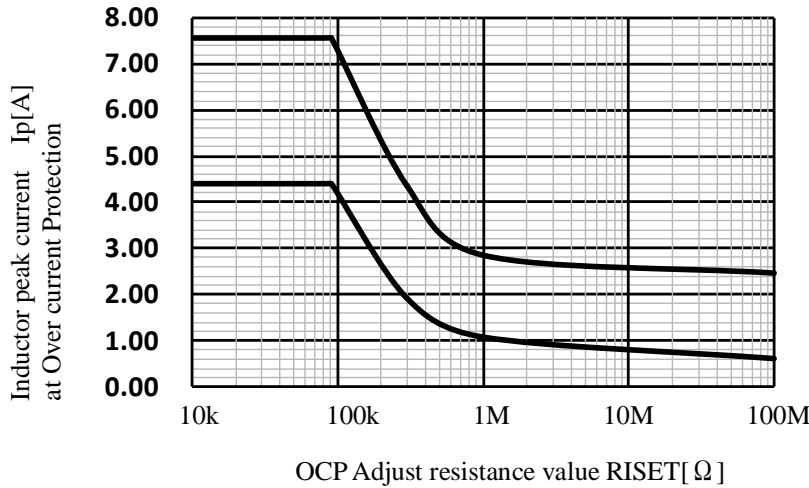

VIN: Input voltage
 Vo: Output voltage
 Io: Output current
 L: Inductance
 f: Switching Frequency
 ΔI_L : Inductor ripple current
 Ip: Inductor peak current at Over current protection

*Ip becomes the peak value of inductor ripple current. Calculate it in accordance with the following equation.

In case of continuous inductor current...
$$\Delta I_L = I_p - \frac{\Delta I_L}{2} \quad \text{----- (2)}$$

In case of discontinuous inductor current...
$$I_o = \frac{(V_{IN} \times L \times f)}{\{2 \times V_o \times (V_{IN} - V_o)\}} \times I_p^2 = \frac{1}{(2 \times \Delta I_L)} \times I_p^2 \quad \text{----- (3)}$$

*Inductor ripple current ...
$$\Delta I_L = \frac{V_o}{L \times f} \times \left(1 - \frac{V_o}{V_{IN}}\right) \quad \text{----- (4)}$$

In order to have optimum operating condition, each component must be connected with the minimum distance.

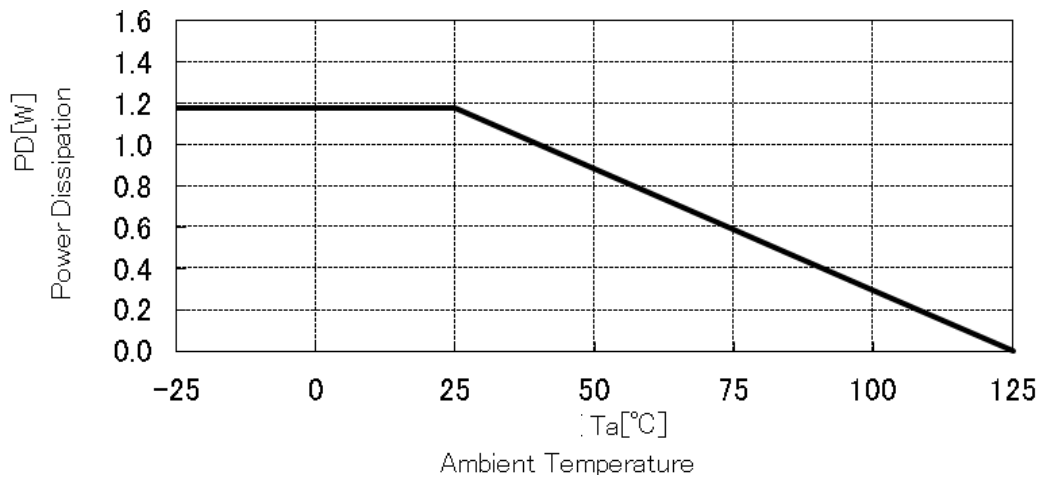
Allowable package power dissipation**NOTES:**

- 1) Glass-epoxy board mounting in a 30×30mm
- 2) copper area : 25×25mm
- 3) The power dissipation is calculated at the junction temperature 125 °C
- 4) Losses can be calculated by the following equation.
As the efficiency is subject to the input voltage and output current, it shall be obtained from the efficiency curve and substituted in percent
- 5) Thermal design for D1 shall be made separately.

$$P_D = V_O \cdot I_O \left(\frac{100}{\eta_x} - 1 \right) - V_F \cdot I_O \left(1 - \frac{V_O}{V_{IN}} \right)$$

V_O : Output voltage

V_{IN} : Input voltage

I_O : Output current

η_x : Efficiency(%)

V_F : Diode forward voltage
SJPB-L4···0.55V($I_O=3A$)

NR111D

PCB layout recommendation

*The demonstration Printed circuit board. It can mount a part for the experiment ,except for the Example Application Circuit.

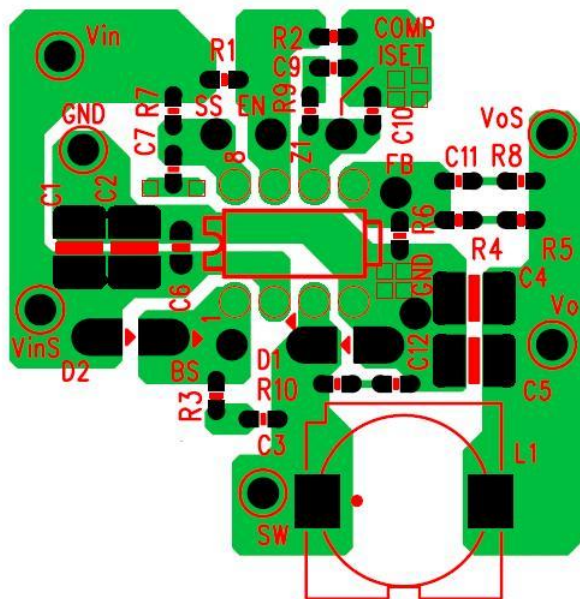

Front Side: Component Side (double sided board)

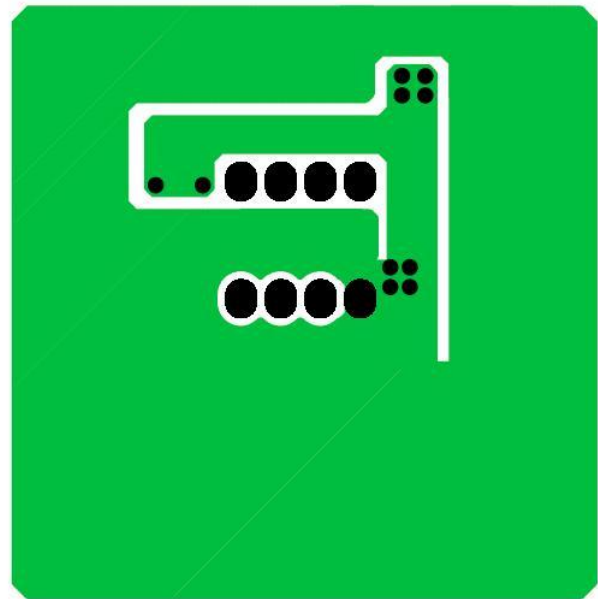

Back Side: GND Side (double sided board)

Note

- 1) Size of the PCB is about 40mm × 40mm
- 2) Dimension is in millimeters, dimension in bracket is in inches.
- 3) Drawing is not to scale.

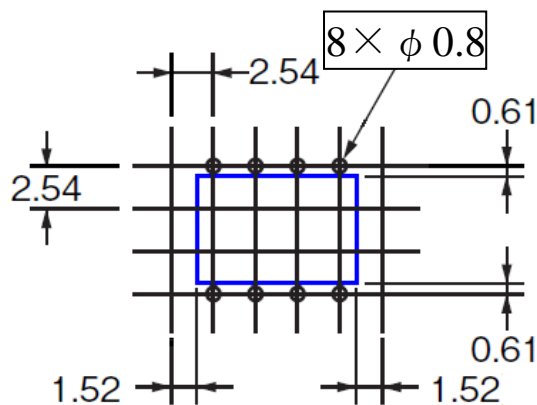

(Reference)
DIP8 package
About the position of the lead-insertion hole

NR111D

Oct./17/2013

Package outline & Dimension

An outside size is supplied by either Package type A or Package type B.

Package A

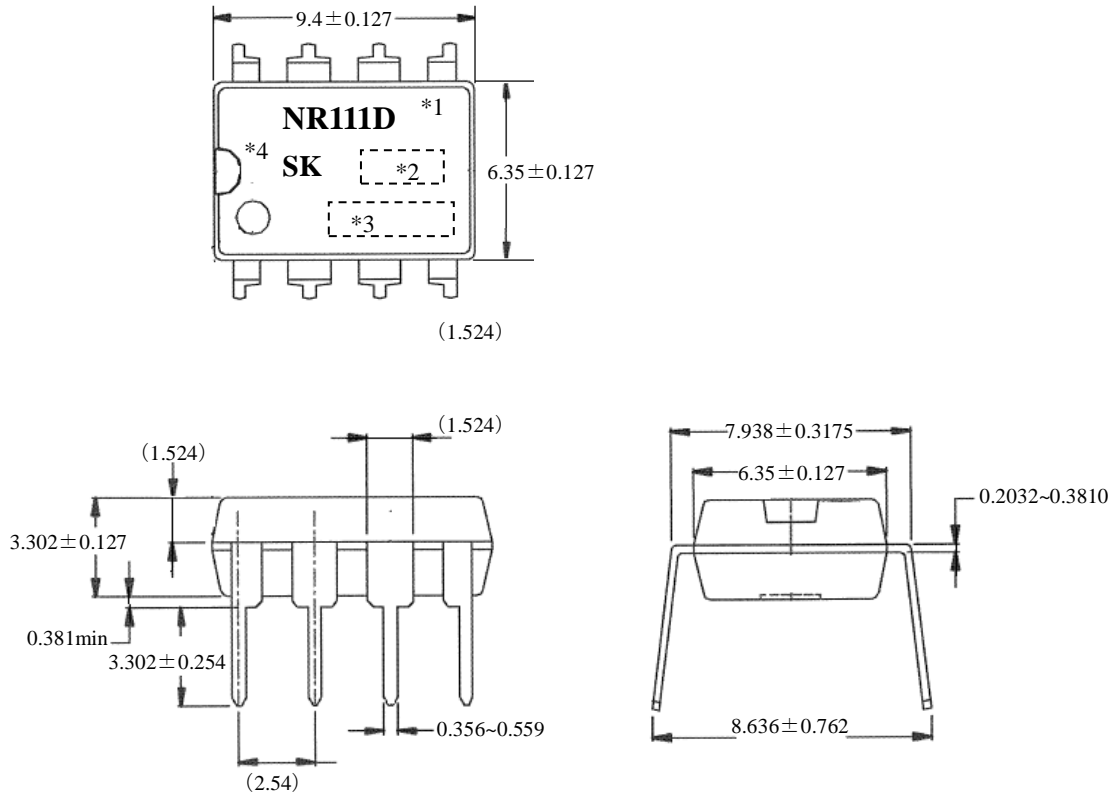

PIN Assignment

- 1.NC
- 2.IN
- 3.SW
- 4.GND
- 5.FB
- 6.EN
- 7.SS
- 8.BS

Marking

- *1. Type number
- *2. Lot number (three digit)
 - 1st letter: The last digit of year
 - 2nd letter: Month
(1 to 9 for Jan. to Sept.,
O for Oct. N for Nov. D for Dec.)
 - 3rd letter week
 - 01~03 : Arabic Numerical
- *3. Control number (four digit)
- *4 .Logo: SK

Note:

- 1) Dimension is in millimeters.
- 2) Drawing is not to scale.

NR111D

Oct./17/2013

Package B

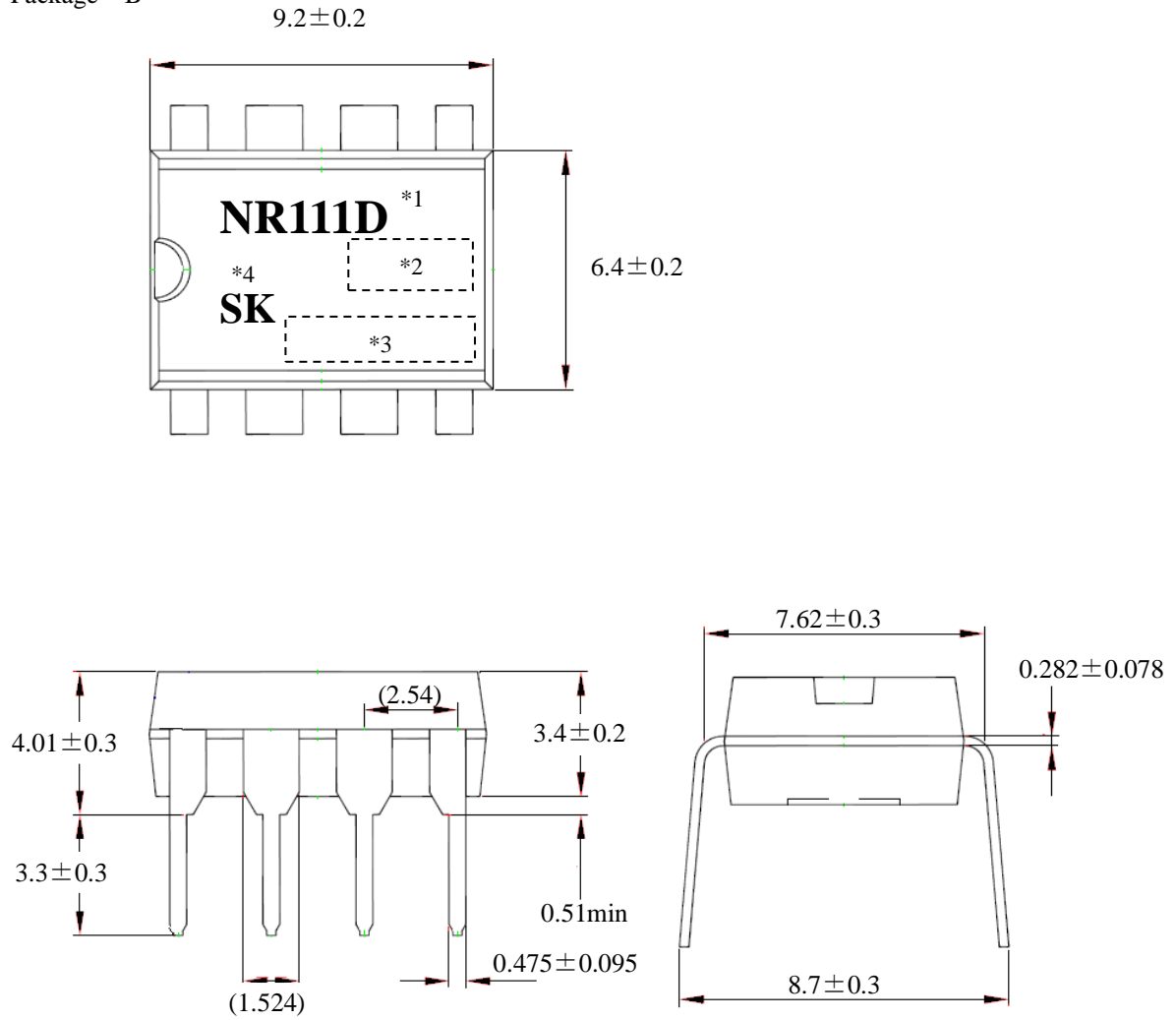

PIN Assignment

- 1.NC
- 2.IN
- 3.SW
- 4.GND
- 5.FB
- 6.EN
- 7.SS
- 8.BS

Note:

- 1) Dimension is in millimeters.
- 2) Drawing is not to scale.

Marking

- *1. Type number
- *2. Lot number (three digit)
 - 1st letter: The last digit of year
 - 2nd letter: Month
(1 to 9 for Jan. to Sept.,
O for Oct. N for Nov. D for Dec.)
 - 3rd letter week

01~03 : Arabic Numerical
- *3. Control number (four digit)
- *4 .Logo: SK

OPERATING PRECAUTIONS

Reliability can be affected adversely by improper storage environments and handling methods. Please observe the following cautions.

Heat dissipation and reliability

Thermal performance of the surface mount package IC depends on the material and area size of PCB and its copper plane. Design thermal condition with sufficient margin

Parallel operation

The parallel operation to increase the current is not available.

Thermal shut down

The NR111D has a thermal protection circuit.

This circuit protects the IC from the heat generation by the over load.

This circuit cannot guarantee the long-term reliability against the continuously over load status.

Cautions for Storage

- Ensure that storage conditions comply with the standard temperature (5 to 35°C) and the standard relative humidity (around 40 to 75%); avoid storage locations that experience extreme changes in temperature or humidity.
- Avoid locations where dust or harmful gases are present and avoid direct sunlight.
- Reinspect for rust on leads and solderability of products that have been stored for a long time.

Cautions for Testing and Handling

- When tests are carried out during inspection testing and other standard test periods, protect the products from power surges from the testing products, shorts between the product pins, and wrong connections. In addition, avoid tests exceeded ratings

Soldering

When soldering the products, please be sure to minimize the working time, within the following limits.

- Reflow Preheat ; 180°C / 90±30s
Heat ; 250°C / 10±1s (260°C peak ,2times)
- Soldering iron ; 380±10°C / 3.5±0.5s (1time)

Electrostatic Discharge

- When handling the products, the operator must be grounded. Grounded wrist straps worn should have at least 1MΩ of resistance from the operator to ground to prevent shock hazard, and it should be placed near the operator.
- Workbenches where the products are handled should be grounded and be provided with conductive table and floor mats.
- When using measuring equipment such as a curve tracer, the equipment should be grounded.
- When soldering the products, the head of a soldering irons or the solder bath must be grounded in order to prevent leak voltages generated by them from being applied to the products.
- The products should always be stored and transported in Sanken shipping containers or conductive containers, or be wrapped in aluminum foil.

IMPORTANT NOTES

- The contents in this document are subject to changes, for improvement and other purposes, without notice. Make sure that this is the latest revision of the document before use.
- Application and operation examples described in this document are quoted for the sole purpose of reference for the use of the products herein and Sanken can assume no responsibility for any infringement of industrial property rights, intellectual property rights or any other rights of Sanken or any third party which may result from its use.
- Although Sanken undertakes to enhance the quality and reliability of its products, the occurrence of failure and defect of semiconductor products at a certain rate is inevitable. Users of Sanken products are requested to take, at their own risk, preventative measures including safety design of the equipment or systems against any possible injury, death, fires or damages to the society due to device failure or malfunction.
- Sanken products listed in this document are designed and intended for the use as components in general purpose electronic equipment or apparatus (home appliances, office equipment, telecommunication equipment, measuring equipment, etc.).
When considering the use of Sanken products in the applications where higher reliability is required (transportation equipment and its control systems, traffic signal control systems or equipment, fire/crime alarm systems, various safety devices, etc.), please contact your nearest Sanken sales representative to discuss, prior to the use of the products herein.
The use of Sanken products without the written consent of Sanken in the applications where extremely high reliability is required (aerospace equipment, nuclear power control systems, life support systems, etc.) is strictly prohibited.
- In the case that you use Sanken semiconductor products or design your products by using Sanken semiconductor products, the reliability largely depends on the degree of derating to be made to the rated values. Derating may be interpreted as a case that an operation range is set by derating the load from each rated value or surge voltage or noise is considered for derating in order to assure or improve the reliability. In general, derating factors include electric stresses such as electric voltage, electric current, electric power etc., environmental stresses such as ambient temperature, humidity etc. and thermal stress caused due to self-heating of semiconductor products. For these stresses, instantaneous values, maximum values and minimum values must be taken into consideration.
In addition, it should be noted that since power devices or IC's including power devices have large self-heating value, the degree of derating of junction temperature affects the reliability significantly.
- When using the products specified herein by either (i) combining other products or materials therewith or (ii) physically, chemically or otherwise processing or treating the products, please duly consider all possible risks that may result from all such uses in advance and proceed therewith at your own responsibility.
- Anti radioactive ray design is not considered for the products listed herein.
- Sanken assumes no responsibility for any troubles, such as dropping products caused during transportation out of Sanken's distribution network.
- The contents in this document must not be transcribed or copied without Sanken's written consent.