



SANYO Semiconductors

DATA SHEET

An ON Semiconductor Company

LV5232VH — Bi-CMOS IC 16ch LED Driver

Overview

The LV5232VH is a semiconductor integrated circuit that incorporates a serial input and serial or parallel output 16-stage shift register that features a CMOS structure based on Bi-CMOS process technology. The LV5232VH also contains an n-channel CMOS construction high-withstand-voltage, large-current drive 16-stage parallel output driver. The protection circuit of the output malfunction is built into.

Features

- Serial input and serial or parallel output
- Serial output enables cascade connection
- Serial input/output levels compatible with typical CMOS devices
- High-withstand-voltage LED driver with open drain output
 - High withstand voltage ($V_{DS} < 42V$)
- Operating temperature range $T_a = -25$ to $75^\circ C$
- Output malfunction protection circuit
 - Reset input pin
- Enable input for output control
- Low supply current ($30\mu A$ typ. during standby $I_{CC} \leq 40\mu A$)
- High-current drive ($I_O \text{ max} = 100mA$)
- V_{CC} decrease voltage confirmation

Specifications

Maximum Ratings at $T_a = 25^\circ C$

Parameter	Symbol	Conditions	Ratings	Unit
Maximum supply voltage	$V_{CC \text{ max}}$	SV_{CC}	6	V
Output voltage	$V_O \text{ max}$	LEDO1 to LEDO16 off	42	V
Output current	$I_O \text{ max}$		100	mA
Allowable power dissipation	$P_d \text{ max}$	$T_a \leq 25^\circ C$ *	1100	mW
Operating temperature	T_{opr}		-25 to +75	$^\circ C$
Storage temperature	T_{stg}		-40 to +125	$^\circ C$

* Specified board : 114.3mm × 76.1mm × 1.6mm, glass epoxy board.

- Any and all SANYO Semiconductor Co.,Ltd. products described or contained herein are, with regard to "standard application", intended for the use as general electronics equipment (home appliances, AV equipment, communication device, office equipment, industrial equipment etc.). The products mentioned herein shall not be intended for use for any "special application" (medical equipment whose purpose is to sustain life, aerospace instrument, nuclear control device, burning appliances, transportation machine, traffic signal system, safety equipment etc.) that shall require extremely high level of reliability and can directly threaten human lives in case of failure or malfunction of the product or may cause harm to human bodies, nor shall they grant any guarantee thereof. If you should intend to use our products for applications outside the standard applications of our customer who is considering such use and/or outside the scope of our intended standard applications, please consult with us prior to the intended use. If there is no consultation or inquiry before the intended use, our customer shall be solely responsible for the use.
- Specifications of any and all SANYO Semiconductor Co.,Ltd. products described or contained herein stipulate the performance, characteristics, and functions of the described products in the independent state, and are not guarantees of the performance, characteristics, and functions of the described products as mounted in the customer's products or equipment. To verify symptoms and states that cannot be evaluated in an independent device, the customer should always evaluate and test devices mounted in the customer's products or equipment.

SANYO Semiconductor Co., Ltd.

<http://semicon.sanyo.com/en/network>

LV5232VH

Operating Conditions at $T_a = 25^\circ\text{C}$

Parameter	Symbol	Conditions	Ratings	Unit
Recommended supply voltage	V_{CC}	SV_{CC}	5.0	V
Operating supply voltage range	$V_{CC\ op}$	SV_{CC}	3.0 to 5.5	V
Output applied voltage	V_O		42	V
Output current	I_O	Duty = 45% to 55%	100	mA

Electrical Characteristics at $T_a = 25^\circ\text{C}$, $V_{CC} = 5.0\text{V}$

Parameter	Symbol	Conditions	Ratings			Unit
			min	typ	max	
Quiescent current drain	I_{CC1}	LEDO driver off (standby)		30	40	μA
LEDO output on resistance	R_{on}	$I_O = 30\text{mA}$		5		Ω
OFF leak current	I_{leak}	$V_O = 42\text{V}$		0	10	μA
Driver output malfunction prevention voltage	V_t		2.58	2.70	2.82	V
Control circuit block						
H level 1	V_{INH1}	Input H level	$V_{CC} \times 0.8$			V
L level 1	V_{INL1}	Input L level	0		$V_{CC} \times 0.2$	V
H level 2	V_{OUTH1}	SOUT $I_O = -1\text{mA}$	$V_{CC} - 0.3$			V
L level 2	V_{OUTL1}	SOUT $I_O = 1\text{mA}$	0		0.3	V

Package Dimensions

unit : mm (typ)

3222A

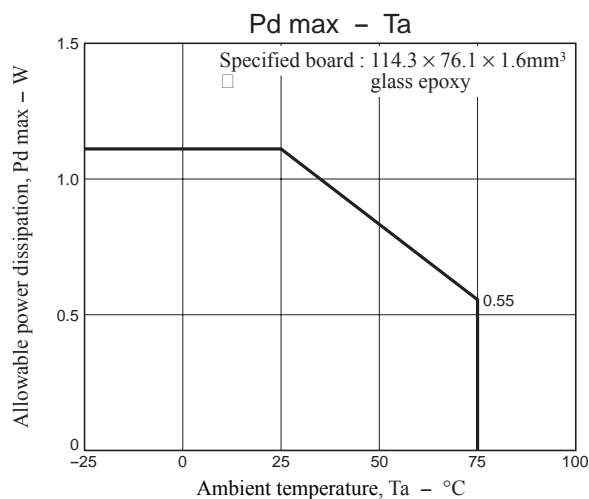
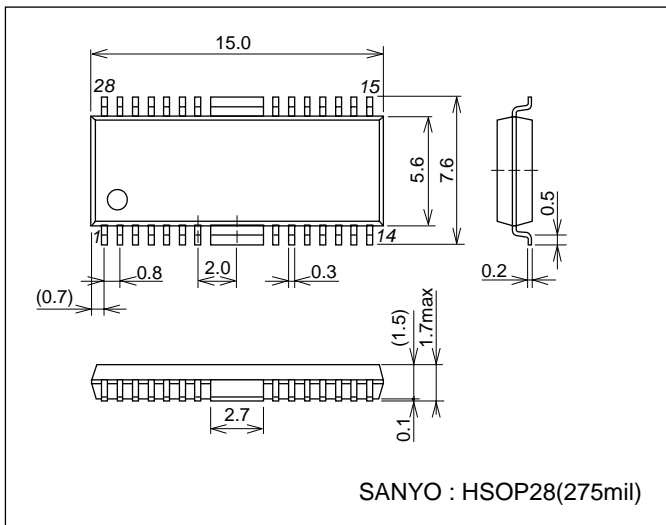

LV5232VH

Pin Assignment

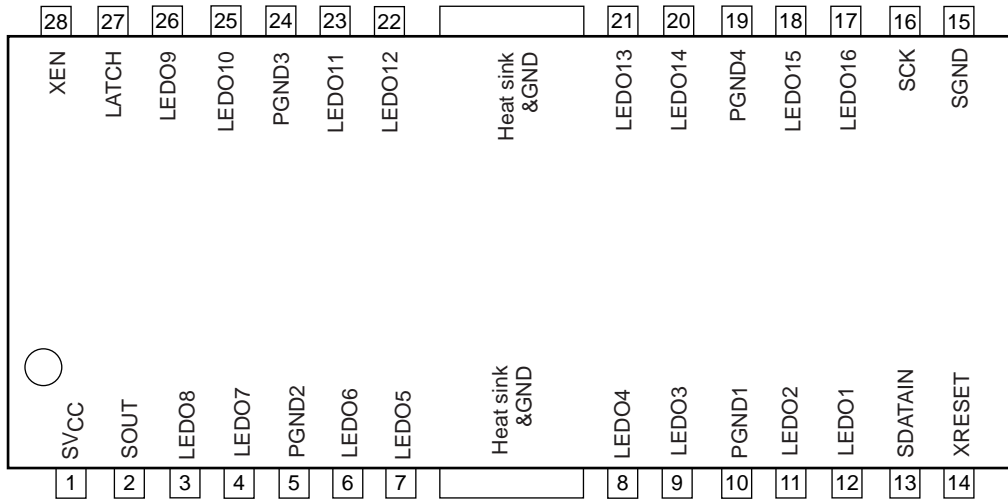

Top view

Pin Descriptions

Pin No.	Pin name	I/O	Description
1	SVCC		Power supply
2	SOUT	O	shift register output (final-stage shift register)
3	LEDO8	O	LEDO8 Latch output (LEDO8 of shift register)
4	LEDO7	O	LEDO7 Latch output (LEDO7 of shift register)
5	PGND2		GND
6	LEDO6	O	LEDO6 Latch output (LEDO6 of shift register)
7	LEDO5	O	LEDO5 Latch output (LEDO5 of shift register)
	Heat sink		
8	LEDO4	O	LEDO4 Latch output (LEDO4 of shift register)
9	LEDO3	O	LEDO3 Latch output (LEDO3 of shift register)
10	PGND1		GND
11	LEDO2	O	LEDO2 Latch output (LEDO2 of shift register)
12	LEDO1	O	LEDO1 Latch output (LEDO1 of shift register)
13	SDATAIN	I	Serial Input
14	XRESET	I	Reset input (shift register and latch)
15	SGND		GND
16	SCK	I	Clock input (for shift register)
17	LEDO16	O	LEDO16 Latch output (LEDO16 of shift register)
18	LEDO15	O	LEDO15 Latch output (LEDO15 of shift register)
19	PGND4		GND
20	LEDO14	O	LEDO14 Latch output (LEDO14 of shift register)
21	LEDO13	O	LEDO13 Latch output (LEDO13 of shift register)
	Heat sink		
22	LEDO12	O	LEDO12 Latch output (LEDO12 of shift register)
23	LEDO11	O	LEDO11 Latch output (LEDO11 of shift register)
24	PGND3		GND
25	PGND10	O	LEDO10 Latch output (LEDO10 of shift register)
26	PGND9	O	LEDO9 Latch output (LEDO9 of shift register)
27	LATCH	I	Latch input When the latch input is held low, the LED0 output status is retained. When a high-level is input, the LED0 outputs change when the status of the shift register changes.
28	XEN	I	Enable inputs (LEDO1 to LEDO16) When a high-level is input, all the LED0 outputs are turned off. When a low-level is input, the shift register data is output to LED0.

Block Diagram

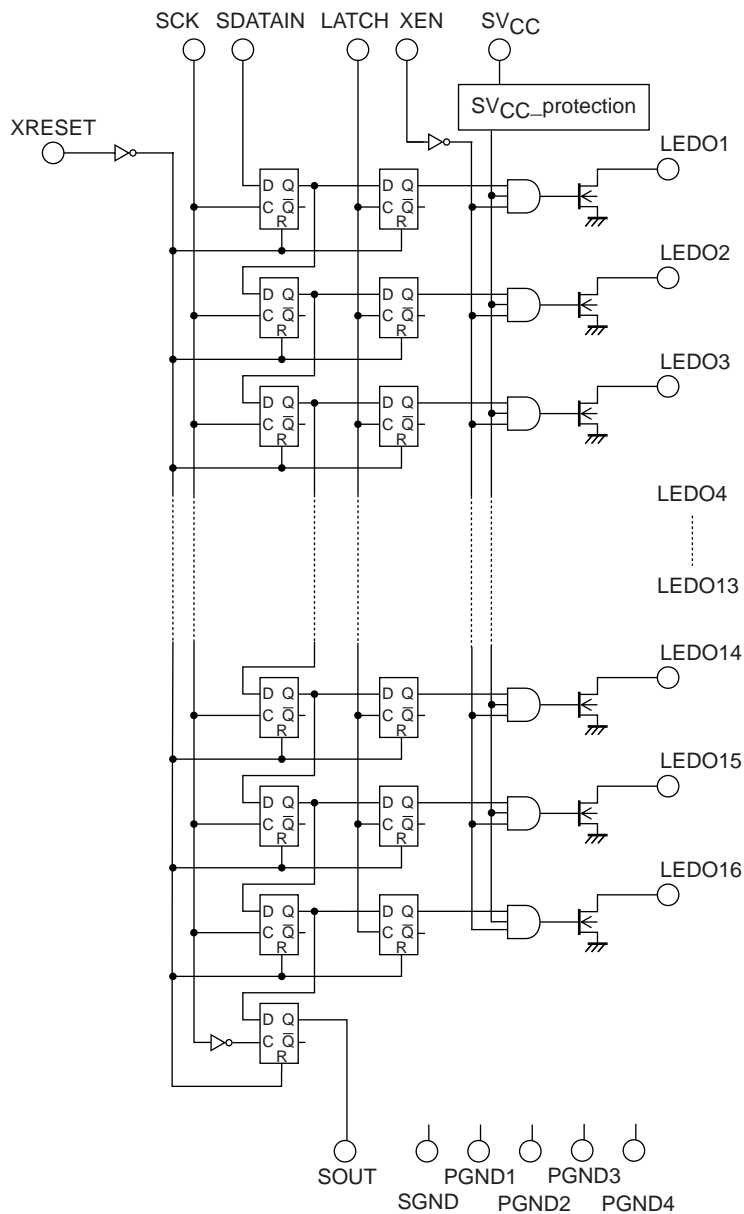

Function

The LV5232VH consists of 1) an 16-stage D-type flip-flop and 2) an 16-stage D-type flip-flop connected to the output of 1). When data is supplied to the serial data input (SDATAIN) and the clock pulse is supplied to the clock input (SCK), the serial data input signal is input to the internal shift register and the data already in the shift register shifted sequentially when the clock changes from low to high.

The serial output (SOUT) is used to connect multiple LV5232VH to expand the number of bits and is connected to the SDATAIN of the next stage. (Cascade connection supported.)

For parallel output, when the output control enable input (XEN) is low, the latch input (LATCH) changes from low to high and the clock pulse input changes from low to high, the serial data input signal is output to LEDO1, and the output is shifted sequentially. For parallel outputs (LED2 to LED16), the signals whose polarities inverted from those of the serial data input (SDATAIN) are output.

When the EN input is high, outputs LEDO1 through LEDO1 all turn off.

When the reset input is low, outputs LEDO1 through LED16 and SOUT outputs all turn off. The power must be turned on after checking that the reset input is low.

To prevent the malfunction, the output load protection circuit is built into. The output of LEDO1 to LEDO16 is compulsorily turned off when becoming below the voltage with a constant there is VCC.

LV5232VH

Pin Functions

Pin No.	Pin Name	Pin function	Equivalent Circuit
13 16	SDATAIN SCK	Pull-down input	
14 27 28	XRESET LATCH XEN	Pull-up input	
2	SOUT	SOUT output	
3 4 6 7 8 9 11 12 17 18 20 21 22 23 25 26	LEDO8 LEDO7 LEDO6 LEDO5 LEDO4 LEDO3 LEDO2 LEDO1 LEDO16 LEDO15 LEDO14 LEDO13 LEDO12 LEDO11 LEDO10 LEDO9	LEDO outputs LEDO1 to LEDO16	

LV5232VH

Timing conditions

Parameter	symbol	Conditions	min	typ	max	unit
Clock frequency	fs1	SCK Duty = 50%			10	MHz
Clock pulse width	twck	SCK	50			ns
Latch pulse width	twla	LATCH	50			ns
Data set up time	ts1	SDATAIN setup time relative to the rise of SCK	25			ns
Data hold time	th1	SDATAIN data hold time relative to the rise of SCK	25			ns
Clock latch time	tla1		100			ns
Input conditions 1	ton	SCK and SDATAIN rise time			100	ns
Input conditions 2	toff	SCL and SDATAIN fall time			100	ns

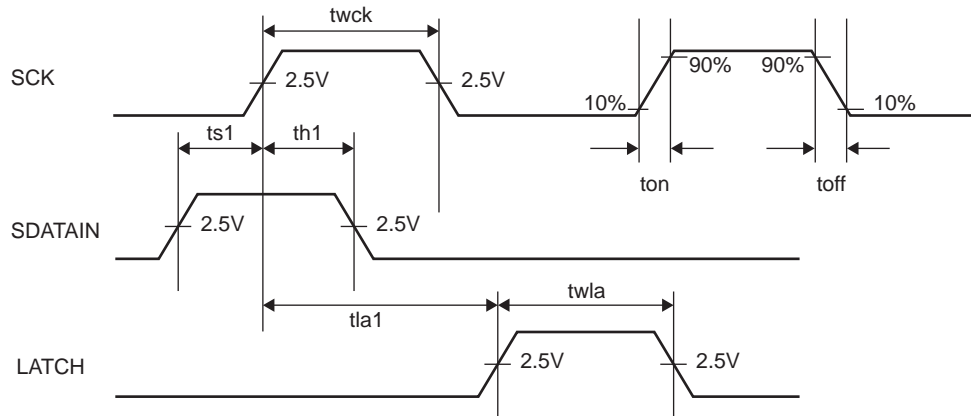

SOUT output timings

Parameter	symbol	Conditions	min	typ	max	unit
SOUT delay time 1	tdso1	The time from a SCK falling edge to SOUT rising edge			50	MHz
SOUT delay time 2	tdso2	The time from a SCK falling edge to SOUT falling edge			50	ns

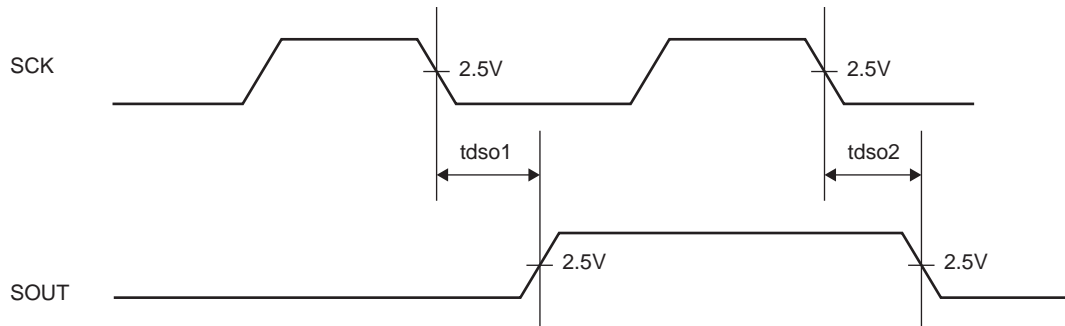

LV5232VH

LEDO output timings

Parameter	symbol	Conditions	min	typ	max	unit
LEDO delay time 1	tdled1	The time from an XEN rising edge to LEDO rising edge CL = 30pF, I _O = 100mA, V _O = 42V		100		ns
LEDO delay time 2	tdled2	The time from an XEN falling edge to LEDO falling edge CL = 30pF, I _O = 100mA, V _O = 42V		100		ns
LEDO rise time	trled	LEDO rise time CL = 30pF, I _O = 100mA, V _O = 42V		200		ns
LEDO fall time	tfled	LEDO fall time CL = 30pF, I _O = 100mA, V _O = 42V		200		ns
LEDO delay time 3	tdled3	The time from a LATCH rising edge to LEDO falling edge CL = 30pF, I _O = 100mA, V _O = 42V		200		ns

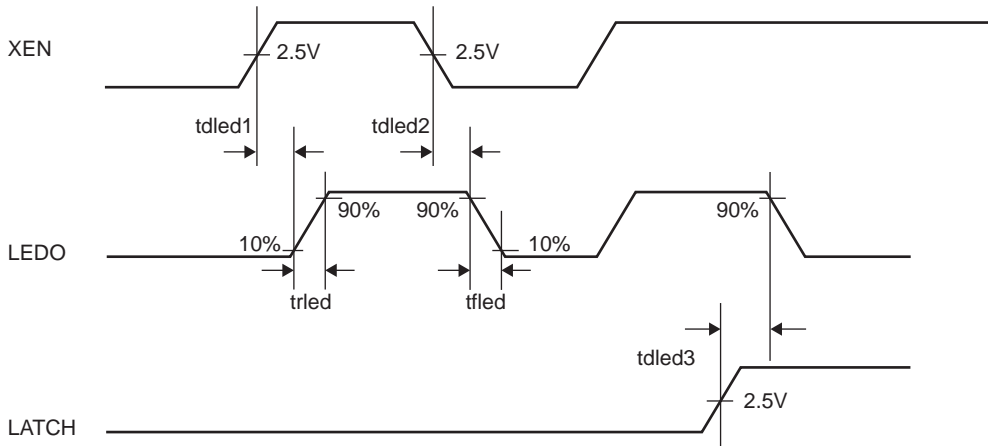

Application Circuit Example

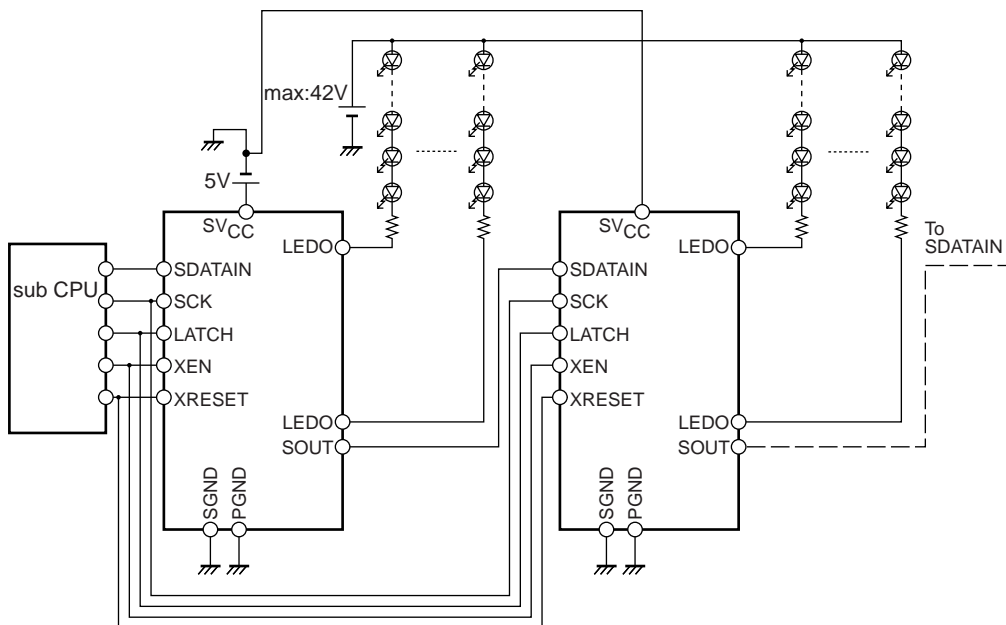

LV5232VH

Allowable output current characteristics

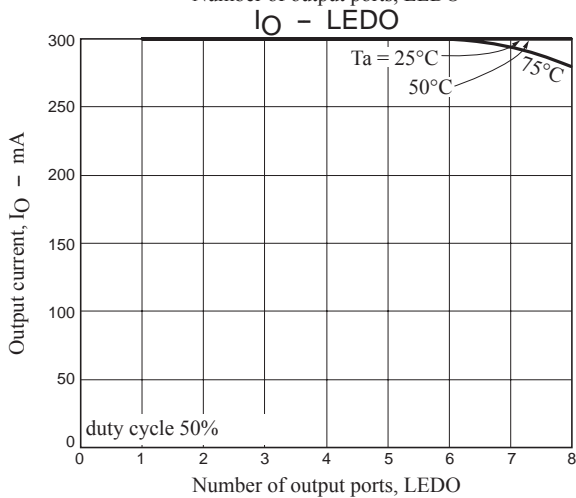
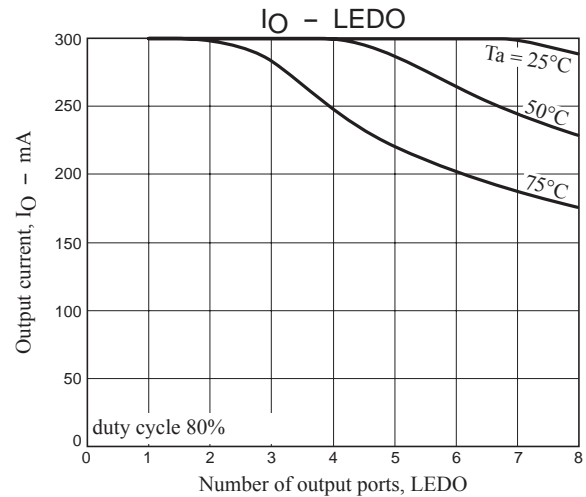
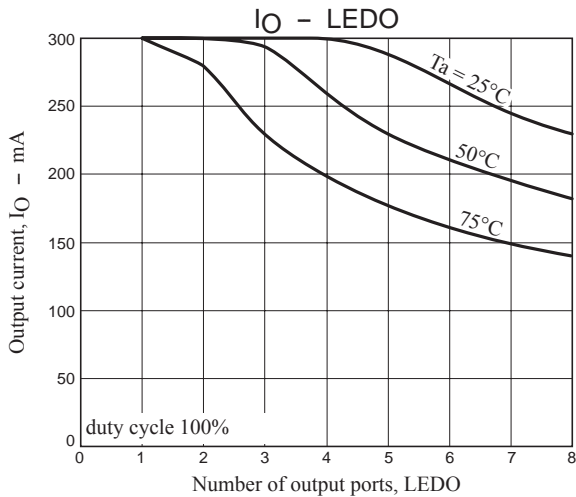

- SANYO Semiconductor Co.,Ltd. assumes no responsibility for equipment failures that result from using products at values that exceed, even momentarily, rated values (such as maximum ratings, operating condition ranges, or other parameters) listed in products specifications of any and all SANYO Semiconductor Co.,Ltd. products described or contained herein.
- SANYO Semiconductor Co.,Ltd. strives to supply high-quality high-reliability products, however, any and all semiconductor products fail or malfunction with some probability. It is possible that these probabilistic failures or malfunction could give rise to accidents or events that could endanger human lives, trouble that could give rise to smoke or fire, or accidents that could cause damage to other property. When designing equipment, adopt safety measures so that these kinds of accidents or events cannot occur. Such measures include but are not limited to protective circuits and error prevention circuits for safe design, redundant design, and structural design.
- In the event that any or all SANYO Semiconductor Co.,Ltd. products described or contained herein are controlled under any of applicable local export control laws and regulations, such products may require the export license from the authorities concerned in accordance with the above law.
- No part of this publication may be reproduced or transmitted in any form or by any means, electronic or mechanical, including photocopying and recording, or any information storage or retrieval system, or otherwise, without the prior written consent of SANYO Semiconductor Co.,Ltd.
- Any and all information described or contained herein are subject to change without notice due to product/technology improvement, etc. When designing equipment, refer to the "Delivery Specification" for the SANYO Semiconductor Co.,Ltd. product that you intend to use.
- Information (including circuit diagrams and circuit parameters) herein is for example only; it is not guaranteed for volume production.
- Upon using the technical information or products described herein, neither warranty nor license shall be granted with regard to intellectual property rights or any other rights of SANYO Semiconductor Co.,Ltd. or any third party. SANYO Semiconductor Co.,Ltd. shall not be liable for any claim or suits with regard to a third party's intellectual property rights which has resulted from the use of the technical information and products mentioned above.

This catalog provides information as of April, 2011. Specifications and information herein are subject to change without notice.