

Installation and service manual

Escon PD5710/PD5715/PD5720/ PD5730

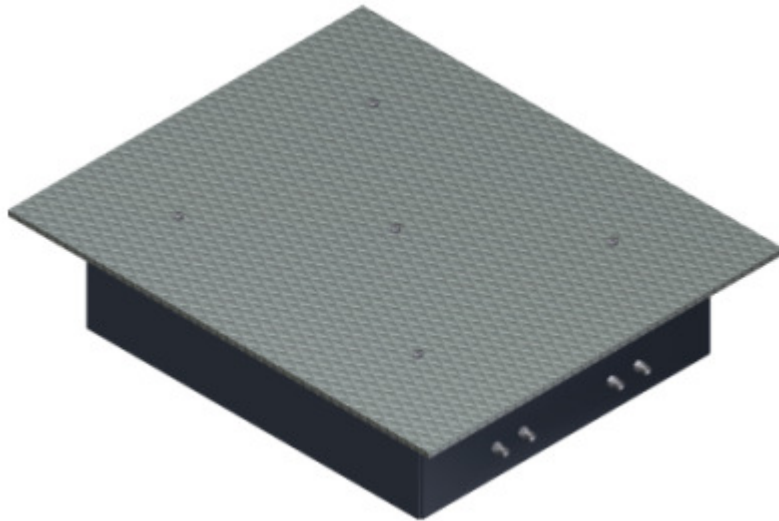

version 1.0
document number 314056
3/20/2013

ESCON®

Copyright

Copyright © 2013 Altus-Escon-Company B.V.. All rights reserved worldwide.

All of the information in this manual and any drawings and technical descriptions which have been made available by us, remain our property and may not, without first obtaining written permission from Altus-Escon-Company B.V., be used (except for operating the machine), duplicated in any way, handed over or made known to a third party.

Disclaimer

All efforts have been made to ensure the accuracy of this manual. However, should any errors be detected, Altus-Escon-Company B.V. would greatly appreciate being informed of them. The above notwithstanding, Altus-Escon-Company B.V. cannot assume any responsibility for any errors in this manual or their consequences.

The information contained in this document is subject to change without notice and does not represent a commitment on the part of the copyright holder. The software, associated hardware and documents are furnished under license agreement. The software, associated hardware and documents may be used only in accordance with the terms of that agreement.

Altus-Escon-Company B.V. contact details

The manufacturer of the Escon PD5710/PD5715/PD5720/PD5730 is Altus-Escon-Company B.V.. The manufacturer can be contacted at:

Altus-Escon-Company B.V.

Drachmeweg 26

2153 PA Nieuw Vennepe

The Netherlands

Phone: +31(0)88 258 37 00

Fax: +31(0)88 258 37 90

Website: www.altus-escon.com

E-mail: sales@altus-escon.com

CE Regulation Compliance

The product complies with all applicable CE directives.

Contents

- Chapter 1 About this manual 5**
 - Audience..... 5
 - Scope 5
 - Organization 6
 - Lay-out conventions..... 6
 - Related documents..... 7
- Chapter 2 Introduction 9**
 - The play detector 9
- Chapter 3 Safety 11**
 - General safety instructions..... 11
 - Safety around hydraulic systems 12
 - Safety for maintenance 12
 - System safety features 12
 - Lockout procedure: maintenance safety..... 13
 - Locking the play detector at the start of maintenance..... 13
 - Unlocking the play detector after maintenance 13
- Chapter 4 Specifications..... 15**
- Chapter 5 Functional description..... 17**
 - System overview..... 17
 - Floor unit..... 18
 - Control lamp PD5710..... 19
 - Control lamp PD5715..... 20
 - Control lamp PD5720..... 22
 - Control lamp PD5730..... 24
 - Hydraulic control unit 25
- Chapter 6 Transport and Installation 27**
 - Transport and hoisting 27
 - Storage..... 27
 - Before you start installation..... 27
 - Requirements for installation next to an inspection pit 28
 - Preparations for electrical connections 400 V 29
 - Preparations for hydraulic connections..... 29
 - Installation 29
 - Installing the floor units..... 30
 - Install hydraulics..... 31
 - Electrical connections control box 35
 - Connections overview PD5710/PD5720 36
 - Connections overview PD5715/PD5730 37

- Electrical connections control lamp38
- Mains switch and emergency stop.....38
- De-aerate the system39
- System checks39
- Chapter 7 Preventive maintenance41**
- Safety for maintenance41
- Maintenance schedule41
- Check the hydraulic system42
- Chapter 8 Adjustments43**
- DIP-switch settings43
- Adjust power supply44
- Adjust oil pressure45
- Chapter 9 Troubleshooting.....47**
- Troubleshooting table47
- Chapter 10 Corrective maintenance.....49**
- Install a new application program.....49
- Chapter 11 Disposal.....51**
- Chapter 12 Parts lists.....53**
- Overview drawing hydraulic control unit54
- Parts list.....55
- Overview drawing wireless control lamp56
- Parts list wireless control lamp.....57
- Overview drawing floor module58
- Parts list.....59
- Index.....61**

About this manual

In This Chapter

Audience	5
Scope	5
Organization	6
Lay-out conventions	6
Related documents	7

Audience

This service manual is intended for persons who maintain the play detector.

Altus-Escon-Company B.V. requires that these persons:

- ▶ Have sufficient technical knowledge and experience to do the assigned tasks
- ▶ Can recognize and prevent hazards
- ▶ Have read and understand this manual
- ▶ Have been correctly trained
- ▶ Follow the procedures in this manual

Scope

The purpose of this manual is to:

- ▶ Describe the system's operating principles and general construction
- ▶ Explain safety features and safety precautions
- ▶ Highlight possible hazards
- ▶ Describe the installation and calibration of the system
- ▶ Describe procedures to maintain the system
- ▶ Describe solutions to system problems

Organization

This service manual is organized into:

- ▶ Safety (on page 11): describes safety features on the play detector and safety precautions to obey when you operate or do work on the system. Read this section before installation, operation and maintenance.
- ▶ Functional description (on page 17): contains a functional description of the play detector.
- ▶ Transport and Installation (on page 27): contains information on installation of the play detector and transport.
- ▶ Preventive maintenance (on page 41): contains maintenance procedures that can be done by the engineer.
- ▶ Adjustments (on page 43): contains the calibration procedures.
- ▶ Troubleshooting (on page 47): contains procedures to solve problems encountered during operation or maintenance and lists error messages.
- ▶ Corrective maintenance (on page 49): contains procedures to replace parts of the play detector.
- ▶ Parts lists (on page 53): contains parts lists and drawings.

Lay-out conventions

In this manual, we use a number of typographical conventions to highlight particularly important information, and to guide you through the manual. This section lists these conventions.

Three types of list are used:

- 1) Lists that are numbered (like this sentence), contain actions you must carry out in sequence.
 - ▶ In lists that use bullets (like this sentence), the sequence is not critical.
- ❶. Legend numbers in figures

Note

Text with additional information, such as expanded explanations, hints or reminders.

Caution

Indicates situations that can damage the system.

Warning

Indicates the presence of a hazard that can cause death or severe personal injury, if the hazard is not avoided.

Commands (like menu items and buttons) are **bold**. Menu names are also **bold**.

Example: On the remote control press **4**.

Information that needs special attention, is *italic*.

Example: Use the **Emergency Stop** button *only* in emergencies.

In online documents, cross-references are underlined and blue. You can click on the link to view this topic. When you are reading this document on paper, the cross-reference will tell you the topic title and the page number.

Example: see Organization (on page 6).

Related documents

- ▶ User Manual
- ▶ Quick Reference Guide

Introduction

In This Chapter

The play detector 9

The play detector

The hydraulic play detector is designed for statutory testing of Heavy Goods Vehicles (HGV) and Public Service Vehicles (PSV). The play detector checks for play and wear in the suspension and steering parts.

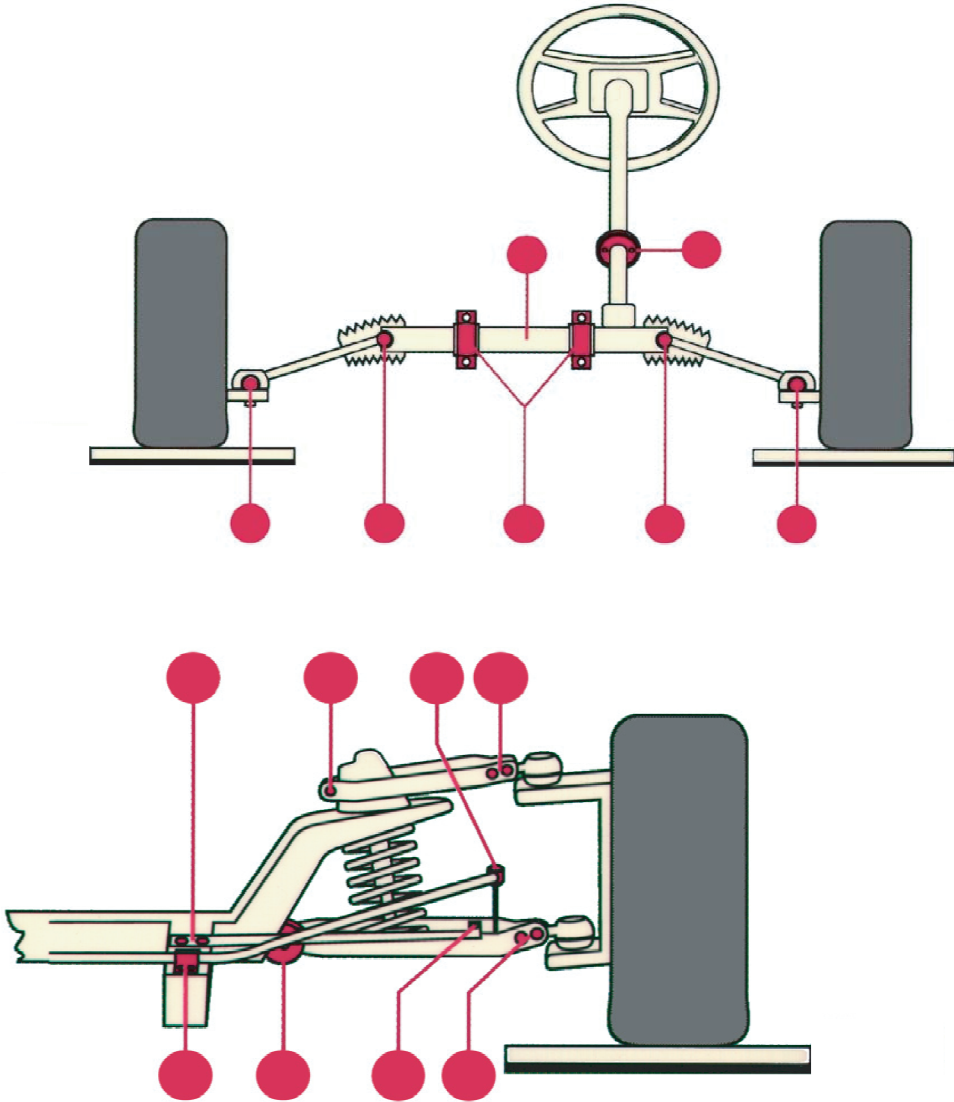

The system consists of two platforms and a control unit with a control lamp. The vehicle is placed with one axle on the platforms. The platforms will pull the wheels along, so the wheel will move relative to the vehicle body. This reveals play and wear in the suspension and steering components.

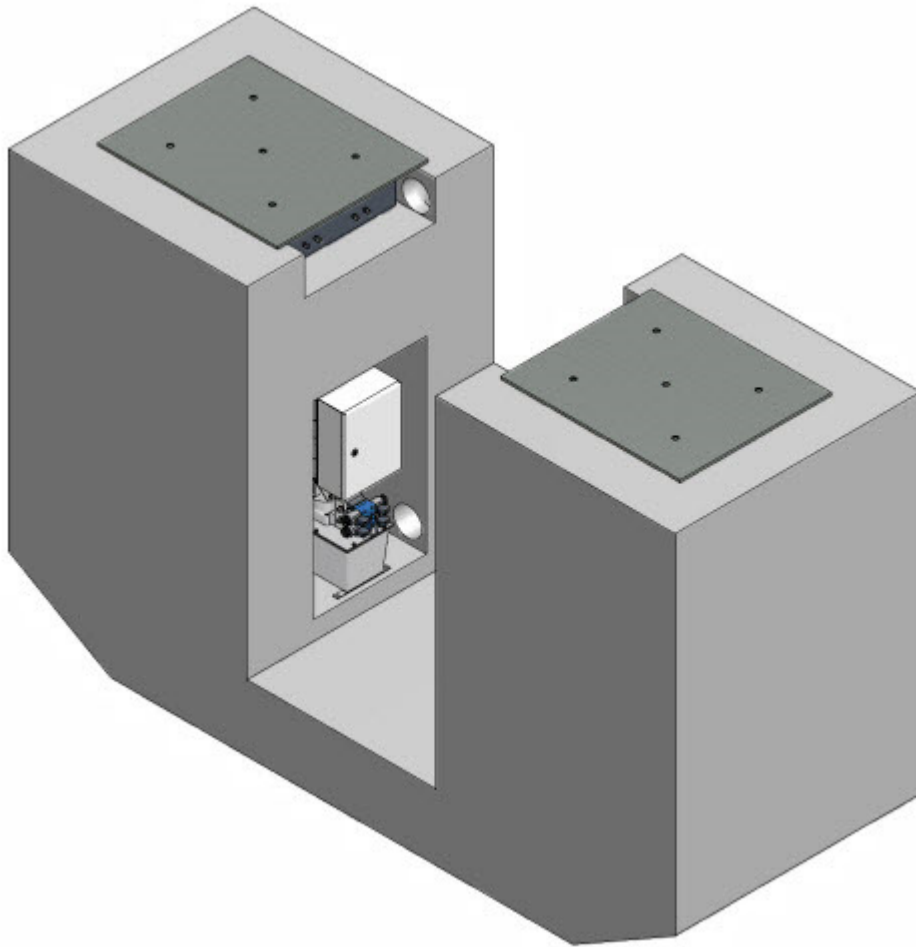

You control the platforms using a handheld control lamp: this means that you can move the platforms while you are underneath the vehicle to inspect it. A bracket is supplied for safe storage of the control lamp.

Safety

In This Chapter

General safety instructions	11
Safety around hydraulic systems	12
Safety for maintenance	12
System safety features	12
Lockout procedure: maintenance safety	13

General safety instructions

Warning

In case of te PD 5715 and 5730, keep the wireless control lamp at a save place. If you accidentally touch the the control lamp, the plates move immediately.

- ▶ Always follow the instructions in this manual to prevent damage to the play detector and vehicle, and injuries to personnel.
- ▶ Only properly trained and authorized personnel are allowed to operate and service the play detector.
- ▶ Lock the mains switch when the play detector is not in use.
- ▶ During the test, make sure nobody stands close to the mechanical unit. If necessary, block accesses or provide a color marking.
- ▶ Do not remove or short-cut the safety features.
- ▶ The operator is only permitted to do maintenance as described in Preventive maintenance in the user manual.
- ▶ Do not park a vehicle on any part of the play detector.
- ▶ The play detector must only be operated within its rated capacity. The play detector is designed for large vehicle testing: Heavy Goods Vehicles (HGV) and Public Service Vehicles (PSV).
- ▶ Read the user manual before you install the batteries on the wireless control lamp.
- ▶ Read the user manual before you connect the adapter to the wireless control lamp.
- ▶ Do not install non-rechargeable batteries in the wireless control lamp. Non-rechargeable batteries explode when charged.
- ▶ Always install the battery charger near the play detector. When you push a button accidentally, the plates of the play detector move immediately.

Safety around hydraulic systems

The hydraulic system in the play detector uses a high pressure. Always be careful when working in the vicinity of a hydraulic system.

Warning

Pinhole leaks can cause serious injuries: liquid under pressure can be injected into the skin as if from a hypodermic syringe.

You will feel only a slight stinging sensation at the time of injection. Several hours later, the wound will begin to throb and severe pain begins. If not treated, you may lose the infected area.

Consult a doctor immediately if you suspect injection.

- ▶ Wear oil-proof gloves.
- ▶ Never use your hand or any other part of your body to try and locate a leak: use a piece of wood or cardboard instead.

Safety for maintenance

In addition to the general instructions (see "General safety instructions" on page 11), the following instructions apply when you maintain the unit:

- ▶ Before connecting the equipment, make sure all units are set to the local voltage and frequency. Make sure the 3-phase motors are connected in Y or Delta configuration, whichever is appropriate for your local voltage.
- ▶ Switch off the electrical supply and lock the mains switch before opening any unit of the play detector.
- ▶ The play detector must only be operated within its rated capacity.
- ▶ Protect the electric equipment against water and humidity.
- ▶ Only a qualified technician is permitted to do work on the electrical system. He must follow procedures prescribed by national standards and the regulations of the local power company.
- ▶ Any unauthorized modification to the system voids the CE-declaration.

System safety features

The play detector has the following safety features:

- ▶ Any button on the control lamp: when you release the button, the platforms stop immediately.

If your local electrical regulations require that an emergency stop is installed, ask your installer to add the emergency stop to the power supply.

Lockout procedure: maintenance safety

Locking the play detector at the start of maintenance

To lockout the play detector:

- 1) Notify all affected employees that:
 - ▶ Servicing or maintenance is required on the play detector
 - ▶ The play detector must be shutdown and locked out
- 2) Shutdown the machine or equipment with the normal stopping procedure (see operator manual).
- 3) Apply a note to the console that the play detector is serviced.
- 4) Switch off the main switches and lock them with a padlock.

Danger
Voltage is still present inside the console.

The play detector is now locked out.

Unlocking the play detector after maintenance

To release the play detector after maintenance:

- 1) Make sure all tools and equipment have been removed from the play detector and the immediate area.
- 2) Make sure there are no employees in the work area.
- 3) Remove the padlock from the main switch.
- 4) Notify the employees that the servicing or maintenance is completed and the play detector is ready for use.

Specifications

- ▶ Maximum drive over weight: 20,000 kg per axle, 10,000 kg per wheel
- ▶ Maximum horizontal force: 30 kN per plate
- ▶ Longitudinal/transversal movement: 100 mm
- ▶ Movement speed: 40 mm/s
- ▶ Motor:
 - ▶ Power: 3.0 kW
 - ▶ Voltage: 3 phase, 400 V, 50 Hz
- ▶ Cable length PD5710/PD5720: 6.5 m
- ▶ Working pressure: 150 bar

Dimensions and weight

Play detector plate	Dimensions	950 x 800 x 217 mm (l x w x h)
	Weight	300 kg each
Hydraulic control unit	Dimensions	360 x 300 x 875 mm (d x w x h)
	Weight	36 kg

Wireless control lamp

- ▶ Working range: up to 10 m without obstacles
- ▶ Standby time: up to 3 months with fully charged batteries
- ▶ Working time with power-LED on: up to 4 hours with fully charged batteries
- ▶ Working time with power-LED off: up to 10 hours with fully charged batteries
- ▶ Charging time: up to 5 hours in case of fully discharged batteries
- ▶ Batteries: 2 x AA NiMH rechargeable, capacity 1900 – 2500 mAh (Sanyo Eneloop HR-3UTGA recommended)
- ▶ Battery charger: 5 VDC stabilized, min. 1 A

Hydraulics:

- ▶ Fluid type: H46
- ▶ Tank volume: 10 l

Functional description

This chapter describes the play detector and explains how it works.

In This Chapter

System overview	17
Floor unit	18
Control lamp PD5710	19
Control lamp PD5715	20
Control lamp PD5720	22
Control lamp PD5730	24
Hydraulic control unit	25

System overview

The main parts of the system are:

- ▶ Floor unit (on page 18)
- ▶ Hydraulic control unit (on page 25)
- ▶ Control lamp:
 - ▶ Control lamp PD5710 (on page 19)
 - ▶ Control lamp PD5715 (on page 20)
 - ▶ Control lamp PD5720 (on page 22)
 - ▶ Control lamp PD5730 (on page 24)

Floor unit

The floor unit consists of two platforms, one for the left wheel and one for the right wheel.

Each platform is moved by two hydraulic cylinders. The platforms move the wheels, revealing any play in the suspension components.

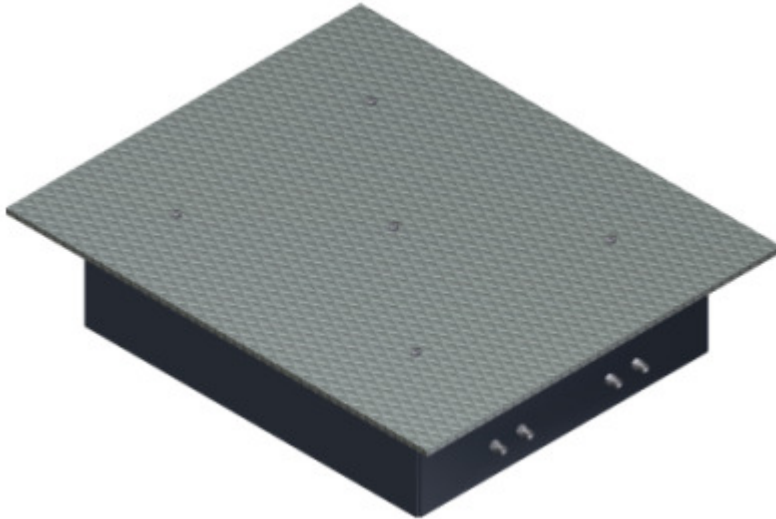

The friction between the wheel and the platform is lower than the friction of most roads. This limits the force exerted on the suspension to a safe level.

Control lamp PD5710

The play detector is provided with a wired control lamp. You use the lamp to visually check the vehicle suspension for play and wear. Buttons on the lamp allow you to control the platforms.

The figure shows an example of a control lamp.

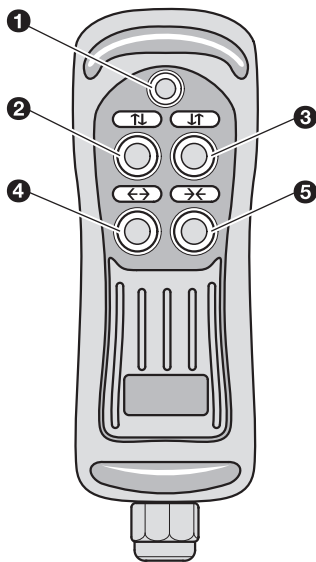

The functions of the control lamp are explained below:

BUTTON	FUNCTION
1	Switch lamp on/off
2	Move the left platform to the front, and the right platform to the rear
3	Move the left platform to the rear, and the right platform to the front
4	Move the left platform to the left, and the right platform to the right
5	Move the left platform to the right, and the right platform to the left

To move the platforms diagonally: press two buttons at the same time.

The platforms move in opposite directions. When one platform moves to the front, the other platform moves to the rear:

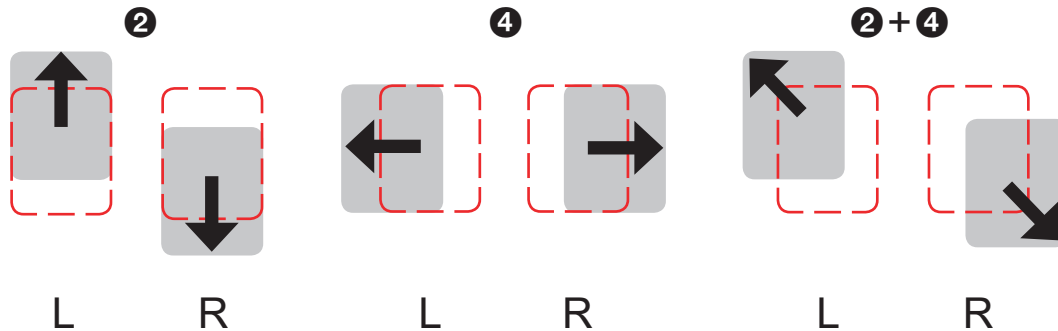

The platforms will move as long as you keep the button pressed, or until they reach the end of their stroke. Release the button to stop the platforms.

Control lamp PD5715

The play detector is provided with a wireless control lamp. You use the lamp to visually check the vehicle suspension for play and wear. The control lamp has a touch screen that allows you to control the platforms.

The wireless control lamp comes on as soon as you touch the touch screen. The control lamp shuts down if it is not used for one minute. Press the screen to activate the control lamp again.

The figure shows an example of a control lamp.

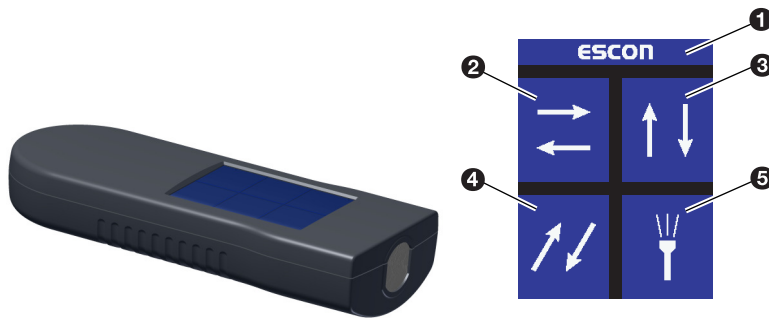

The functions of the control lamp are explained below:

BUTTON	FUNCTION
❶	Battery level. When ❶ shows a red bar, the battery level is too low.
❷	Move the platforms to the left and right.
❸	Move the platforms to the front and rear.
❹	Move each plate along the diagonal.
❺	Switch lamp on/off.

The platforms move in opposite directions. When one platform moves to the front, the other platform moves to the rear:

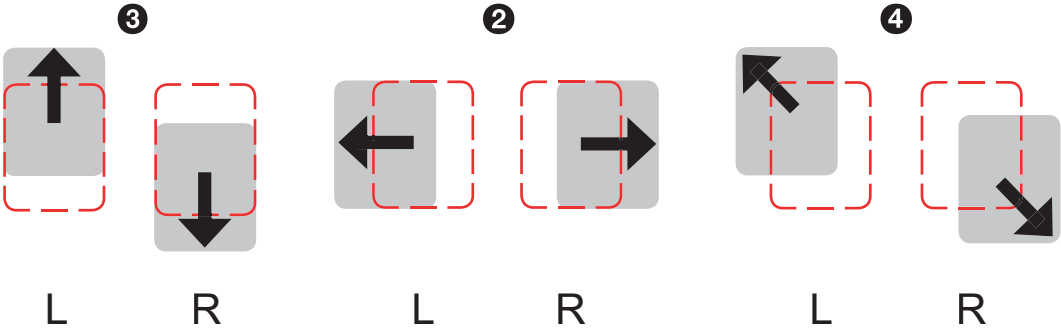

The platforms will move as long as you keep the button pressed, or until they reach the end of their stroke. Release the button to stop the platforms.

Control lamp PD5720

The play detector is provided with a wired control lamp. You use the lamp to visually check the car suspension for play and wear. Buttons on the lamp allow you to control the platforms.

The figure shows an example of a control lamp.

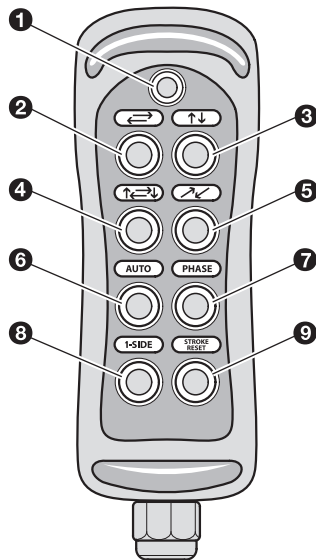

The functions of the control lamp are explained below:

BUTTON	FUNCTION
1	Switch lamp on/off.
2	Move the platforms to the left and right.
3	Move the platforms to the front and rear.
4	Move each plate in a rectangle.
5	Move each plate along the diagonal.
6	Manual/auto switch. Press the button to switch between Manual and Auto mode. <ul style="list-style-type: none"> ▶ In manual mode: when you press buttons 2-4, the plates move one stroke. ▶ In Auto mode: when you press buttons 2-4, the plates keep moving as long as you keep the button pressed.
7	Phase switch. This changes how each movement is done. <ul style="list-style-type: none"> ▶ For movement 2 and 3: move both platforms in the same direction or in opposite directions. ▶ For movement 4: reverses the direction of movement. ▶ For movement 5: switches to the other diagonal.
8	I-Side switch: <ul style="list-style-type: none"> ▶ Normally, both platforms move. ▶ Press the button to move only the left platform.

BUTTON

FUNCTION

- ▶ Press the button again to move only the right platform.
- ▶ Press the button again to move both platforms.

⑨

Stroke/Reset switch:

Move the plates to the rest position.

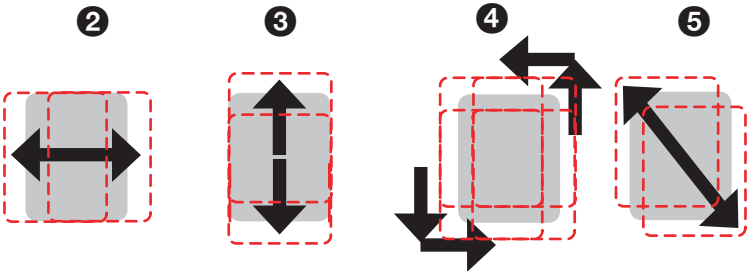

The platforms will move as long as you keep the button pressed, or until they reach the end of their stroke. Release the button to stop the platforms.

Control lamp PD5730

The play detector is provided with a wireless control lamp. You use the lamp to visually check the vehicle suspension for play and wear. The control lamp has a touch screen that allows you to control the platforms.

The wireless control lamp comes on as soon as you touch the touch screen. The control lamp shuts down if it is not used for one minute. Press the screen to activate the control lamp again.

The figure shows the buttons of the control lamp.

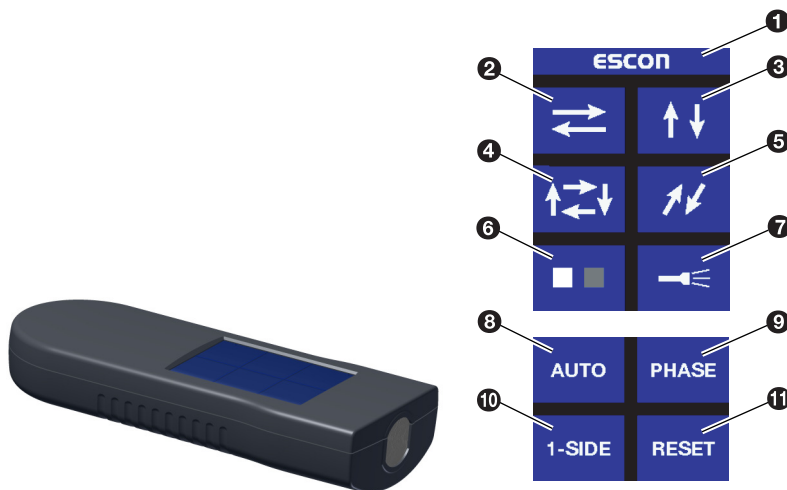

The functions of the control lamp are explained below:

BUTTON	FUNCTION
❶	Battery level. When ❶ shows a red bar, the battery level is too low.
❷	Move the platforms to the left and right.
❸	Move the platforms to the front and rear.
❹	Move each plate in a rectangle.
❺	Move each plate along the diagonal.
❻	Screen switch. Switches between the upper and lower screen.
❼	Switch lamp on/off.
❽	Manual/auto switch. Press the button to switch between Manual and Auto mode. <ul style="list-style-type: none"> ▶ In manual mode: when you press buttons 2-4, the plates move one stroke. ▶ In Auto mode: when you press buttons 2-4, the plates keep moving as long as you keep the button pressed.
❾	Phase switch. This changes how each movement is done. <ul style="list-style-type: none"> ▶ For movement ❷ and ❸: move both platforms in the same direction or in opposite directions. ▶ For movement ❹: reverses the direction of movement. ▶ For movement ❺: switches to the other diagonal.

BUTTON	FUNCTION
10	<p>I-Side switch:</p> <ul style="list-style-type: none"> ▶ Normally, both platforms move. ▶ Press the button to move only the left platform. ▶ Press the button again to move only the right platform. ▶ Press the button again to move both platforms.
11	<p>Stroke/Reset switch:</p> <p>Move the plates to the rest position.</p>

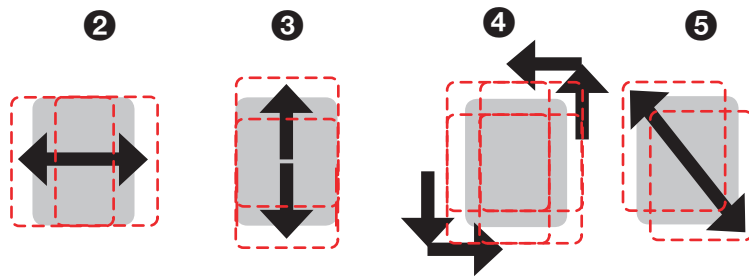

The platforms will move as long as you keep the button pressed, or until they reach the end of their stroke. Release the button to stop the platforms.

Hydraulic control unit

The hydraulic control unit contains the following items:

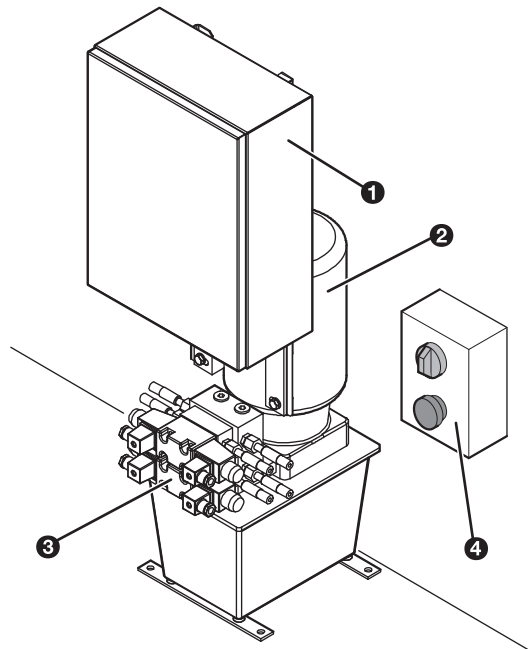

- 1) Control box
This contains the electrical components.
- 2) Hydraulic motor and pump
This provides power to the platforms.
- 3) Valve block
This contains the hydraulic valves.
- 4) Main switch and emergency stop button (not supplied)

Note

If your local electrical regulations require that an emergency stop and/or mains switch is installed, ask your installer to add these to the power supply.

Transport and Installation

In This Chapter

Transport and hoisting	27
Storage	27
Before you start installation	27
Installation	29

Transport and hoisting

All components are delivered packed and tied on pallets. You can move them with a pallet jack or a fork-lift truck.

Storage

The original packing is designed to protect the equipment during shipment and storage. The storage area must be clean, dry and temperature controlled between +5 and +40 °C (+41 °F and 104 °F).

Before you start installation

Danger
Remove or switch off the fuses from the main electrical supply before you start the installation.

Requirements for installation next to an inspection pit

Install the floor units on either side of an inspection pit.

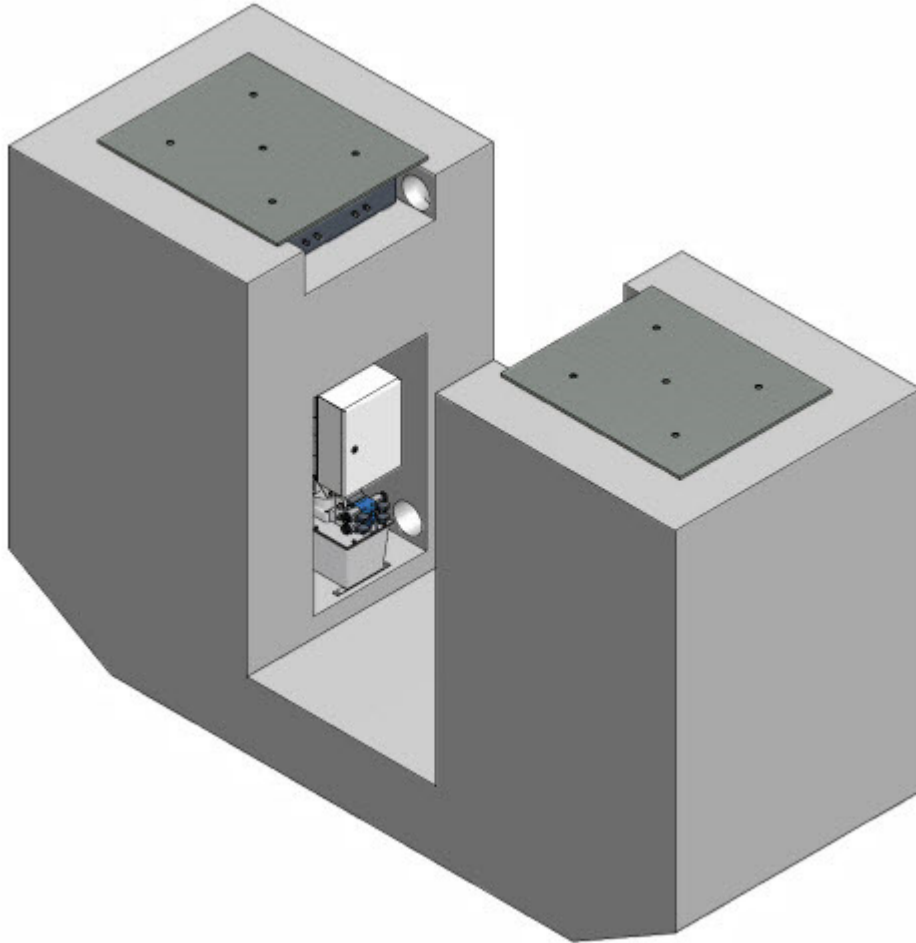

Take the following points into account when designing the pit and installing the play detector:

- ▶ The pit must be deep enough to perform the testing/inspection operations safely.
- ▶ The pit must be provided with guards and ways to escape in compliance with the regulations.
- ▶ Provide a pit for the floor unit. For the pit dimensions, contact the factory.
- ▶ Provide a location for the hydraulic control unit in or near the pit. The cable on the control lamp is 6.5 m long. Place the hydraulic control unit so that you can easily use the control lamp inside the pit underneath a vehicle.
- ▶ The hydraulic hoses enter the floor unit from one side. Provide ducting for the hydraulic hoses. Make sure any bends in the ducting are wider than the minimum bend radius for the hoses.
- ▶ Install the system in a dry area. Rain water dripping off a vehicle will not harm the units, but make sure the units are never flooded. Install a water drain at the lowest point in the pit.
- ▶ Permitted floor load must be at least 100 kN/m².
- ▶ The surface must be flat: parallel within 0.2 cm.

Preparations for electrical connections 400 V

Information on other voltages is available on request.

Cable requirements 380-400 V

- ▶ The mains power cable to the control unit must be a 5-wire cable (3 phases plus neutral and ground).
- ▶ The neutral wire is mandatory.
- ▶ For a cable length of up to 15 m, the cable diameter must be $5 \times 1.5 \text{ mm}^2$. For longer cables, use a thicker gauge cable.
- ▶ The control unit does not include a mains switch or emergency stop button. Have your installer add a separate mains switch into the mains wiring to the control unit.
- ▶ We recommend you add an emergency stop button.

Power requirements

- ▶ Use coupled fuses for the separate group. If one phase blows a fuse, then all phases must automatically be disconnected. Not complying with this condition voids the warranty.
- ▶ Use a separate 3-phase group to feed the play detector. The group must be fused at 16 A.

Note

If problems occur due to the high starting current, apply a type C circuit breaker.

Preparations for hydraulic connections

Note

The hydraulic hoses and oil are not part of the delivery.

Use hydraulic hoses to this specification:

- ▶ SAE100 RIT 3/8

Take the minimum bend radius of the hoses into account when installing the hoses.

Installation

Install the play detector in the following sequence:

- 1) Install the floor units.
- 2) Install the hydraulic control unit.
- 3) Connect the floor units to the control unit.
- 4) Connect the control unit to the mains.
- 5) Make sure the system functions correctly.

Installing the floor units

- 1) Remove the top plate.

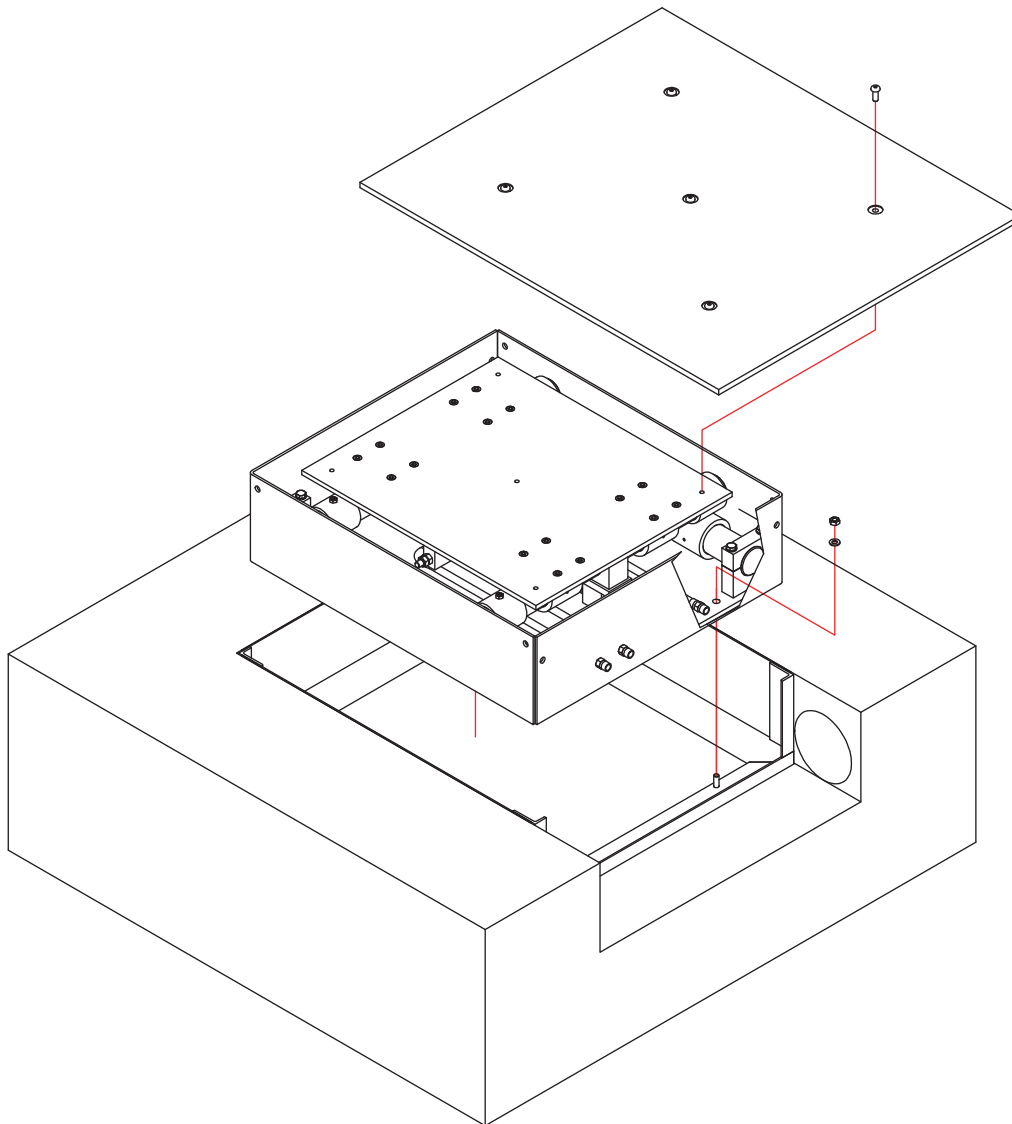

- 2) Install the floor unit on the casing.
- 3) Secure the floor unit with washers and nuts.
- 4) Install the hydraulic control unit.

Install hydraulics

Note

The hydraulic hoses and oil are not part of the delivery.

- 1) Install the hydraulic control unit, for example, next to the lift.
- 2) Connect the hydraulic hoses to the cylinders according to the figure below.

Note

Or prepare the hoses with a hydraulic coupling for filling with oil (see "De-aerate the system" on page 39).

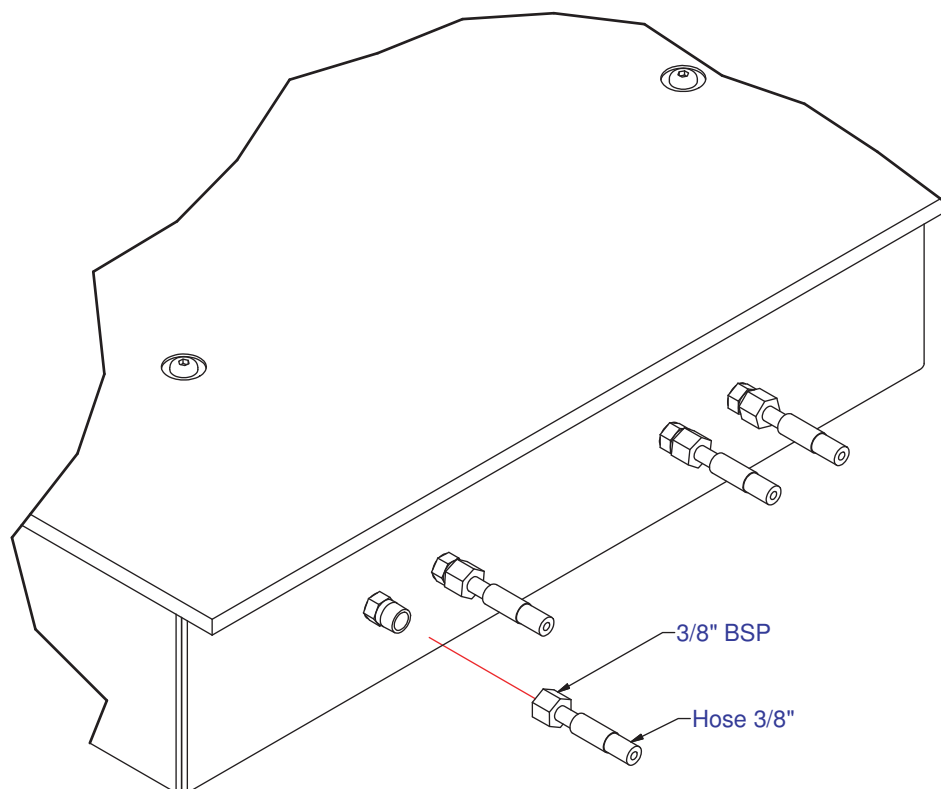

Take the minimum bend radius of the hoses into account when installing the hoses.

- 3) Connect the hydraulic hoses to the hydraulic control unit. The connection points are marked with connection numbers, make sure you make the correct connections: A1 to A1, B1 to B1 etc.

See the hydraulic scheme and the figure that shows the hose connection.

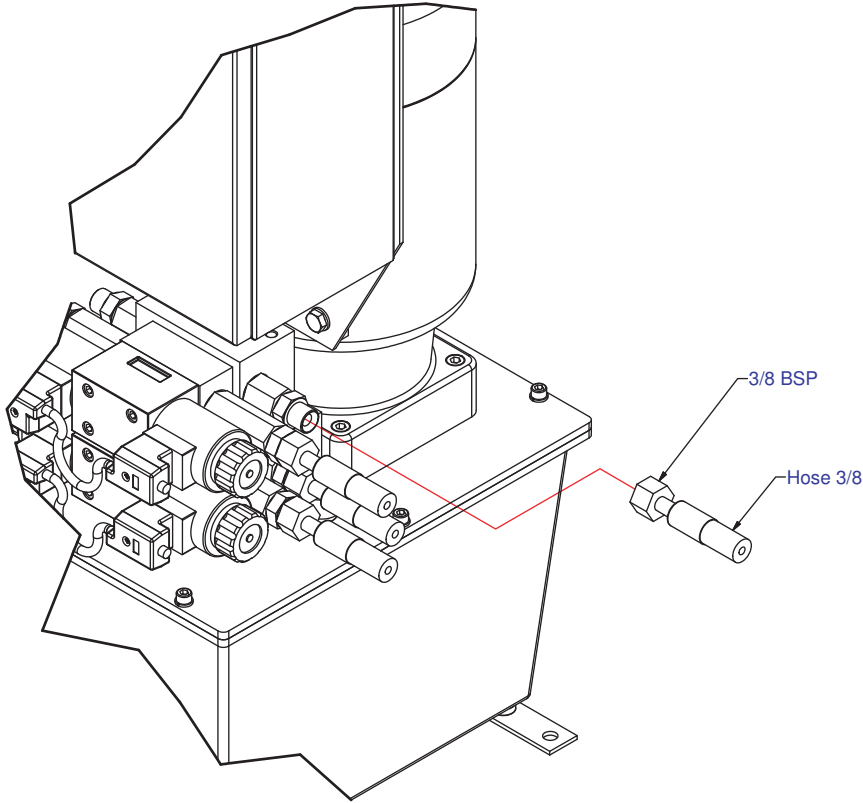

Hydraulic connections PD5710/PD5715:

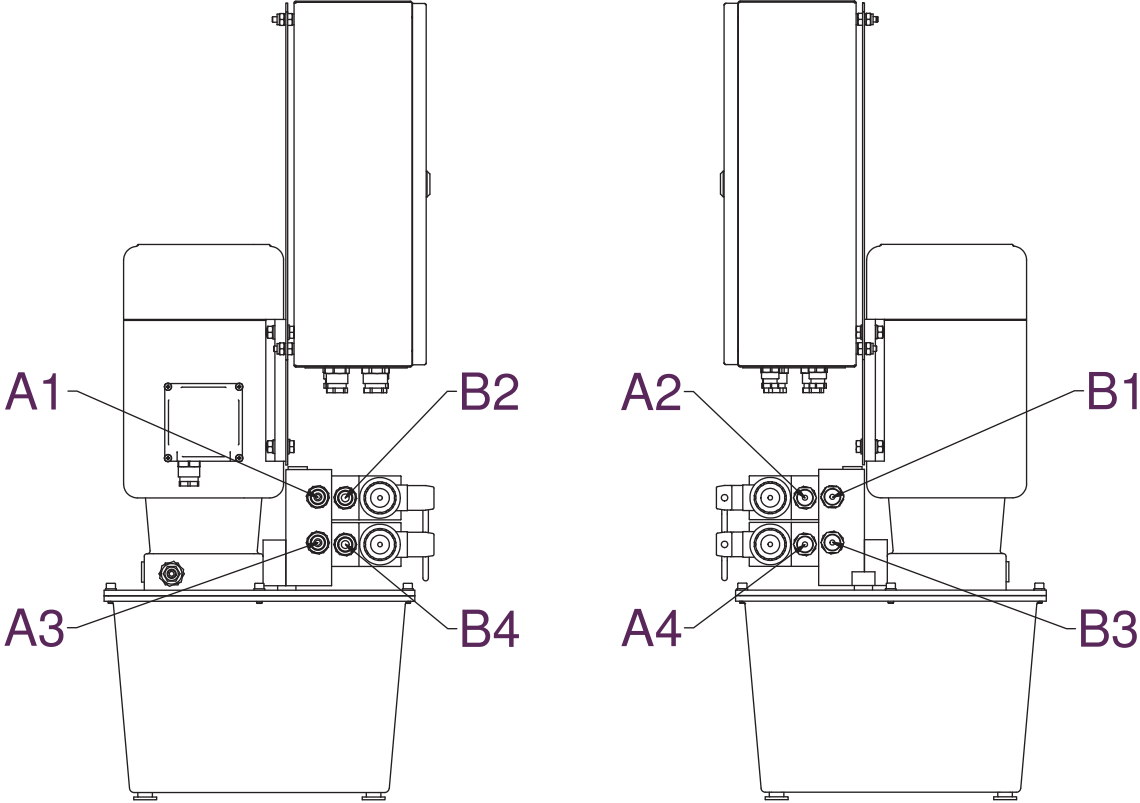

Hydraulic connections PD5720/PD5730:

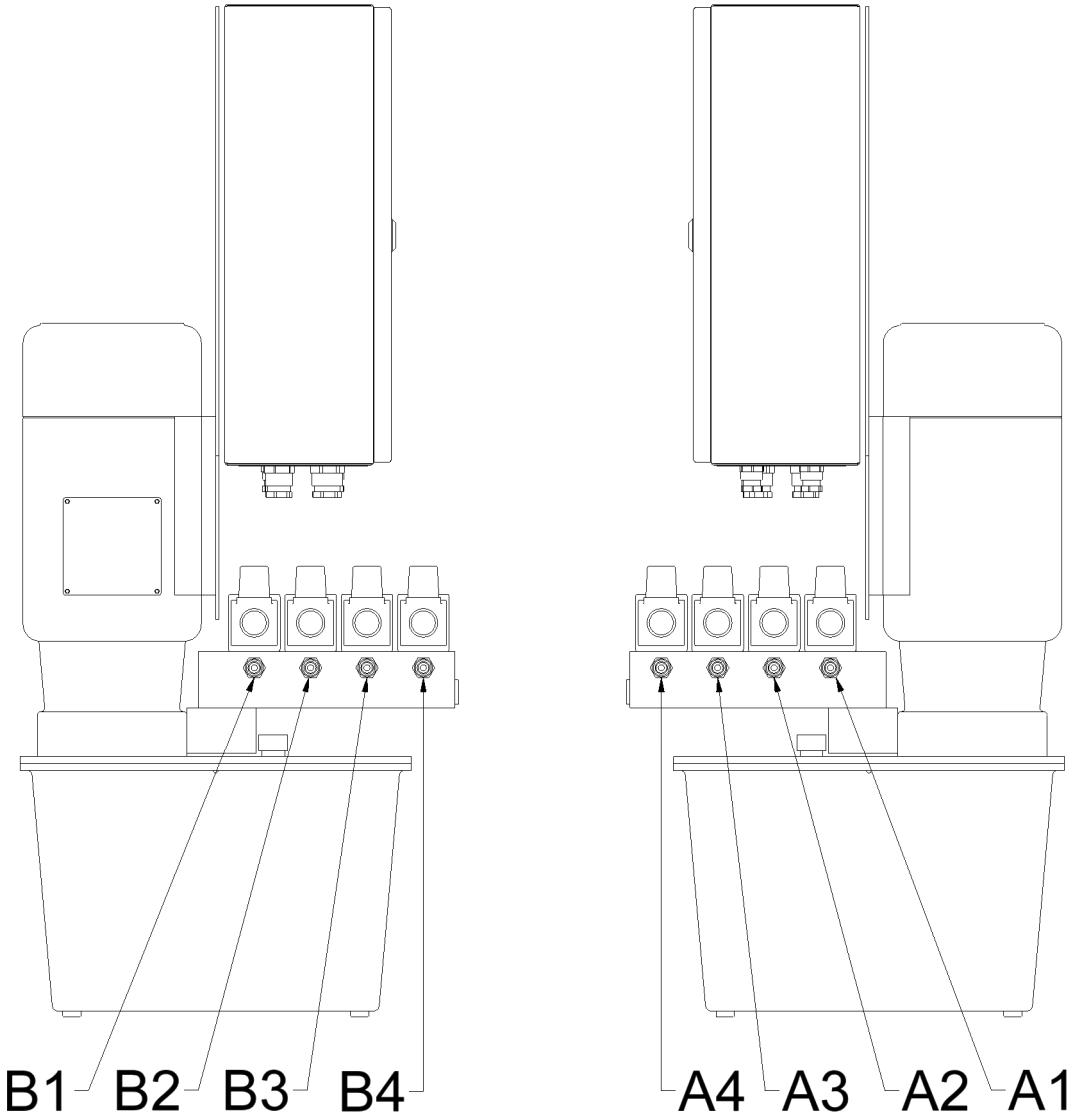

The hydraulic scheme is also available inside the control box.

Electrical connections control box

Danger
 Remove or switch off the fuses from the main electrical supply before you start the installation.

Connect the control box as follows:

- 1) Guide the mains input cable through the cable gland into the control box.

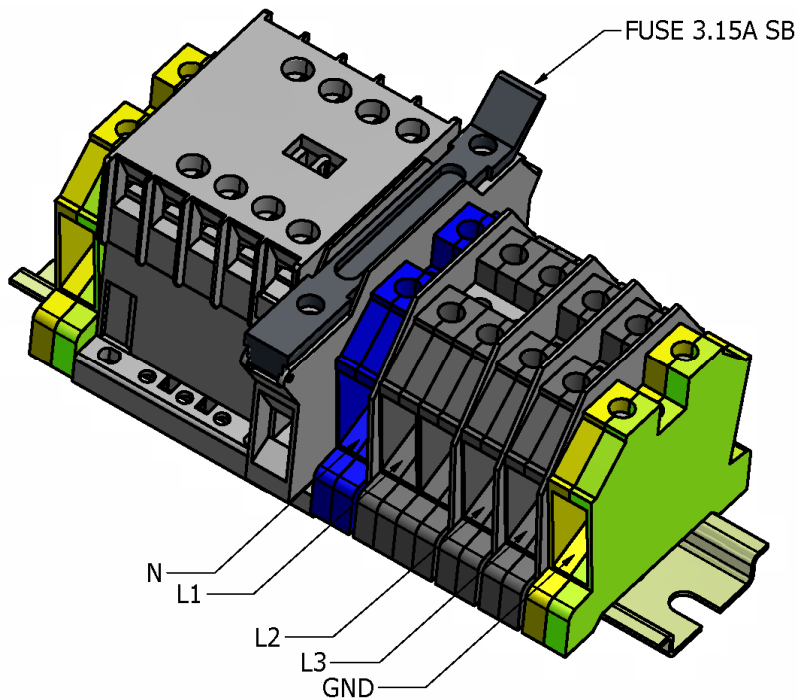

- 2) Connect the mains input cable to the terminals in the control box. Make sure you connect the three phases in the correct order (N, L1, L2, L3, ground).
- 3) Make sure the two screws of all terminals on both sides of the power rail are tensioned correctly. It is possible that some screws have come loose during transportation.
- 4) Make sure all connections are correct.
- 5) Check the direction of rotation of the pump motor, the correct turning direction is shown by an arrow on the side of the motor. If the motor turns in the wrong direction, change the wiring sequence to N, L2, L1, L3, ground.

Connections overview PD5710/PD5720

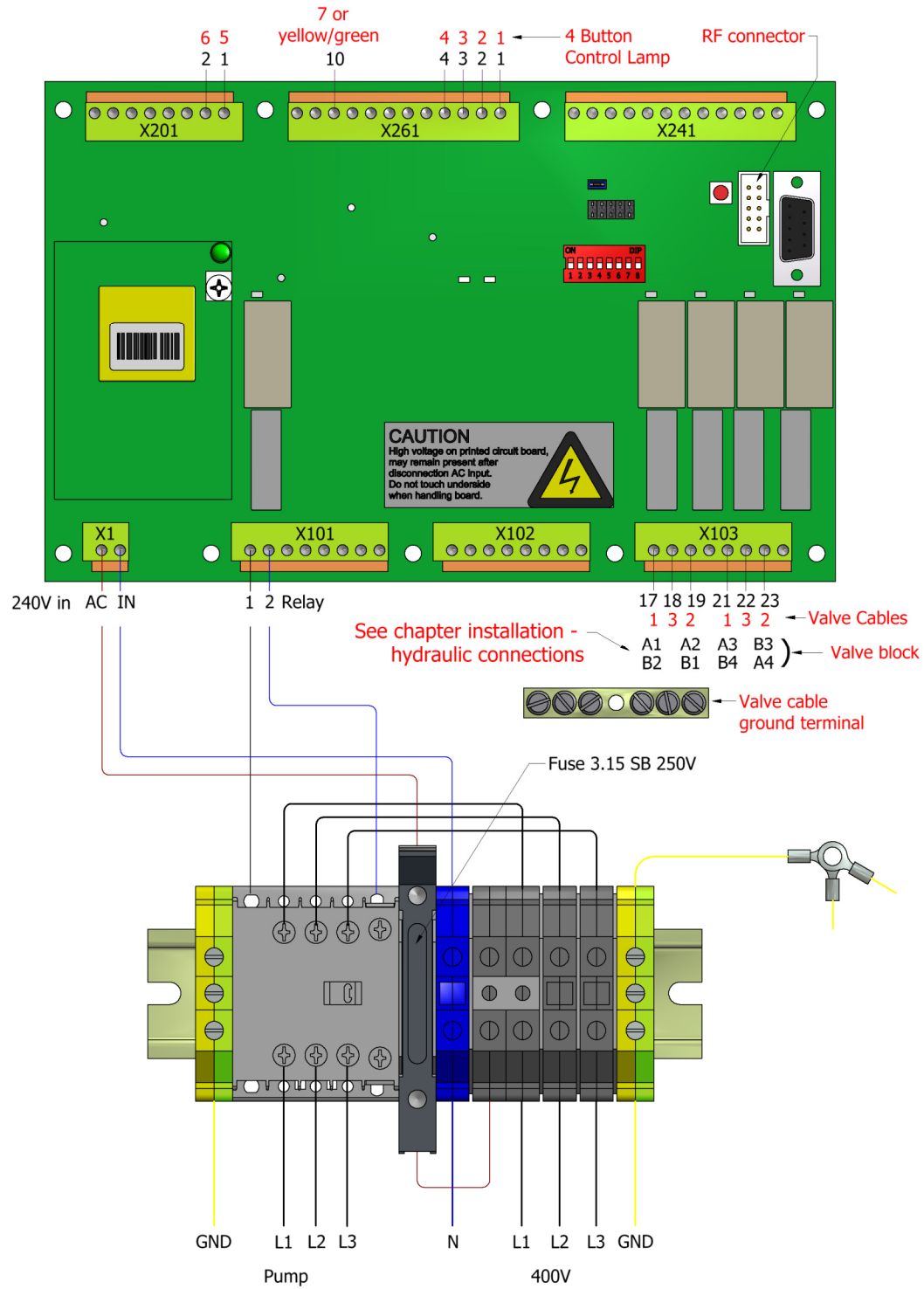

Connections overview PD5715/PD5730

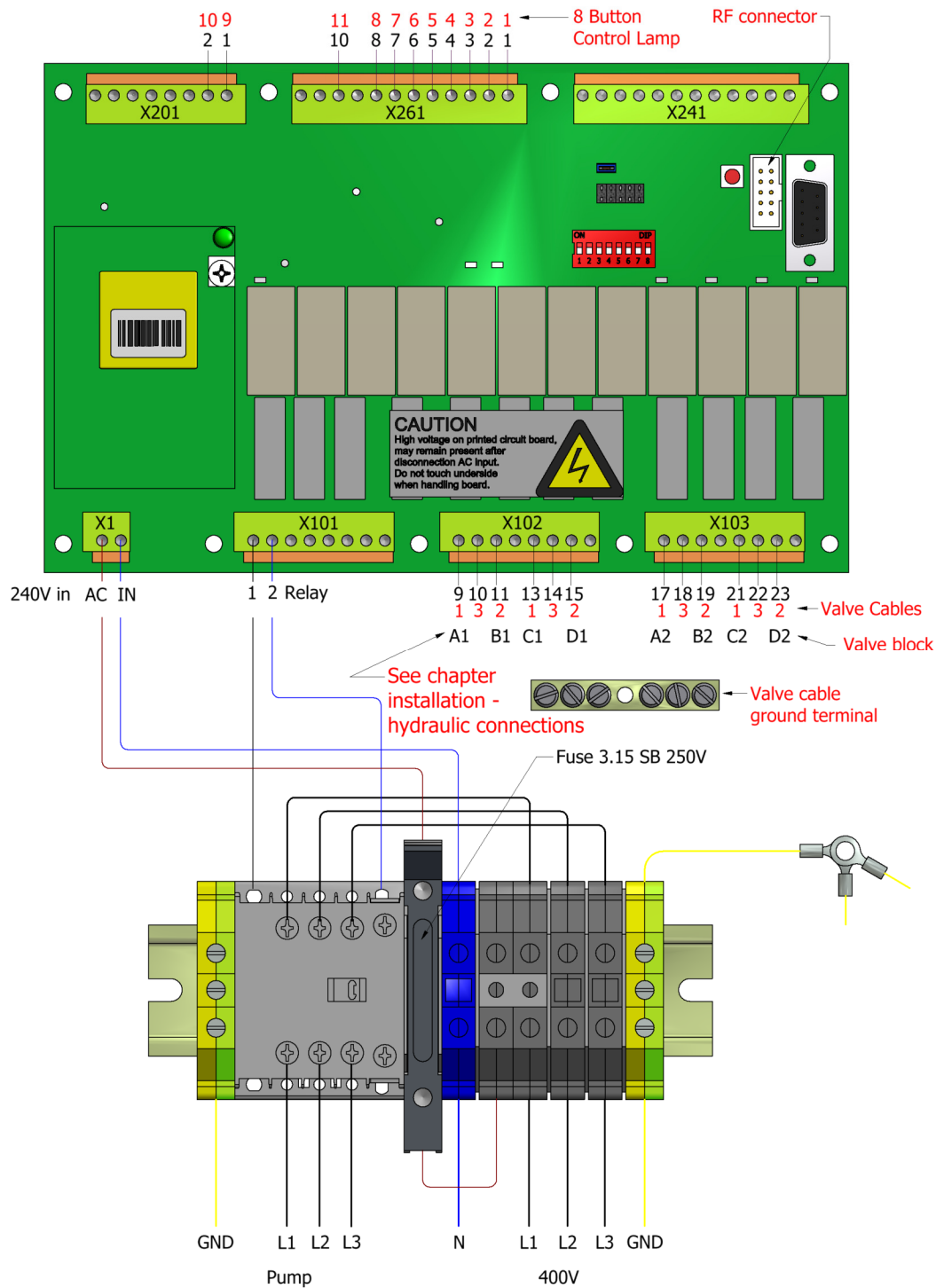

Electrical connections control lamp

CPU – PD6/12	FUNCTIONS	BUTTON NUMBER	5 BUTTON CONTROL LAMP PDXX10/15 WIRE NUMBER	9 BUTTON CONTROL LAMP PDXX20/30 WIRE NUMBER
X201 – 1	lamp +12V	1	5	9
X201 – 2	lamp gnd	1	6	10
X261 – 1	switch 1	2	1	1
X261 – 2	switch 2	3	2	2
X261 – 3	switch 3	4	3	3
X261 – 4	switch 4	5	4	4
X261 – 5	switch 5	6		5
X261 – 6	switch 6	7		6
X261 – 7	switch 7	8		7
X261 – 8	switch 8	9		8
X261 – 10	switch common		7	11
				12 not connected

Connector voltage

X201 (1-2)	12V
X261	0 – 5V
X101	0 – 230V
X102	0 – 230V
X103	0 – 230V

Mains switch and emergency stop

Place the mains switch and emergency stop near the area where you will be working when you use the play detector, for example in the pit.

Wire the emergency stop so that it interrupts the neutral wire. This interrupts the supply to the control unit and will stop the system.

Caution

When wired like this, the system still contains high voltage after an emergency stop.

De-aerate the system

De-aerate the system as follows:

- 1) At each cylinder connect both hoses as a loop with a hydraulic coupling:
 - ▶ A1 - B1
 - ▶ A2 - B2
 - ▶ A3 - B3
 - ▶ A4 - B4

2) Set DIP-switch 6 to on.

3) Switch the system on.

4) Press the buttons on the control lamp to simulate the movements.

After you pressed the buttons a few times, the hoses should be filled with oil and the air is removed.

5) Fill the cylinders with oil.

6) Connect the hoses to the cylinders (see "Install hydraulics" on page 31).

7) Shut down the play detector.

8) Set DIP-switch 6 to off.

System checks

Use the following checks at the end of installation and during maintenance. These checks indicate whether the system is functioning correctly.

System check

The hydraulic system in the play detector uses a high pressure. Always be careful when working in the vicinity of a hydraulic system.

Warning

Pinhole leaks can cause serious injuries: liquid under pressure can be injected into the skin as if from a hypodermic syringe.

You will feel only a slight stinging sensation at the time of injection. Several hours later, the wound will begin to throb and severe pain begins. If not treated, you may lose the infected area.

Consult a doctor immediately if you suspect injection.

- ▶ Wear oil-proof gloves.
- ▶ Never use your hand or any other part of your body to try and locate a leak: use a piece of wood or cardboard instead.

To make sure the play detector functions correctly:

- 1) Switch the system on.
- 2) Move the platforms to their end stops (left and right, front and rear): the platforms must move smoothly.
- 3) Check for hydraulic leaks.

Preventive maintenance

This chapter describes the preventive maintenance the service engineer is responsible for.

In This Chapter

Safety for maintenance	41
Maintenance schedule	41
Check the hydraulic system	42

Safety for maintenance

In addition to the general instructions (see "General safety instructions" on page 11), the following instructions apply when you maintain the unit:

- ▶ Before connecting the equipment, make sure all units are set to the local voltage and frequency. Make sure the 3-phase motors are connected in Y or Delta configuration, whichever is appropriate for your local voltage.
- ▶ Switch off the electrical supply and lock the mains switch before opening any unit of the play detector.
- ▶ The play detector must only be operated within its rated capacity.
- ▶ Protect the electric equipment against water and humidity.
- ▶ Only a qualified technician is permitted to do work on the electrical system. He must follow procedures prescribed by national standards and the regulations of the local power company.
- ▶ Any unauthorized modification to the system voids the CE-declaration.

Maintenance schedule

Note

Most of the parts of the test lane are free of any maintenance. The bearings are greased for life.

FREQUENCY	ACTION	REFERENCE
Every 6 months	Check the hydraulic hoses for leaks	Check the hydraulic system (on page 42)
	Check the oil level in the hydraulic control unit.	
Every 12 months	Check the bearings of the floor units.	
Every 2 years	Replace oil.	

Check the hydraulic system

Work safely when checking the hydraulic system (see "Safety around hydraulic systems" on page 12).

To check the hydraulic system for leaks:

- ▶ Wear oil-proof gloves.
- ▶ Never use your hand or any other part of your body to try and locate a leak: use a piece of wood or cardboard instead.
- ▶ Small (pinhole) leaks may be difficult to detect. Sometimes the only evidence is a small puddle of oil.

Adjustments

In This Chapter

DIP-switch settings	43
Adjust power supply	44
Adjust oil pressure	45

DIP-switch settings

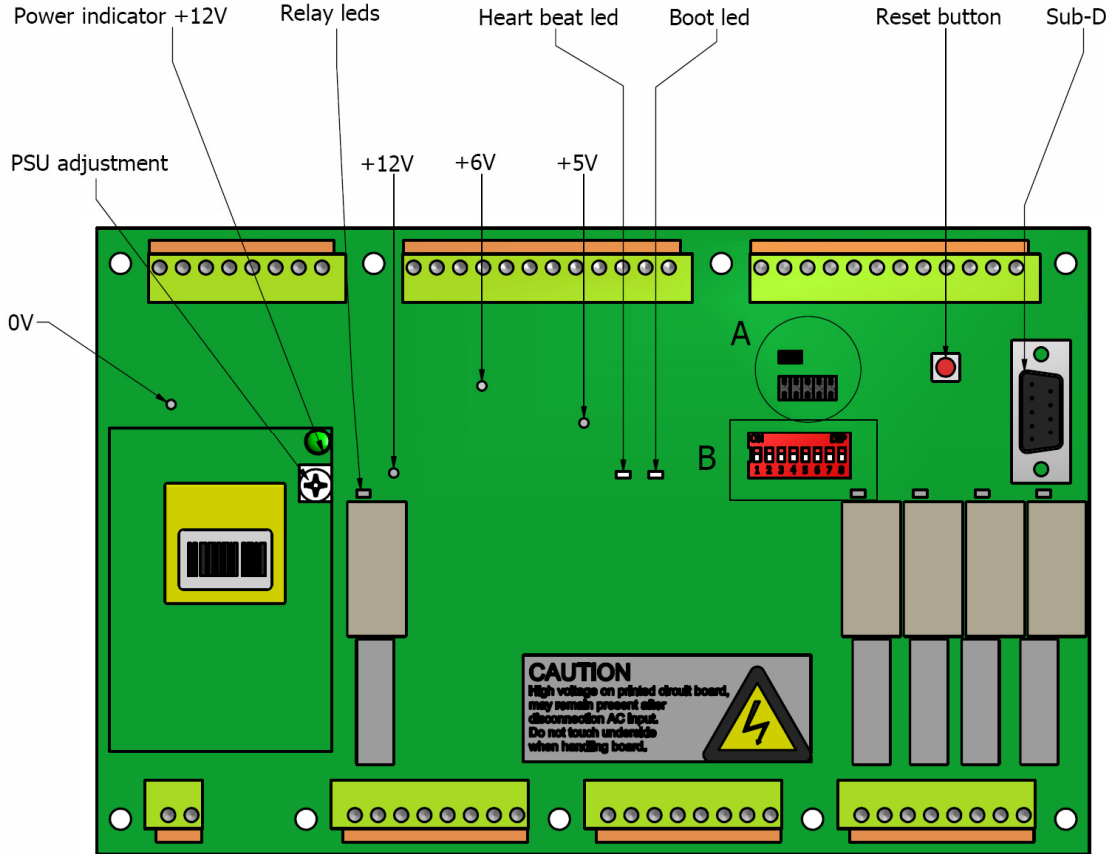

The table shows the available DIP-switches and their function.

DIP-SWITCH NUMBER	FUNCTION
4	Pressure check: set DIP-switch 4 to on. After reset the motor runs for 10 s.
5	Center the plate of the floor unit on startup: set DIP-switch 5 to on.
6	De-aerate system (see "De-aerate the system" on page 39).
7	Self-running demo mode: set DIP-switch 7 to on.

Warning
Never enable the self-running demo mode during normal use.

8 Software update (see "Install a new application program" on page 49)

The new DIP-switch settings become active if you restart the play detector or press the reset button on the CPU board.

Adjust power supply

Make sure that the following voltages are within the indicated range (see "DIP-switch settings" on page 43):

MEASURING POINTS		ALLOWED RANGE
0V	+12V	11.50 - 12.50V
0V	+6V	5.7 - 6.3V
0V	+5V	4.8V - 5.2V

If the voltages are out of the allowed range, adjust as follows:

- 1) Measure the voltage between the 0V and +12V measuring points.
- 2) Adjust the voltage to 12.0 V with the PSU adjustment screw.
- 3) Make sure that the other voltages (5 and 6V) are still within range.

Adjust oil pressure

To adjust the oil pressure, turn the pressure adjustment screw.

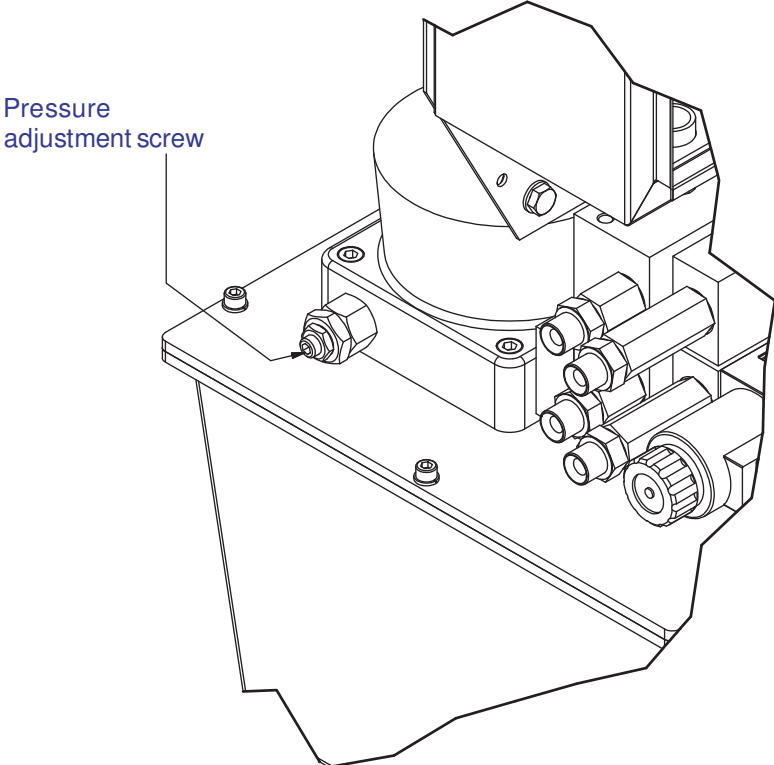

Troubleshooting

This chapter helps to find solutions for problems that can occur when you use the play detector.

In This Chapter

Troubleshooting table

47

Troubleshooting table

SYMPTOM	POSSIBLE CAUSE	ACTION
Platform does not move	<ul style="list-style-type: none"> ▶ No mains supply ▶ Wrong rotation direction of motor ▶ Insufficient oil pressure ▶ Air in hydraulic system ▶ Fuse has blown 	<p>Check the mains supply.</p> <p>Make sure the motor rotates in the direction of the arrow. If not, swap the phases of the motor cable.</p> <p>Check the oil supply.</p> <p>Check the hydraulic system (on page 42).</p> <p>De-aerate the system (on page 39).</p> <p>Replace the fuse.</p>
Platform moves erratically.	<ul style="list-style-type: none"> ▶ Air in hydraulic system 	De-aerate the system (on page 39).
Control lamp does not come on	<ul style="list-style-type: none"> ▶ No mains supply ▶ Fuse has blown ▶ Lamp is defective 	<p>Check the mains supply.</p> <p>Replace the fuse.</p> <p>Replace the lamp.</p>
	<p>In case of the wireless control lamp:</p> <ul style="list-style-type: none"> ▶ The wireless control is charging ▶ Battery charge is low 	Charge the wireless control lamp and wait until the batteries are fully charged.

Corrective maintenance

If parts of the system must be replaced, contact your local sales support.

In This Chapter

Install a new application program 49

Install a new application program

If the factory contacts you and wants you to install a new application program onto the CPU board of the play detector, follow the steps below.

The following is required for a successful installation:

- ▶ A PC or laptop running Windows 2000 or higher with AVRprog installed. Contact the factory if this program is not available.
- ▶ Serial port or USB port with RS232 adapter.
- ▶ NULL-modem cable 9p female <> 9p female, pin connections: 2<>3, 3<>2 and 5<>5.
- ▶ The new application program (.hex file) that is supplied by the factory.

Installation steps:

- 1) Make sure the system is shutdown.
- 2) Set DIP-switch 8 on the CPU board to ON.
This enables the boot loader.
- 3) Start the play detector.
- 4) Make sure LED VI 13 is on continuously.

This indicates that the boot loader is ready to receive a new application program. If not, or LED VI 14 is blinking, make sure DIP-switch 8 is correctly set and press the reset button.

If this does not help, the correct boot loader is not installed or the CPU board is not functioning. Contact the factory.

- 5) Connect the NULL-modem cable to the RS232 connector (X321) on the CPU board.
- 6) Connect the other end to the RS232 connector of the PC or laptop.

- 7) Open the PC application AVRProg.exe.

This program automatically searches all available COM ports for a CPU board.

- 8) Browse to locate the correct .hex file (for example Escon PD5710/PD5715/PD5720/PD5730-v1.0.hex).

- 9) Click the **Program** button in the Flash area to program the application on the CPU board.

Any existing application program is erased. The new application program is programmed and verified.

Warning

Make sure the CPU board and the PC or laptop stay powered on during this procedure. A power failure can severely damage the CPU board.

- 10) Make sure the AVRProg window does not show any messages.

If messages are displayed, verify the DIP-switch settings, the NULL-modem cable and repeat the procedure. Or refer to the troubleshooting section in the AVRprog user guide.

- 11) Close AVRProg.exe.

- 12) Set DIP-switch 8 on the CPU board to OFF.

This disables the boot loader.

- 13) Open a terminal program on the PC or laptop (for example TeraTerm or HyperTerminal) on the correct COM port, 19200 bps, 8 bit, 1 stop, no parity, no flow control.

- 14) Press the reset switch on the CPU board.

In the terminal program window the correct version should now be displayed (for example Escon PD5710/PD5715/PD5720/PD5730-v1.0.hex). Also during normal use of the program, various log messages are shown here.

- 15) Shut down the play detector and remove the NULL-modem cable.

- 16) Wait for 30 seconds and start the play detector. Make sure the system works as expected.

Disposal

In case of disposal separate collection of waste is mandatory in the European Community. For more information on the correct disposal of this product please contact your supplier.

Parts lists

In This Chapter

Overview drawing hydraulic control unit	54
Parts list	55
Overview drawing wireless control lamp	56
Parts list wireless control lamp	57
Overview drawing floor module	58
Parts list	59

Overview drawing hydraulic control unit

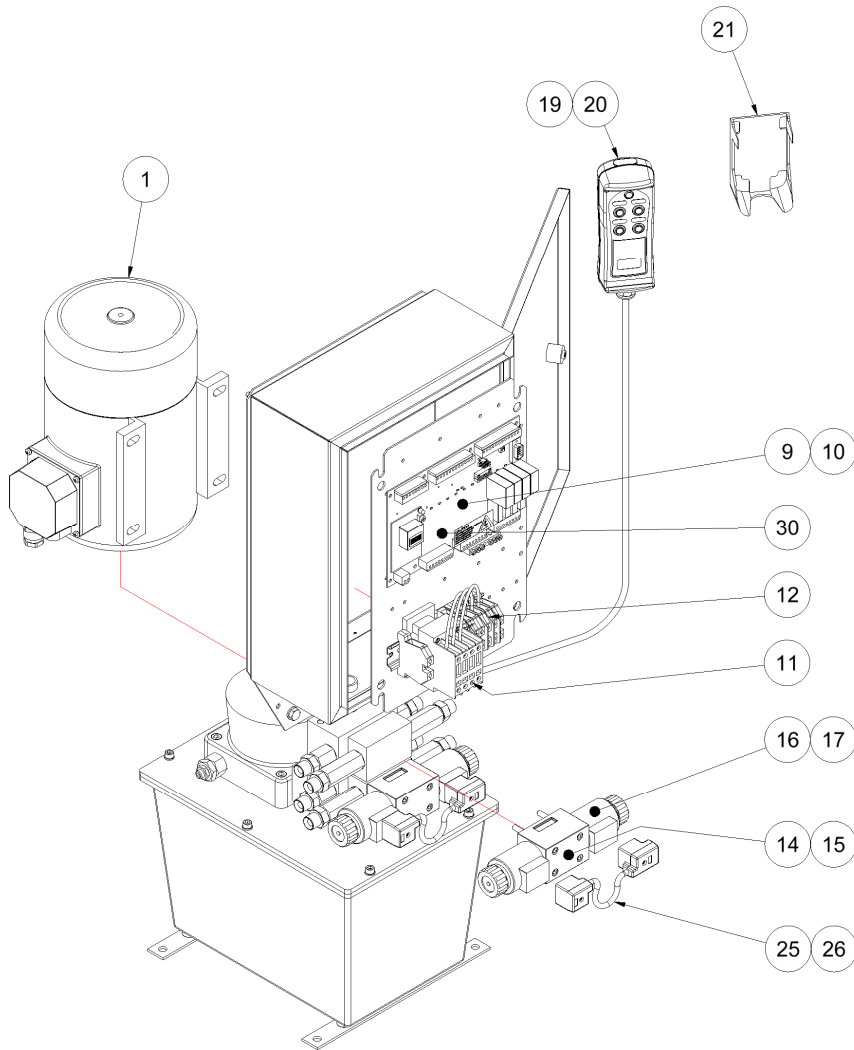

Parts list

ITEM	QTY	PART NR	DESCRIPTION
1	1	404349	Motor power pack PD57xx 230/400V 3kW
9	1	820202	CPU PD12 PDxx20-30
10	1	820210	CPU PD5 PDxx 10-15
11	1	205699	Relay 3P 4kW MC-9a LS
12	1	204218	Fuse slow 5x20 250V 3.15A
14	2	403229	Double electric 3-way valve AD3E01C (PDxx10/PDxx15)
15	4	403229	Double electric 3-way valve AD3E01C (PDxx20/PDxx30)
16	4	403768	Solenoid coil 240/230VAC K12-233 (PDxx10/PDxx15)
17	8	403768	Solenoid coil 240/230VAC K12-233 (PDxx20/PDxx30)
19	1	820407	Control lamp PD2620/5720 (8 knob)
20	1	820393	Control lamp PD2610/5710 (4knob)
21	1	205745	Control lamp bracket PDxx10/PDxx20
25	2	820415	Cable valves PDxx10/PDxx15
26	4	820415	Cable valves PDxx20/PDxx30
30	1	--	Socket for RF receiver

Overview drawing wireless control lamp

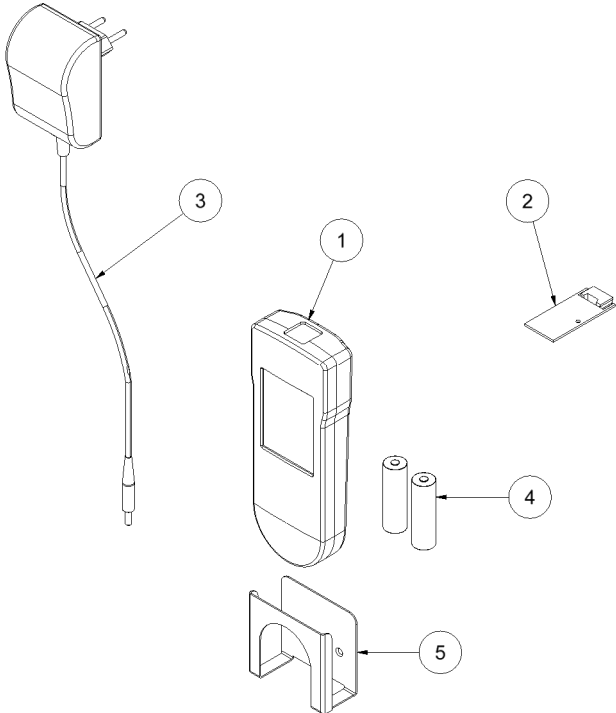

Parts list wireless control lamp

ITEM	QTY	PART NR	DESCRIPTION
1	1	822353	Remote control RF (wireless control lamp)
2	1	822388	RF transceiver assy
3	1	206075	RF battery charger
4	2	205443	Rechargeable battery
5	1	822469	Remote control RF hanging bracket
10		906794	Control lamp set wireless (RF) PD26xx/PD57xx

In case of ordering 822353 or 906794 wireless control lamp, mention the model of the play detector. The software determines the model.

Overview drawing floor module

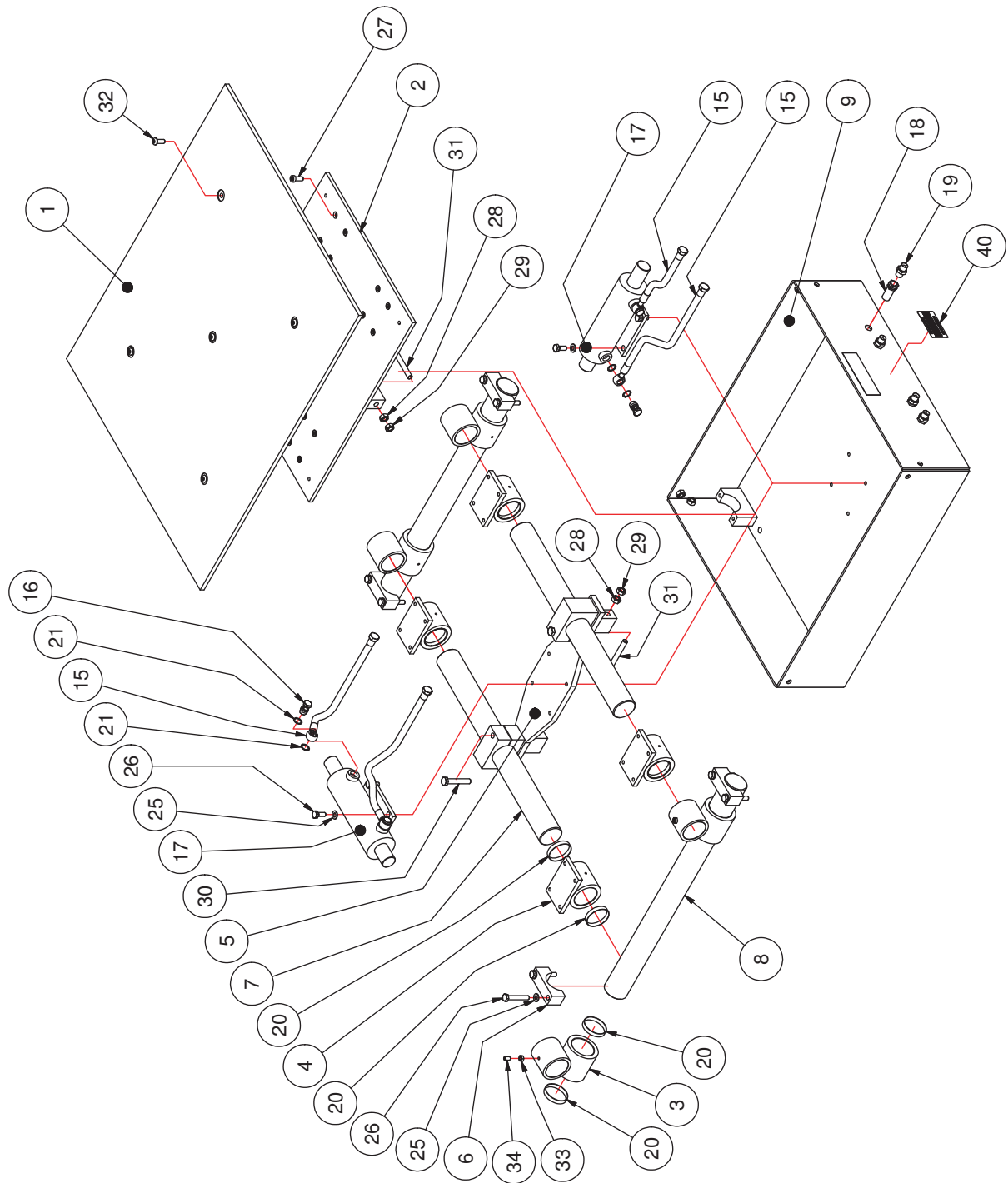

Parts list

ITEM	QTY	PART NR	DESCRIPTION
1	2	403008	Platform top plate
2	2	403016	Control plate
3	8	403059	Inferior sliding insert
4	8	403067	Superior sliding insert
5	2	403113	Cylinder support
6	16	403105	Cover axle
7	4	403148	Short axle
8	4	403156	Long axle
9	2	403164	Machine body
15	8	403024	Hose with banjo
16	8	403040	Bolt for banjo
17	4	403113	Hydraulic cylinder
18	8	403180	Straight connection
19	8	404314	Nipple male/male 3/8"
20	32	403083	Rod seal
21	8	404322	Copper washer 3-8
25	32	100447	Washer DIN 125 - A 10,5
26	16	101257	Din 933 Hex head bolt M10x45
27	32	104345	Din 7984 Hex socket screw low M10x25
28	4	101958	Din 934 - M12 Hex Nut
29	4	102636	Din 985 - M12 Hex lock nut
30	4	102261	Din 933 Hex head bolt M12x70
31	4	104337	Din 7991 Countersunk socket M12x90
32	10	100854	ISO 7380 Hex socket button M10x30
33	4	100404	Din 934 - M8 Hex Nut
34	1	103888	Din 916 M10x12 Hexagon socket set screw
40	1		Sticker part no.

Index

A

address company • 2
adjustments • 43
application program • 49
auto button • 22, 24

B

battery
 level • 20, 24
bearing • 41
boot loader • 49
buttons on the control lamp • 19

C

cable requirements • 29
center plate on start-up • 43
company address • 2
control box • 25
control lamp • 19, 20, 22, 24

D

de-aerate • 39
description play detector • 9
DIP-switch • 43

E

electrical connections • 35
emergency stop • 38

F

fill with oil • 39
floor unit • 18

H

hoisting • 27
hydraulic control unit • 25
hydraulic hoses specification • 29
hydraulic system check • 42
hydraulic system safety • 12
hydraulics installation • 31

I

inspection pit • 28
installation

application program • 49
 electrical • 35
 hydraulics • 31
inspection pit • 28

L

lockout • 13

M

mains switch • 25, 38
maintenance • 41
maintenance schedule • 41

P

phase button • 22, 24
pit dimensions • 28
play detector • 9
power requirements • 29
preparations for installation • 27
pump • 25

R

remote control • See control lamp
reset button • 22, 24

S

safety • 11
safety features • 12
safety hydraulics • 12
sleep mode • 20, 24
software • 49
storage • 27
system check • 39
system overview • 17

T

transport • 27

V

valve block • 25