

RoHS Compliant Product

Description

The S5U2178 series positive, linear regulators feature low quiescent current (45µA typ.) with low dropout voltage, making them ideal for battery applications. Output voltage are set at the factory and trimmed to 1.5% accuracy. These rugged devices have both Thermal Shutdown and Current Fold-back to prevent device failure under the "Worst" of operating conditions. In applications requiring a low noise, regulated supply, place a 1000pF capacitor between Bypass and Ground. The S5U2178 is stable with an output capacitance of 4.7µF or greater.

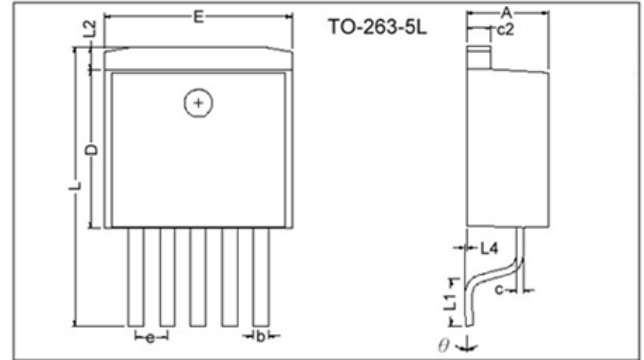

REF.	Millimeter		REF.	Millimeter	
	Min.	Max.		Min.	Max.
A	4.40	4.80	c2	1.25	1.45
b	0.66	0.91	L2	1.27	REF.
L4	0.00	0.30	D	8.6	9.0
c	0.36	0.5	e	1.70	REF.
L1	2.29	2.79	L	14.6	15.8
E	9.80	10.4	θ	0°	8°

Features

- * Low Temperature Coefficient
- * Over-Temperature Shutdown
- * Highly Accurate ± 1.5%
- * Very Low Dropout Voltage
- * Noise Reduction Bypass Capacitor
- * Short Circuit Current Fold-back
- * Guaranteed 1.5 A output
- * Current Limiting
- * Power-Saving Shutdown Mode

Applications

- * PC Peripherals
- * Wireless Devices
- * Portable Electronics
- * Battery Powered Widgets
- * Instrumentation

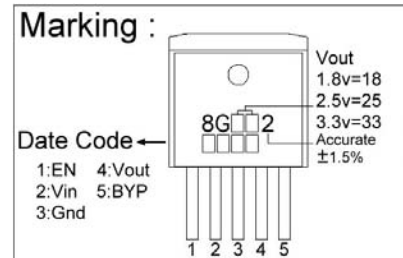

Typical Application Circuit

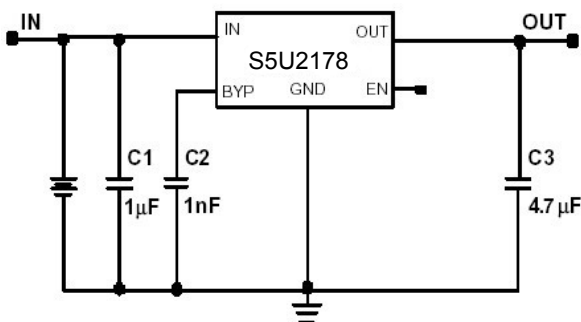

Functional Block Diagram

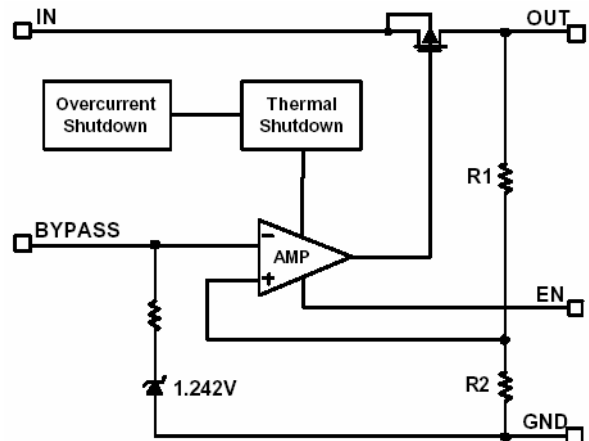

Absolute Maximum Ratings

Parameter	Symbol	Ratings	Unit
Input Max Voltage	V _{IN}	8	V
Output Current	I _{OUT}	P _D /(V _{IN} -V _O)	A
Output Voltage	V _{OUT}	1.5~5.0	V
Operating Ambient Temperature	T _{opr}	-40 ~ +85	°C
Junction Temperature	T _j	-40 ~ +125	°C
Maximum Junction Temperature	T _{j Max}	150	°C
Thermal Resistance	θ _{jc}	5	°C/W
Internal Power Dissipation(ΔT=100°C)	PD	3000	mW
EDS Classification		B	

Electrical Characteristics V_{IN}=V_{OUT}(T)+2V, V_{EN}=V_{IN}, T_A=25°C unless otherwise noted

Parameter	Symbol	Condition	Min	TYP	Max	Unit	
Output Voltage	V _{OUT} (E) (Note1)	V _{EN} =V _{EHmin} , I _O =1mA	-1.5%	V _{OUT} (T) (Note2)	1.5%	V	
Output Current	I _O	V _{OUT} >1.2V	1.5	-	-	A	
Current Limit	I _{LIM}	V _{OUT} >1.2V	1.5	2.0	-	A	
Load Regulation	REG _{LOAD}	I _O =1mA to 1.5A	-1	0.2	1	%	
Dropout Voltage	V _{DROPOUT}	I _O =1.5A V _O =V _{OUT} (E)-2%	1.5V<V _{OUT} (T)≤2.0V	-	-	1300	mV
		2.0V<V _{OUT} (T)≤2.8V	-	-	800		
		2.8V<V _{OUT} (T)	-	-	600		
Quiescent Current	I _Q	I _O =0mA	-	45	70	μA	
Ground Pin Current	I _{GND}	I _O =1mA~1.5A	-	45	-	μA	
Line Regulation	REG _{LINE}	I _O =1mA V _{IN} =V _{OUT} V _{OUT} (T)+2	V _{OUT} (T)<2.0V	-0.15	-	0.15	%
			2.0V≤V _{OUT} (T)<4.0V	-0.1	0.02	0.1	
			4.0V≤V _{OUT} (T)	-0.4	-	0.4	
Input Voltage	V _{IN}		Note3	-	7	V	
Over Temperature Shutdown	OTS		-	150	-	°C	
Over Temperature Hysterisis	OTH		-	30	-	°C	
Output Voltage Temperature Coefficient	TC		-	30	-	ppm/°C	
Short Circuit Current	I _{sc}	V _{OUT} <0.4V	-	750	-	mA	
Power Supply Rejection	PSRR	I _O =100mA C _O =4.7μF ceramic	f=1kHz	-	50	-	dB
			f=10kHz	-	20	-	
Power Supply Rejection	PSRR	I _O =100mA C _O =4.7μF ceramic C _{BYP} =0.01μF	f=1kHz	-	75	-	dB
			f=10kHz	-	55	-	
Output Voltage Noise	e _N	f=10Hz~100kHz I _O =10mA, C _{BYP} =0μF	Co=4.7μF	-	30	-	μVrms
Output Voltage Noise	e _N	f=10Hz~100kHz I _O =10mA, C _{BYP} =0.01μF	Co=4.7μF	-	30	-	μVrms
EN Input Threshold	V _{EH}		2.0	-	V _{IN}	V	
	V _{EL}		0	-	0.4	V	
EN Input Bias Current	I _{EH}	V _{IN} =7V	-	-	0.1	μA	
	I _{EL}	V _{EN} =0V, V _{IN} =7V	-	-	0.5	μA	
Shutdown Supply Current	I _{SD}	V _{IN} =5V, V _{OUT} =0V, V _{EN} =0V	-	0.5	2	μA	

Note 1: $V_{OUT(E)}$ = Effective Output Voltage (i.e. the output voltage when " $V_{OUT(T)} + 2.0V$ " is provided at the VIN pin while maintaining a certain I_{OUT} value).

2: $V_{OUT(T)}$ = Specified Output Voltage

3: $V_{IN(MIN)} = V_{OUT} + V_{DROPOUT}$

Ordering Information(contd.)

Part Number	Marking	Output Voltage	Part Number	Marking	Output Voltage
S5U2178-15	8G152 XXXX	1.5V	S5U2178-18	8G182 XXXX	1.8V
S5U2178-25	8G252 XXXX	2.5V	S5U2178-33	8G332 XXXX	3.3V
S5U2178-47	8G472 XXXX	4.7V	S5U2178-50	8G502 XXXX	5.0V

Detailed Description

The S5U 2178 of COMS regulators contain a PMOS pass transistor, voltage reference, error amplifier, over-current protection and thermal shutdown. The P-channel pass transistor receives data from the error amplifier, over-current shutdown, and thermal protection circuits. During normal operation, the error amplifier compares the output voltage to a precision reference. Over-current and Thermal shutdown circuits become active when the junction temperature exceeds $140^{\circ}C$, or the current exceeds 2.2A. During thermal shutdown, the output voltage remains low. Normal operation is restored when the junction temperature drops below $120^{\circ}C$. The S5U 2178 behaves like a current source when the load reaches 2.2A. However, if the load impedance drops below 0.3Ω , the current drops back to 600mA to prevent excessive power dissipation. Normal operation is restored when the load resistance exceeds of 0.75Ω .

External Capacitors

The S5U 2178 is stable with an output capacitance to ground of 4.7uF or greater. Ceramic capacitors have the lowest ESR, and will offer the best AC performance. Conversely, Aluminum Electrolytic capacitors exhibit the highest ESR, resulting in the poorest AC response. Unfortunately, large value ceramic capacitors are comparatively expensive. One option is to parallel a 0.1uF ceramic capacitor with a 10uF Aluminum Electrolytic. The benefit is low ESR, high capacitance, and low overall cost. A second capacitor is recommended between the input and ground to stabilize V_{IN} . The input capacitor should be at least 0.1uF to have a beneficial effect. A third capacitor can be connected between the BY-PASS pin and GND. This capacitor can be a low cost Polyester Film variety between the value of 0.001~0.01uF. A large capacitor improves the AC ripple rejection, but also makes the output come up slowly. This "Soft" turn-on is desirable in some applications to limit turn-on surges. All capacitors should be placed in closed proximity to the pins. A "Quiet" ground termination is desirable. This can be achieved with a "Star" connection.

Enable

When EN pin is pulled low, the PMOS pass transistor shuts off, and all internal circuits are powered down. In this state, the quiescent current is less than 1uA. This pin behaves much like an electronic switch. 100K Ω resistor is necessary between V_{EN} source and EN pin when V_{EN} is high than V_{IN} . (Note: There is no internal pull-up for EN pin. It can not be floating.)

Characteristics Curve

